

DATA TRANSLATION

UM-21336-U

***DT9816 Series
User's Manual***

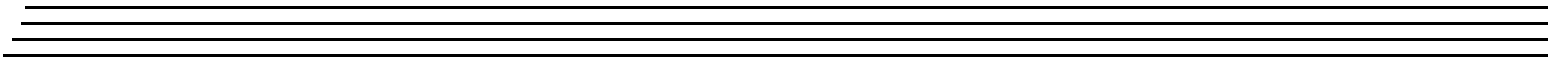
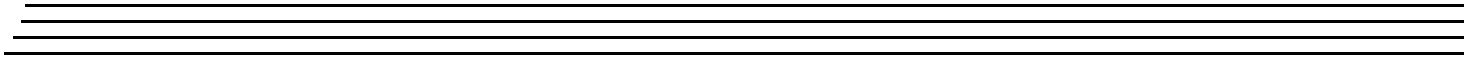
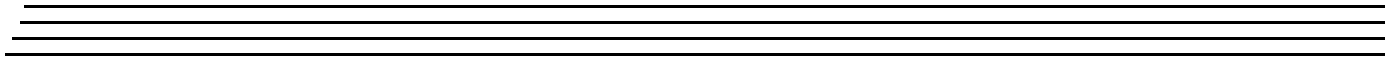

**Twentieth Edition
January, 2014**

Copyright © 2014 by Data Translation, Inc.
All rights reserved.

Information furnished by Data Translation, Inc. is believed to be accurate and reliable; however, no responsibility is assumed by Data Translation, Inc. for its use; nor for any infringements of patents or other rights of third parties which may result from its use. No license is granted by implication or otherwise under any patent rights of Data Translation, Inc.

Use, duplication, or disclosure by the United States Government is subject to restrictions as set forth in subparagraph (c)(1)(ii) of the Rights in Technical Data and Computer software clause at 48 C.F.R. 252.227-7013, or in subparagraph (c)(2) of the Commercial Computer Software - Registered Rights clause at 48 C.F.R., 52-227-19 as applicable. Data Translation, Inc., 100 Locke Drive, Marlboro, MA 01752.

Data Translation, Inc.
100 Locke Drive
Marlboro, MA 01752-1192
(508) 481-3700
www.datatranslation.com
Fax: (508) 481-8620
E-mail: info@datx.com

Data Translation® is a registered trademark of Data Translation, Inc. DT-Open Layers™, DT-Open Layers for .NET Class Library™, DataAcq SDK™, OMNI CD™, LV-Link™, and QuickDAQ™ are trademarks of Data Translation, Inc.

All other brand and product names are trademarks or registered trademarks of their respective companies.

Radio and Television Interference

This equipment has been tested and found to comply with CISPR EN55022 Class A and EN61000-6-1 requirements and also with the limits for a Class A digital device, pursuant to Part 15 of the FCC Rules. These limits are designed to provide reasonable protection against harmful interference when the equipment is operated in a commercial environment. This equipment generates, uses, and can radiate radio frequency energy and, if not installed and used in accordance with the instruction manual, may cause harmful interference to radio communications. Operation of this equipment in a residential area is likely to cause harmful interference, in which case the user will be required to correct the interference at his own expense.

Changes or modifications to this equipment not expressly approved by Data Translation could void your authority to operate the equipment under Part 15 of the FCC Rules.

Note: This product was verified to meet FCC requirements under test conditions that included use of shielded cables and connectors between system components. It is important that you use shielded cables and connectors to reduce the possibility of causing interference to radio, television, and other electronic devices.

Canadian Department of Communications Statement

This digital apparatus does not exceed the Class A limits for radio noise emissions from digital apparatus set out in the Radio Interference Regulations of the Canadian Department of Communications.

Le présent appareil numérique n'émet pas de bruits radioélectriques dépassant les limites applicables aux appareils numériques de la class A prescrites dans le Règlement sur le brouillage radioélectrique édicté par le Ministère des Communications du Canada.

Table of Contents

About this Manual	9
Intended Audience	9
How this Manual is Organized	9
Conventions Used in this Manual	10
Related Information	10
Where To Get Help	11
Chapter 1: Overview	13
Key Hardware Features	14
Supported Software	16
Getting Started Procedure	19
Part 1: Getting Started	21
Chapter 2: Setting Up and Installing the Module	23
Unpacking	25
System Requirements	26
Attaching Modules to the Computer	27
Connecting Directly to the USB Ports	27
Connecting to an Expansion Hub	28
Changing the Name of a Module (Optional)	30
Chapter 3: Wiring Signals to the Module	31
Preparing to Wire Signals	33
Wiring Recommendations	33
Wiring Signals to the DT9816, DT9816-A, or DT9816-S Module	33
Wiring Signals to the DT9816-OEM Module	36
Connecting Single-Ended Analog Input Signals	38
Connecting Digital Input Signals	39
Connecting Digital Output Signals	40
Connecting Counter/Timer Signals	41
Connecting Signals for Event Counting	41
Connecting Signals for Frequency Measurement	42
Connecting Signals for Rate Generation	43
Chapter 4: Verifying the Operation of a Module	45
Running the Quick DataAcq Application	47
Testing Single-Value Analog Input	48
Testing Continuous Analog Input	49
Testing Single-Value Digital Input	50

Testing Single-Value Digital Output	51
Testing Frequency Measurement	52
Testing Pulse Output	53
Part 2: Using Your Module	55
Chapter 5: Principles of Operation	57
Analog Input Features	59
Input Resolution	59
Analog Input Channels	59
Specifying a Single Analog Input Channel	59
Specifying One or More Analog Input Channels	60
Input Ranges and Gains	60
Input Sample Clock Sources	60
Internal A/D Sample Clock	60
External A/D Sample Clock	61
Analog Input Conversion Modes	61
Single-Value Operations	62
Continuous Scan Mode	62
Input Triggers	63
Data Format and Transfer	63
Error Conditions	63
Digital I/O Features	64
Digital I/O Lines	64
Resolution	64
Operation Modes	64
Counter/Timer Features	65
C/T Channel	65
C/T Clock Sources	66
Gate Types	66
Pulse Duty Cycles	66
Counter/Timer Operation Modes	67
Event Counting	67
Frequency Measurement	67
Rate Generation	68
Chapter 6: Supported Device Driver Capabilities	69
Data Flow and Operation Options	71
Buffering	72
Triggered Scan Mode	72
Data Encoding	72
Channels	73

Gain	73
Ranges	74
Resolution	74
Current and Resistance Support	74
Thermocouple, RTD, and Thermistor Support	75
IEPE Support.....	76
Bridge and Strain Gage Support	76
Start Triggers.....	77
Reference Triggers	77
Clocks.....	78
Counter/Timers	79
Tachometers.....	80
Chapter 7: Troubleshooting	81
General Checklist	82
Technical Support	84
If Your Module Needs Factory Service	85
Appendix A: Specifications	87
Analog Input Specifications	88
Digital I/O Specifications	90
Counter/Timer Specifications	91
External Trigger Specifications.....	92
External Clock Specifications	93
Power, Physical, and Environmental Specifications	94
Regulatory Specifications	95
Mating Connector Specifications.....	96
Appendix B: Screw Terminal and Connector Pin Assignments and LED Status Indicators	97
Screw Terminal Assignments	98
DT9816-OEM Connector Pin Assignments	99
LED Status Indicators	101
Index	103

About this Manual

The first part of this manual describes how to install and set up your DT9816, DT9816-A, DT9816-S, or DT9816-OEM module and software, and verify that your module is working properly.

The second part of this manual describes the features of the DT9816, DT9816-A, DT9816-S, and DT9816-OEM modules and device driver, and how to program your module using the DT-Open Layers for .NET Class Library™ software. Troubleshooting information is also provided.

Note: For information on checking system requirements, installing the software, and viewing the documentation, refer to the README file on the OMNI CD.

For more information on the class library, refer to the *DT-Open Layers for .NET Class Library User's Manual*. If you are using the DataAcq SDK or a software application to program your device, refer to the documentation for that software for more information.

If the information in this manual applies to all versions of the DT9816 module, this manual uses the product name "DT9816 Series module." If the information applies to a specific module, this manual uses the specific product name.

Intended Audience

This document is intended for engineers, scientists, technicians, or others responsible for using and/or programming the DT9816 Series module for analog input, digital I/O, or counter/timer operations in the Microsoft® Windows® XP, Windows Vista®, Windows 7, or Windows 8 operating system. It is assumed that you have some familiarity with data acquisition principles and that you understand your application.

How this Manual is Organized

This manual is organized as follows:

- [Chapter 1, "Overview,"](#) describes the major features of the DT9816 Series modules, as well as the supported software and accessories for the module.
- [Chapter 2, "Setting Up and Installing the Module,"](#) describes how to install the module and how to configure the device driver.
- [Chapter 3, "Wiring Signals to the Module,"](#) describes how to wire signals to the module.
- [Chapter 4, "Verifying the Operation of a Module,"](#) describes how to verify the operation of the module with the Quick DataAcq application.
- [Chapter 5, "Principles of Operation,"](#) describes all of the features of the DT9816 Series modules and how to use them in your application.

- [Chapter 6, “Supported Device Driver Capabilities,”](#) lists the supported subsystems and the associated capabilities accessible using the device driver for the DT9816 Series modules.
- [Chapter 7, “Troubleshooting,”](#) provides information that you can use to resolve problems with a DT9816 Series module should they occur.
- [Appendix A, “Specifications,”](#) lists the specifications of the DT9816 Series module.
- [Appendix B, “Screw Terminal and Connector Pin Assignments and LED Status Indicators,”](#) shows the screw terminal and connector pin assignments for the DT9816 Series modules.
- An index completes this manual.

Conventions Used in this Manual

The following conventions are used in this manual:

- Notes provide useful information or information that requires special emphasis, cautions provide information to help you avoid losing data or damaging your equipment, and warnings provide information to help you avoid catastrophic damage to yourself or your equipment.
- Items that you select or type are shown in **bold**.

Related Information

Refer to the following documents for more information on using the DT9816 Series modules:

- *Benefits of the Universal Serial Bus for Data Acquisition*. This white paper describes why USB is an attractive alternative for data acquisition. It is available on the Data Translation web site (www.datatranslation.com).
- *QuickDAQ User’s Manual (UM-24774)*. This manual describes how to create a QuickDAQ application to acquire and analyze data from DT-Open Layers data acquisition devices.
- *DT-Open Layers for .NET User’s Manual (UM-22161)*. For programmers who are developing their own application programs using Visual C# or Visual Basic .NET, this manual describes how to use the DT-Open Layers for .NET Class Library to access the capabilities or Data Translation data acquisition devices.
- *DataAcq SDK User’s Manual (UM-18326)*. For programmers who are developing their own application programs using the Microsoft C compiler, this manual describes how to use the DT-Open Layers DataAcq SDK™ to access the capabilities of Data Translation data acquisition devices.
- *DAQ Adaptor for MATLAB (UM-22024)*. This document describes how to use Data Translation’s DAQ Adaptor to provide an interface between the MATLAB Data Acquisition subsystem from The MathWorks and Data Translation’s DT-Open Layers architecture.
- *LV-Link Online Help*. This help file describes how to use LV-Link™ with the LabVIEW™ graphical programming language to access the capabilities of Data Translation data acquisition devices.

- Microsoft Windows XP, Windows Vista, Windows 7, or Windows 8 documentation.
- USB web site (<http://www.usb.org>).

Where To Get Help

Should you run into problems installing or using a DT9816 Series module, the Data Translation Technical Support Department is available to provide technical assistance. Refer to [Chapter 7](#) for more information. If you are outside the United States or Canada, call your local distributor, whose number is listed on Data Translation's web site (www.datatranslation.com).



Overview

Key Hardware Features	14
Supported Software	16
Getting Started Procedure	19

Key Hardware Features

The DT9816 Series is part of the ECONseries of economy, multifunction mini-instruments. The following modules comprise the DT9816 Series: the DT9816 (shown in [Figure 1](#)), DT9816-A, DT9816-S, and DT9816-OEM.



Figure 1: DT9816 Module

Table 1 summarizes the key features of each module.

Table 1: Key Features of the DT9816 Module

Module	Analog Inputs	Analog Input Resolution	I/O Range	Analog Input Sample Rate	Digital I/O	C/T
DT9816 and DT9816-OEM ^a	6 SE	16-bit	± 10 V or ± 5 V	50 kS/s per channel	8 in/ 8 out	1
DT9816-A	6 SE	16-bit	± 10 V or ± 5 V	153.846 kS/s per channel	8 in/ 8 out	1
DT9816-S	6 SE	16-bit	± 10 V or ± 5 V	750 kS/s per channel	8 in/ 8 out	1

a. The DT9816-OEM is an uncased, board-level module provided for OEM customers. Rather than provide screw terminals, this module provides 2, 20-pin connectors for connecting I/O signals.

The key features are listed as follows:

- Six, independent, successive-approximation A/D converters with track-and-hold circuitry. Each converter uses a common clock and trigger for simultaneous sampling of all six analog input signals at up to 50 kHz per channel (DT9816 and DT9816-OEM), 153.846 kHz per channel (DT9816-A), or 750 kHz per channel (DT9816-S).
- Analog input subsystem provides 16-bit resolution and gains of 1 and 2 for effective full-scale input signal ranges of ± 10 V and ± 5 V.
- 8 digital inputs and 8 digital outputs
- 1, 16-bit counter/timer allows you to perform event counting, frequency measurement, and continuous pulse output (rate generation) operations
- Standard USB connector
- Shielded, rugged enclosure for noise immunity
- Low power device – draws less than 100 mA

Supported Software

The following software is available for use with the DT9816 Series module, and is provided on the OMNI CD:

- **Device Driver** – The DT9816 Device Driver allows you to use a DT9816 Series module with any of the supported software packages or utilities. Refer to [page 30](#) for more information on configuring the device driver.
- **Quick DataAcq application** – The Quick DataAcq application provides a quick way to get up and running using a DT9816 Series module. Using this application, you can verify key features of the module, display data on the screen, and save data to disk. Refer to [Chapter 4](#) for more information on using the Quick DataAcq application.
- **QuickDAQ Base Version** – The base version of QuickDAQ is free-of-charge and allows you to acquire and analyze data from all Data Translation USB and Ethernet devices, except the DT9841 Series, DT9817, DT9835, and DT9853/54. Using the base version of QuickDAQ, you can perform the following functions:
 - Discover and select your devices.
 - Configure all input channel settings for the attached sensors.
 - Load/save multiple hardware configurations.
 - Generate output stimuli (fixed waveforms, swept sine waves, or noise signals).
 - On each supported data acquisition device, acquire data from all channels supported in the input channel list.
 - Choose to acquire data continuously or for a specified duration.
 - Choose software or triggered acquisition.
 - Log acquired data to disk in an .hpf file.
 - Display acquired data during acquisition in either a digital display using the Channel Display window or as a waveform in the Channel Plot window.
 - Choose linear or logarithmic scaling for the horizontal and vertical axes.
 - View statistics about the acquired data, including the minimum, maximum, delta, and mean values and the standard deviation in the Statistics window.
 - Export time data to a .csv or .txt file; you can open the recorded data in Microsoft Excel® for further analysis.
 - Read a previously recorded .hpf data file.
 - Customize many aspects of the acquisition, display, and recording functions to suit your needs, including the acquisition duration, sampling frequency, trigger settings, filter type, and temperature units to use.
- **QuickDAQ FFT Analysis Option** – When enabled with a purchased license key, the QuickDAQ FFT Analysis option includes all the features of the QuickDAQ Base version plus basic FFT analysis features, including the following:
 - The ability to switch between the Data Logger time-based interface and the FFT Analyzer block/average-based interface.

- Supports software, freerun, or triggered acquisition with accept and reject controls for impact testing applications.
- Allows you to perform single-channel FFT (Fast Fourier Transform) operations, including AutoSpectrum, Spectrum, and Power Spectral Density, on the acquired analog input data. You can configure a number of parameters for the FFT, including the FFT size, windowing type, averaging type, integration type, and so on.
- Allows you to display frequency-domain data as amplitude or phase.
- Supports dB or linear scaling with RMS (root mean squared), peak, and peak-to-peak scaling options
- Supports linear or exponential averaging with RMS, vector, and peak hold averaging options.
- Supports windowed time channels.
- Supports the following response window types: Hanning, Hamming, Bartlett, Blackman, Blackman Harris, and Flat top.
- Supports the ability to lock the waveform output to the analysis frame time.
- Allows you to configure and view dynamic performance statistics, including the input below full-scale (IBF), total harmonic distortion (THD), spurious free dynamic range (SFDR), signal-to-noise and distortion ratio (SINAD), signal-to-noise ratio (SNR), and the effective number of bits (ENOB), for selected time-domain channels in the Statistics window.
- Supports digital IIR (infinite impulse response) filters
- **QuickDAQ Advanced FFT Analysis Option** – When enabled with a purchased software license, the QuickDAQ Advanced FFT Analysis option includes all the features of the QuickDAQ Base version with the FFT Analysis option plus advanced FFT analysis features, including the following:
 - Allows you to designate a channel as a Reference or Response channel.
 - Allows you to perform two-channel FFT analysis functions, including Frequency Response Functions (Inertance, Mobility, Compliance, Apparent Mass, Impedance, Dynamic Stiffness, or custom FRF) with H1, H2, or H3 estimator types, Cross-Spectrum, Cross Power Spectral Density, Coherence, and Coherent Output Power.
 - Supports the Exponential response window type.
 - Supports the following reference window types: Hanning, Hamming, Bartlett, Blackman, Blackman Harris, FlatTop, Exponential, Force, and Cosine Taper windows.
 - Supports real, imaginary, and Nyquist display functions.
 - Allows you to save data in the .uff file format.
- **DT-Open Layers for .NET Class Library** – Use this class library if you want to use Visual C# or Visual Basic for .NET to develop your own application software for a DT9816 Series module using Visual Studio 2003-2012; the class library complies with the DT-Open Layers standard.

- **DataAcq SDK** – Use the Data Acq SDK if you want to use Visual Studio 6.0 and Microsoft C or C++ to develop your own application software for a DT9816 Series module using Windows XP, Windows Vista, Windows 7, or Windows 8; the DataAcq SDK complies with the DT-Open Layers standard.
- **DAQ Adaptor for MATLAB** – Data Translation’s DAQ Adaptor provides an interface between the MATLAB Data Acquisition (DAQ) subsystem from The MathWorks and Data Translation’s DT-Open Layers architecture.
- **LV-Link** – An evaluation version of LV-Link is provided on the OMNI CD. Use this software package if you want to use the LabVIEW graphical programming language to access the capabilities of a DT9816 Series module.

Getting Started Procedure

The flow diagram shown in [Figure 2](#) illustrates the steps needed to get started using a DT9816 Series module. This diagram is repeated in each chapter; the shaded area in the diagram shows you where you are in the getting started procedure.

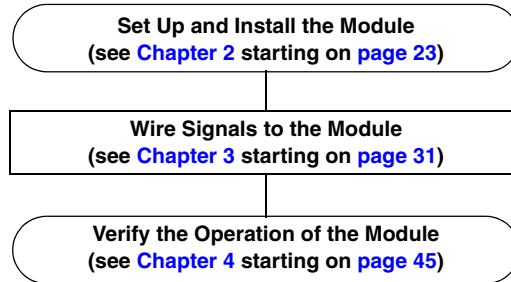

Figure 2: Getting Started Flow Diagram

Part 1: Getting Started



Setting Up and Installing the Module

Unpacking	25
System Requirements	26
Attaching Modules to the Computer	27
Changing the Name of a Module (Optional)	30

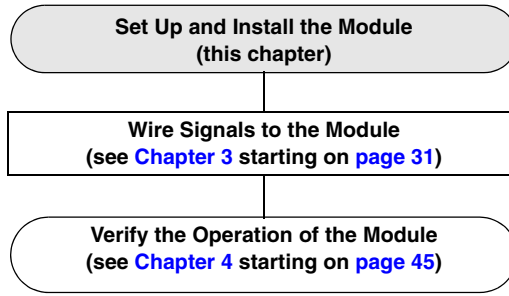

Unpacking

Open the shipping box and verify that the following items are present:

- DT9816, DT9816-A, DT9816-S, or DT9816-OEM module
- OMNI CD
- USB cable (not provided with the DT9816-OEM module)

If an item is missing or damaged, contact Data Translation. If you are in the United States, call the Customer Service Department at (508) 481-3700, ext. 1323. An application engineer will guide you through the appropriate steps for replacing missing or damaged items. If you are located outside the United States, call your local distributor (see Data Translation's web site (www.datatranslation.com) for contact information).

Note: DT9816 Series modules are factory-calibrated and require no further adjustment.

System Requirements

For reliable operation, ensure that your computer meets the following system requirements:

- Processor: Pentium 4/M or equivalent
- RAM: 1 GB
- Screen Resolution: 1024 x 768 pixels
- Operating System: Windows 8, Windows 7, Windows Vista (32- and 64-bit), or Windows XP SP3 (32-bit)
- Disk Space: 4 GB

Attaching Modules to the Computer

This section describes how to attach a DT9816 Series module to the host computer.

Note: The DT9816-OEM module contains a 5-pin USB header instead of a standard USB connector (see [page 100](#) for the pin assignments of this header). To connect to the DT9816-OEM module, you need to purchase the Bulgin USB cable (part#14193). This cable has a 5-pin header on one end for connecting to the module and a standard USB connector on the other end for connecting to the host computer.

Most computers have several USB ports that allow direct connection to USB devices. If your application requires more DT9816 Series modules than you have USB ports for, you can expand the number of USB devices attached to a single USB port by using expansion hubs. For more information, refer to [page 28](#).

You can unplug a module, and then plug it in again, if you wish, without causing damage. This process is called hot-swapping. Your application may take a few seconds to recognize a module once it is plugged back in.

Connecting Directly to the USB Ports

To connect a DT9816 Series module directly to the USB port of your computer, do the following:

1. Attach one end of the USB cable to the USB port on the module.
2. Attach the other end of the USB cable to one of the USB ports on the host computer, as shown in [Figure 3](#).

The operating system automatically detects the USB module and starts the Found New Hardware wizard.

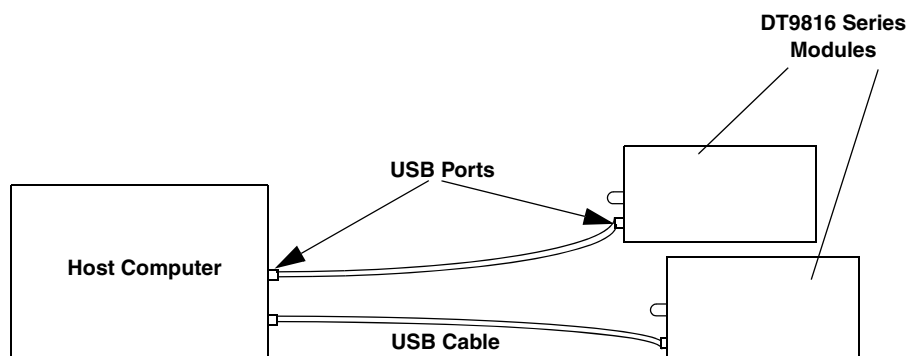

Figure 3: Attaching the Module to the Host Computer

3. For Windows Vista:

- a. Click **Locate and install driver software (recommended)**.
The popup message "Windows needs your permission to continue" appears.
- b. Click **Continue**.
The Windows Security dialog box appears.
- c. Click **Install this driver software anyway**.
The LED on the module turns green.

For Windows XP:

- a. Click **Next** and/or **Finish** as required in the wizard.
Once the firmware is loaded, the wizard restarts to initiate the firmware to accept commands.
- b. Click **Next** and/or **Finish** again.
The LED on the module turns green.

Note: Windows 7 and Windows 8 find the device automatically.

4. Repeat these steps to attach another DT9816 Series module to the host computer, if desired.

Connecting to an Expansion Hub

Expansion hubs are powered by their own external power supply. The practical number of DT9816 Series modules that you can connect to a single USB port depends on the throughput you want to achieve.

To connect multiple DT9816 Series modules to an expansion hub, do the following:

1. Attach one end of the USB cable to the module and the other end of the USB cable to an expansion hub.
2. Connect the power supply for the expansion hub to an external power supply.
3. Connect the expansion hub to the USB port on the host computer using another USB cable.
The operating system automatically detects the USB module and starts the Found New Hardware wizard.

4. For Windows Vista:

- a. Click **Locate and install driver software (recommended)**.
The popup message "Windows needs your permission to continue" appears.
- b. Click **Continue**.
The Windows Security dialog box appears.
- c. Click **Install this driver software anyway**.
The LED on the module turns green.

For Windows XP:

- a. Click **Next** and/or **Finish** as required in the wizard.
Once the firmware is loaded, the wizard restarts to initiate the firmware to accept commands.

- b. Click **Next** and/or **Finish** again.
The LED on the module turns green.

Note: Windows 7 and Windows 8 find the device automatically.

5. Repeat these steps until you have attached the number of expansion hubs and modules that you require. Refer to [Figure 4](#).
The operating system automatically detects the USB devices as they are installed.

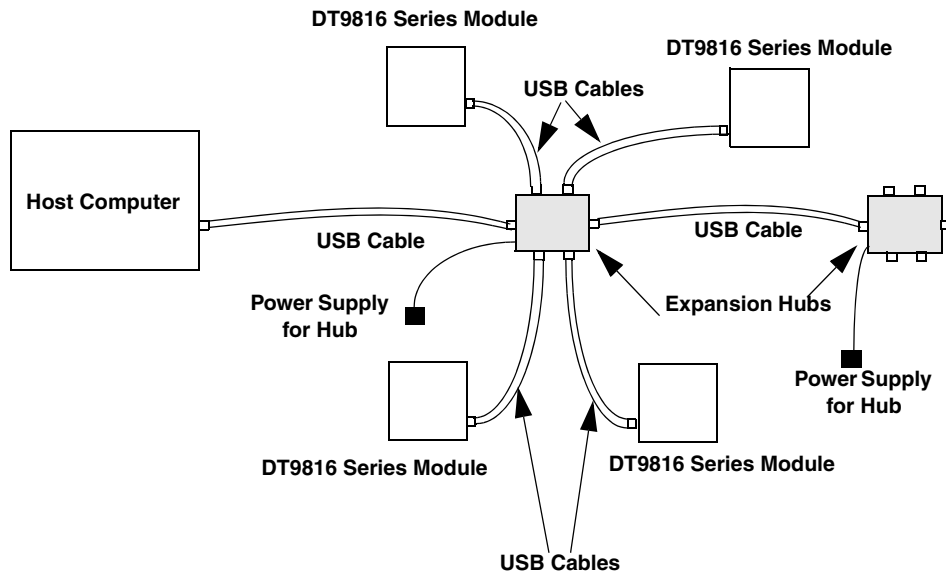

Figure 4: Attaching Multiple DT9816 Series Modules Using Expansion Hubs

Changing the Name of a Module (Optional)

Note: In Windows 7, Windows 8, and Vista, you must have administrator privileges to run the Open Layers Control Panel. When you double-click the Open Layers Control Panel icon, you may see the Program Compatibility Assistant. If you do, select **Open the control panel using recommended settings**. You may also see a Windows message asking you if you want to run the Open Layers Control Panel as a "legacy CPL elevated." If you get this message, click **Yes**.

If you do not get this message and have trouble making changes in the Open Layers Control Panel, right click the DTOLCPL.CPL file and select **Run as administrator**. By default, this file is installed in the following location:

Windows 7, Windows 8, and Vista (32-bit)

C:\Windows\System32\Dtolcpl.cpl

Windows 7, Windows 8, and Vista (64-bit)

C:\Windows\SysWOW64\Dtolcpl.cpl

To change the name of a DT9816 Series module, configure the device driver as follows:

1. From the Windows Start menu, select **Settings | Control Panel**.
2. From the Control Panel, double-click **Open Layers Control Panel**.
The Data Acquisition Control Panel dialog box appears.
3. If you want to rename the module, click the DT9816 Series module that you want to rename, and then click **Edit Name**.
4. Enter a new name for the module, and then click **OK**. The name is used to identify the module in all subsequent applications.
5. When you are finished configuring the module, click **Close**.
6. Repeat steps 3 to 5 for the other modules that you want to configure.
7. Close the Data Acquisition Control Panel dialog box.

Continue with the instructions on wiring in [Chapter 3](#) starting on [page 31](#).



Wiring Signals to the Module

Preparing to Wire Signals	33
Connecting Single-Ended Analog Input Signals	38
Connecting Digital Input Signals	39
Connecting Digital Output Signals	40
Connecting Counter/Timer Signals	41

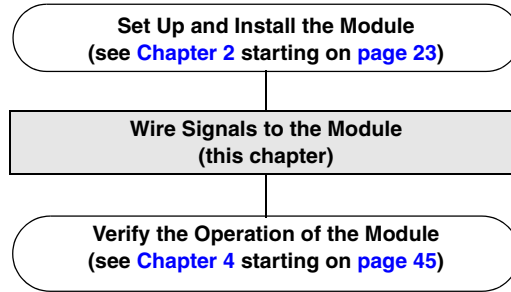

Preparing to Wire Signals

This section provides recommendations and information about wiring signals to a DT9816 Series module.

Wiring Recommendations

Keep the following recommendations in mind when wiring signals to a DT9816 Series module:

- Follow standard ESD procedures when wiring signals to the module.
- Use individually shielded twisted-pair wire (size 16 to 26 AWG) in highly noisy electrical environments.
- Separate power and signal lines by using physically different wiring paths or conduits.
- To avoid noise, do not locate the box and cabling next to sources that produce high electromagnetic fields, such as large electric motors, power lines, solenoids, and electric arcs, unless the signals are enclosed in a mumetal shield.
- Prevent electrostatic discharge to the I/O while the box is operational.
- Connect all unused analog input channels to analog ground.

Wiring Signals to the DT9816, DT9816-A, or DT9816-S Module

To wire signals to a DT9816, DT9816-A, or DT9816-S module, use the screw terminals on the module, shown in [Figure 5](#).



Figure 5: Screw Terminals on the DT9816, DT9816-A, and DT9816-S Modules

Table 2 lists the screw terminal assignments.

Table 2: Screw Terminal Assignments for the DT9816, DT9816-A, and DT9816-S Modules

Terminal	Signal	Terminal	Signal
20	USB +5 V Out	40	Ext Trigger
19	Ground	39	Ext Clock
18	Counter 0 In	38	Ground
17	Counter 0 Out	37	Digital Output 7
16	Counter 0 Gate	36	Digital Output 6
15	Ground	35	Digital Output 5
14	Reserved	34	Digital Output 4
13	Reserved	33	Digital Output 3
12	Reserved	32	Digital Output 2
11	Reserved	31	Digital Output 1
10	2.5 V Reference	30	Digital Output 0
9	Analog Ground	29	Ground
8	Reserved	28	Digital Input 7
7	Reserved	27	Digital Input 6
6	Analog Input CH5	26	Digital Input 5
5	Analog Input CH4	25	Digital Input 4
4	Analog Input CH3	24	Digital Input 3
3	Analog Input CH2	23	Digital Input 2
2	Analog Input CH1	22	Digital Input 1
1	Analog Input CH0	21	Digital Input 0

Wiring Signals to the DT9816-OEM Module

The DT9816-OEM module provides two 20-pin connectors (the Analog Input connector and Digital I/O connector) for wiring signals. [Figure 6](#) shows the location of these two connectors.

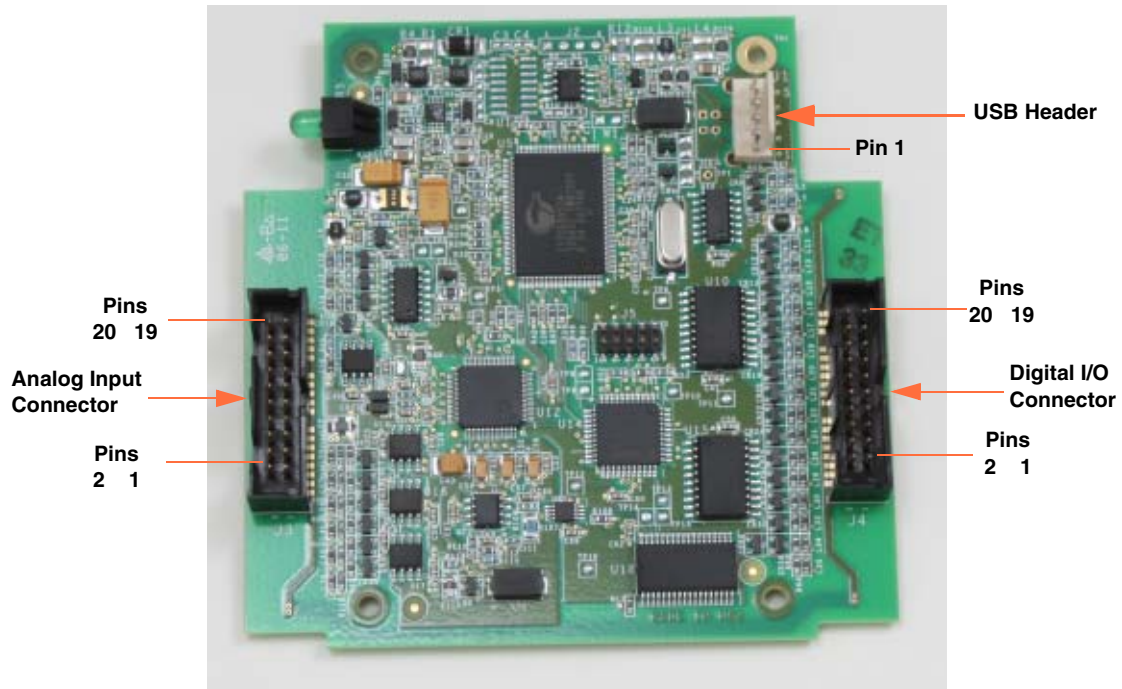

Figure 6: Layout of the DT9816-OEM Module

[Table 3](#) lists the pin assignments for the Analog Input connector on the DT9816-OEM module.

Table 3: Analog Input Connector Pin Assignments on the DT9816-OEM Module

Pin	Signal	Pin	Signal
20	USB +5 V Out	19	Ground
18	Counter 0 In	17	Counter 0 Out
16	Counter 0 Gate	15	Ground
14	Reserved	13	Reserved
12	Reserved	11	Reserved
10	2.5 V Reference	9	Analog Ground
8	Reserved	7	Reserved
6	Analog Input CH5	5	Analog Input CH4
4	Analog Input CH3	3	Analog Input CH2
2	Analog Input CH1	1	Analog Input CH0

[Table 4](#) lists the pin assignments for the Digital I/O connector on the DT9816-OEM module.

Table 4: Digital I/O Connector Pin Assignments on the DT9816-OEM Module

Pin	Signal	Pin	Signal
20	Ext Trigger	19	Ext Clock
18	Ground	17	Digital Output 7
16	Digital Output 6	15	Digital Output 5
14	Digital Output 4	13	Digital Output 3
12	Digital Output 2	11	Digital Output 1
10	Digital Output 0	9	Ground
8	Digital Input 7	7	Digital Input 6
6	Digital Input 5	5	Digital Input 4
4	Digital Input 3	3	Digital Input 2
2	Digital Input 1	1	Digital Input 0

Refer to [page 100](#) for information on the USB header.

Connecting Single-Ended Analog Input Signals

The DT9816 Series modules support six single-ended analog input channels.

Figure 7 shows how to connect single-ended voltage input signals (channels 0 and 1, in this case) to the screw terminals of the DT9816, DT9816-A, or DT9816-S module, or to the Analog Input connector of the DT9816-OEM module.

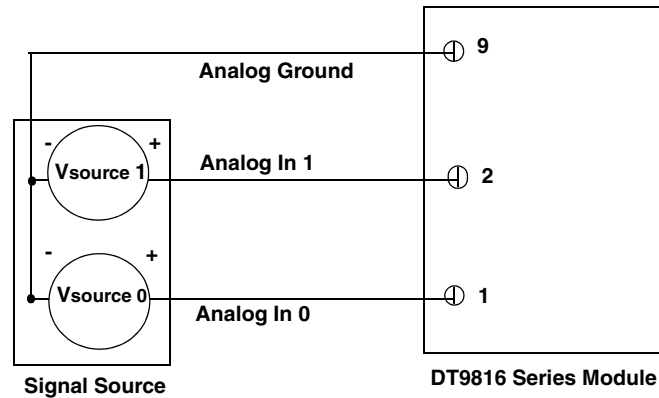

Figure 7: Connecting Single-Ended Inputs to a DT9816 Series Module

Note: When using high sampling rates on the DT9816-S, it is recommended that you use an input impedance of 100 Ω or less.

Connecting Digital Input Signals

Figure 8 shows how to connect digital input signals (lines 0 and 1, in this case) to the screw terminals of the DT9816, DT9816-A, or DT9816-S module.

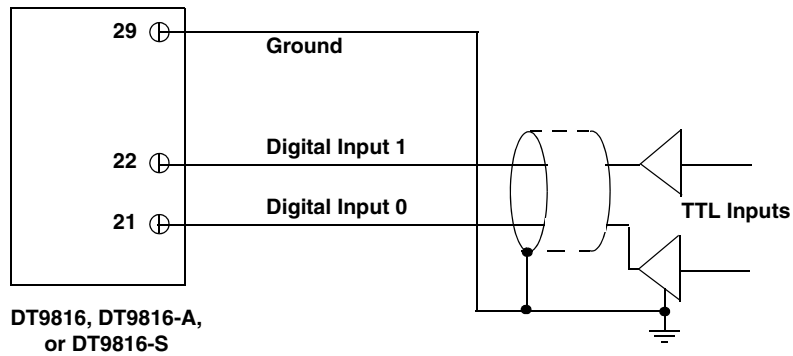

Figure 8: Connecting Digital Inputs to a DT9816, DT9816-A, or DT9816-S Module

Figure 8 shows how to connect digital input signals (lines 0 and 1, in this case) to the Digital I/O connector of the DT9816-OEM module.

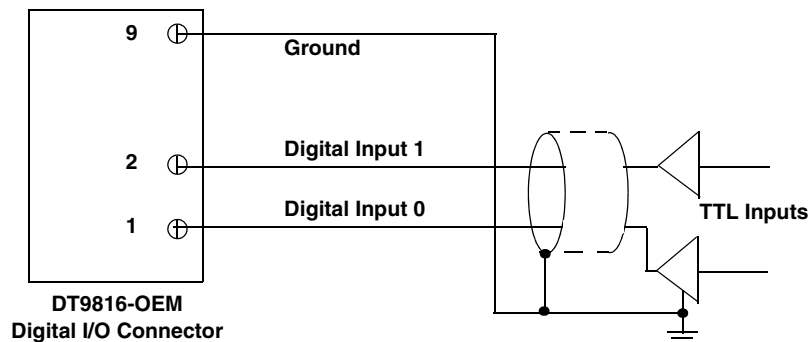

Figure 9: Connecting Digital Inputs to a DT9816-OEM Module

Connecting Digital Output Signals

Figure 10 shows how to connect digital output signals (line 0, in this case) to the screw terminals of the DT9816, DT9816-A, or DT9816-S module.

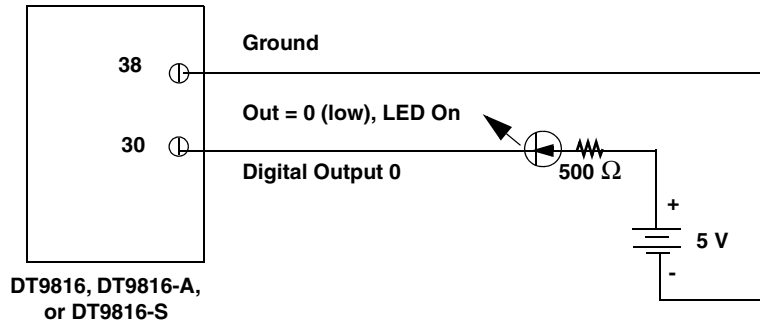

Figure 10: Connecting Digital Outputs to a DT9816, DT9816-A, or DT9816-S Module

Figure 11 shows how to connect digital output signals (line 0, in this case) to the Digital I/O connector of the DT9816-OEM module.

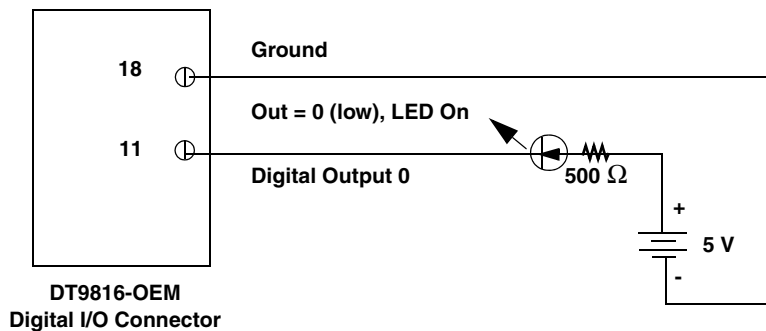

Figure 11: Connecting Digital Outputs to a DT9816-OEM Module

Connecting Counter/Timer Signals

DT9816 Series modules provide one counter/timer that you can use for the following operations:

- Event counting
- Frequency measurement
- Continuous pulse output (rate generation)

To connect counter/timer signals to a DT9816, DT9816-A, or DT9816-S module, use the screw terminals on the module. To connect counter/timer signals to a DT9816-OEM module, use the Analog Input connector.

This section describes how to connect counter/timer signals for these operation modes. Refer to [page 65](#) for more information about using the counter/timers.

Connecting Signals for Event Counting

[Figure 12](#) shows how to connect counter/timer signals to a DT9816 Series module to perform an event counting operation using an external gate.

In this example, the counter counts the number of rising edges that occur on the Counter 0 In signal when the Counter 0 Gate signal is in the active state (as specified by software). Refer to [page 67](#) for more information.

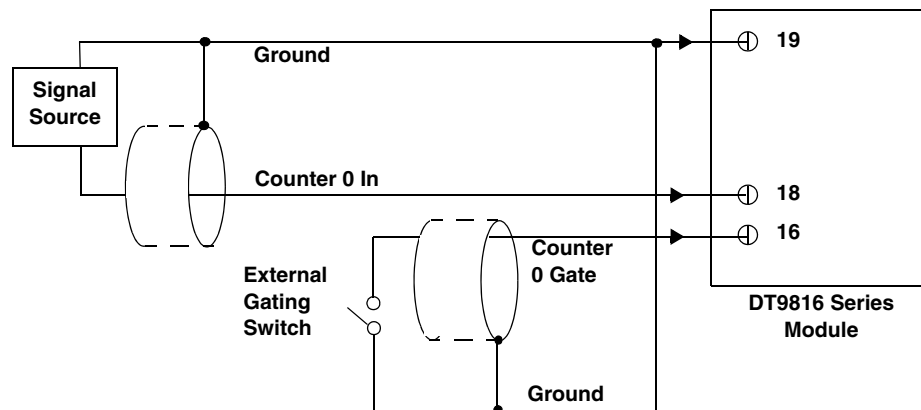

Figure 12: Connecting Counter/Timer Signals for an Event Counting Operation Using an External Gate

[Figure 13](#) shows how to connect counter/timer signals to a DT9816 Series module to perform an event counting operation without using a gate (also called a software gate). The counter counts the number of rising edges that occur on the Counter 0 In signal.

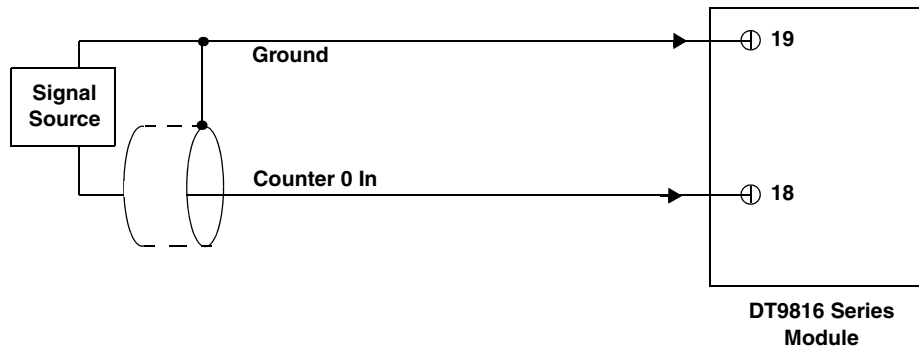

Figure 13: Connecting Counter/Timer Signals for an Event Counting Operation Without Using a Gate

Connecting Signals for Frequency Measurement

One way to measure frequency is to connect a pulse of a known duration to the Counter 0 Gate signal, as shown in [Figure 14](#). In this case, the frequency of the Counter 0 In signal is the number of counts divided by the period of the signal connected to the Counter 0 Gate input.

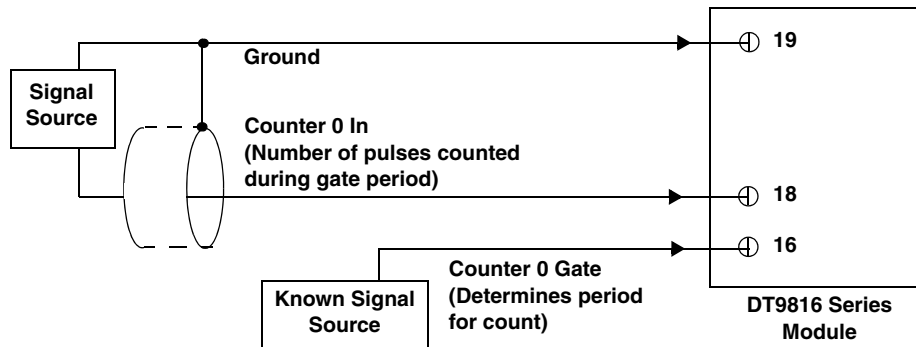

Figure 14: Connecting Counter/Timer Signals for a Frequency Measurement Operation Using an External Pulse

Connecting Signals for Rate Generation

Figure 15 shows how to connect counter/timer signals to a DT9816 Series module to perform a rate generation (continuous pulse output) operation.

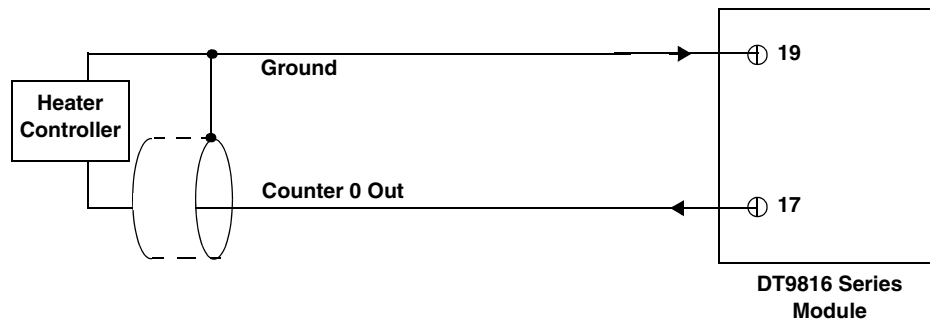
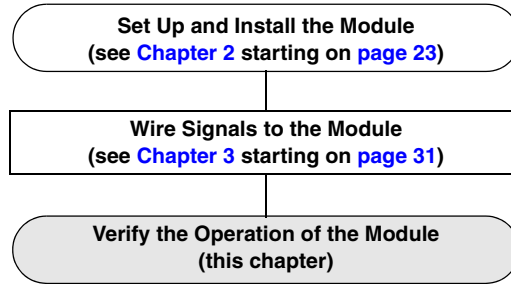

Figure 15: Connecting Counter/Timer Signals for a Rate Generation Operation



Verifying the Operation of a Module

Running the Quick DataAcq Application.....	47
Testing Single-Value Analog Input	48
Testing Continuous Analog Input	49
Testing Single-Value Digital Input.....	50
Testing Single-Value Digital Output	51
Testing Frequency Measurement.....	52
Testing Pulse Output	53



Running the Quick DataAcq Application

The Quick DataAcq application is installed automatically when you install the driver software.

To run the Quick DataAcq application, do the following:

1. If you have not already done so, power up your computer and any attached peripherals.
2. Click **Start** from the Task Bar.
3. Browse to **Programs | Data Translation, Inc | DT-Open Layers for Win32 | QuickDataAcq**.

The main menu appears.

Note: The Quick DataAcq application allows you to verify basic operations on the module; however, it may not support all of the module's features.

For information on each of the features provided, use the online help for the Quick DataAcq application by pressing F1 from any view or selecting the **Help** menu. If the system has trouble finding the help file, navigate to C:\Program Files\Data Translation\Win32\dtdataacq.hlp, where C: is the letter of your hard disk drive.

Testing Single-Value Analog Input

To verify that the module can read a single analog input value, do the following:

1. Connect a voltage source, such as a function generator, to analog input channel 0 (single-ended mode) of a DT9816 Series module. Refer to [page 38](#) for an example of how to connect a single-ended analog input.
2. In the Quick DataAcq application, choose **Single Analog Input** from the **Acquisition** menu.
3. Select the appropriate DT9816 Series module from the **Board** list box.
4. In the **Channel** list box, select analog input channel 0.
5. In the **Range** list box, select the range for the channel (± 10 V).
6. Select **Single Ended**.
7. Click **Get** to acquire a single value from analog input channel 0.
The application displays the value on the screen in both text and graphical form.

Testing Continuous Analog Input

To verify that the module can perform a continuous analog input operation, do the following:

1. Connect known voltage sources, such as the outputs of a function generator, to analog input channels 0 and 1 of a DT9816 Series module (using the single-ended configuration). Refer to [page 38](#) for an example of how to connect a single-ended analog input.
2. In the Quick DataAcq application, choose **Scope** from the **Acquisition** menu.
3. Select the appropriate DT9816 Series module from the **Board** list box.
4. In the **Sec/Div** list box, select the number of seconds per division (.1 to .00001) for the display.
5. In the **Channel** list box, select analog input channel 1, and then click **Add** to add the channel to the channel list.

Note that, by default, channel 0 is included in the channel list.

6. Click **Config** from the Toolbar.
7. In the **Config** dialog, select **ChannelType**, and then select **Single Ended**.
8. In the **Config** dialog, select **Range**, and then select **Bipolar**.
9. From the **Scope** view, double-click the input range of the channel to change the input range of the module.
The display changes to reflect the selected range for all the analog input channels on the module.
10. In the Trigger box, select **Auto** to acquire data continuously from the specified channels or **Manual** to acquire a burst of data from the specified channels.
11. Click **Start** from the Toolbar to start the continuous analog input operation.
The application displays the values acquired from each channel in a unique color on the oscilloscope view.
12. Click **Stop** from the Toolbar to stop the operation.

Testing Single-Value Digital Input

To verify that the module can read a single digital input value, do the following:

1. Connect a digital input to digital input line 0 of port A on a DT9816 Series module. Refer to [page 39](#) for an example of how to connect a digital input.
2. In the Quick DataAcq application, choose **Digital Input** from the **Acquisition** menu.
3. Select the appropriate DT9816 Series module from the **Board** list box.
4. Select digital input port A by clicking **Port A**.
5. Click **Get**.

The application displays the value of each digital input line in port A on the screen in both text and graphical form.

Testing Single-Value Digital Output

To verify that the module can output a single digital output value, do the following:

1. Connect a digital output to digital output line 0 of port B on a DT9816 Series module. Refer to [page 39](#) for an example of how to connect a digital output.
2. In the Quick DataAcq application, select **Digital Output** from the **Control** menu.
3. Select the appropriate DT9816 Series module from the **Board** list box.
4. Select digital output port B by clicking **Port B**.
5. Click the appropriate bits to determine the value to write to the digital output lines. If the bit is selected, a high-level signal is output from the digital output line; if the bit is not selected, a low-level signal is output from the digital output line. Optionally, you can enter an output value in the **Hex** text box.
6. Click **Send**.
The application outputs and displays the value of each digital output line of digital port B on the screen in both text and graphical form.

Testing Frequency Measurement

To verify that the module can perform a frequency measurement operation, do the following:

1. Wire an external clock source to counter/timer 0 on a DT9816 Series module. Refer to [page 42](#) for an example of how to connect signals to a counter/timer for a frequency measurement operation.
2. In the Quick DataAcq application, choose **Frequency Counter** from the **Acquisition** menu.
3. Select the appropriate DT9816 Series module from the **Board** list box.
4. In the **Count Duration** text box, enter the number of seconds during which events will be counted.
5. Click **Start** to start the frequency measurement operation.
The operation automatically stops after the number of seconds you specified has elapsed, and the application displays the frequency on the screen.

If you want to stop the frequency measurement operation when it is in progress, click **Stop**.

Testing Pulse Output

To verify that the module can perform a pulse output operation, do the following:

1. Connect a scope to counter/timer 0 on a DT9816 Series module. Refer to [page 43](#) for an example of how to connect a scope (a pulse output) to counter/timer 0.
2. In the Quick DataAcq application, choose **Pulse Generator** from the **Control** menu.
3. Select the appropriate DT9816 Series module from the **Board** list box.
4. Select **Continuous** to output a continuous pulse stream.
5. Select **High-to-low** to output a falling-edge pulse (the low portion of the total pulse output period is the active portion of the signal).
6. Click **Start** to generate the pulse(s).
The application displays the results both in text and graphical form.
7. Click **Stop** to stop a continuous pulse output operation.

Part 2: Using Your Module



Principles of Operation

Analog Input Features	59
Digital I/O Features	64
Counter/Timer Features	65

Figure 16 shows a block diagram of the DT9816 Series modules.

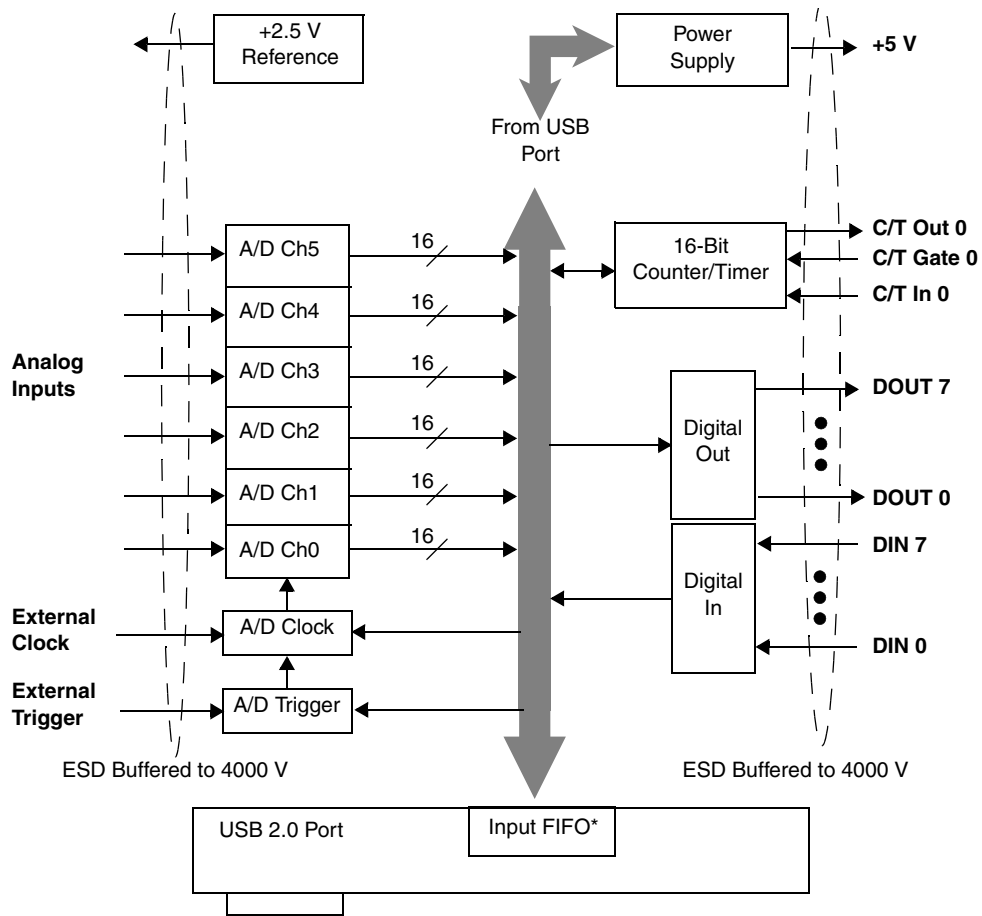

*The DT9816-S has an input FIFO of 8 kSamples. The other models in the DT9816 Series do not have an input FIFO.

Figure 16: Block Diagram of the DT9816 Series Modules

Analog Input Features

This section describes the following analog input (A/D) features of the DT9816 Series modules:

- Input resolution, described below
- Analog input channels, described below
- Input ranges and gains, described on [page 60](#)
- Input sample clock sources, described on [page 60](#)
- Analog input conversion modes, described on [page 61](#)
- Input triggers, described on [page 63](#)
- Data format and transfer, described on [page 63](#)
- Error conditions, described on [page 63](#)

Input Resolution

The resolution of the A/D subsystem on the DT9816 Series modules is 16-bits. This resolution is fixed; it cannot be programmed in software.

Analog Input Channels

DT9816 Series modules provide six single-ended simultaneous analog input channels. You can acquire data from a single analog input channel or from a group of analog input channels on the module.

Note: To maintain simultaneous operation, all analog input connections must have the same lead lengths.

The following subsections describe how to specify the channels.

Specifying a Single Analog Input Channel

The simplest way to acquire data from a single analog input channel is to specify the channel for a single-value analog input operation using software; refer to [page 61](#) for more information about single-value operations.

You can also specify a single channel using the analog input channel list, described in the next section.

Specifying One or More Analog Input Channels

You can read data from one or more analog input channels using an analog input channel list and continuous scan mode.

Using software, specify the channels you want to sample. You can enter up to six entries in the channel list for this module. Group the channels in the list sequentially (starting either with 0 or with any other analog input channel) in ascending order. You cannot specify the same channel more than once in the list.

Refer to [page 62](#) for more information about continuous scan mode.

Input Ranges and Gains

DT9816 Series modules provide an input range of ± 10 V. Use software to specify the range as ± 10 V with a gain of 1 for an effective range of ± 10 V, or specify a gain of 2 for an effective input range of ± 5 V.

Note: You must set the gain to the same value for all channels, even if you are using a subset of the channels.

Input Sample Clock Sources

DT9816 Series modules allow you to use one of the following clock sources to pace analog input operations in continuous mode:

- The internal A/D sample clock
- An external A/D sample clock

The following subsections describe the internal and external A/D sample clocks in more detail.

Internal A/D Sample Clock

You can pace an analog input operation on a DT9816 Series module using an internal clock source. Using software, specify the clock source as internal, and then specify the clock frequency at which to pace the operation. The supported frequencies depend on the model you selected, as shown in [Table 5](#).

Table 5: Supported Clock Frequency

Model	Minimum Frequency	Maximum Frequency
DT9816 and DT9816-OEM	60 Hz	50 kHz
DT9816-A	60 Hz	153.846 kHz
DT9816-S	183.1 Hz	750 kHz

Note: According to sampling theory (Nyquist Theorem), specify a frequency that is at least twice as fast as the input's highest frequency component. For example, to accurately sample a 2 kHz signal, specify a sampling frequency of at least 4 kHz. Doing so avoids an error condition called *aliasing*, in which high frequency input components erroneously appear as lower frequencies after sampling.

When you specify the sampling frequency of the internal clock, the driver determines the actual frequency that the module can achieve by dividing the effective base clock frequency by an internal clock divider. On the DT9816 and DT9816-A modules, the driver divides the base frequency of 48 MHz by 12, which results in an effective base frequency of 4 MHz. On the DT9816-S module, the driver divides the base frequency of 48 MHz by 4, which results in an effective base frequency of 12 MHz. The effective base clock frequency is then divided by an internal clock divider, which is an integer value ranging from 2 to 65534.

It is possible that the actual sampling rate that is configured is different from the value that you specified. For example, assume that you requested a sampling frequency of 42 kHz on the DT9816-S module. To determine the internal clock divider value that is used, you can divide the base clock frequency by the requested sampling frequency. In this example, $12 \text{ MHz} / 42 \text{ kHz}$ results in a clock divider of 285.71. Since only the integer portion of the clock divider is used, the actual sampling frequency is determined by dividing the base clock by the integer portion of the clock divider. In this example, $12 \text{ MHz} / 285$ yields an actual sampling frequency of 42.105263 kHz; this is the frequency that the module uses.

External A/D Sample Clock

An external A/D sample clock is useful when you want to pace acquisitions at rates not available with the internal A/D sample clock or when you want to pace at uneven intervals.

Connect an external A/D sample clock to screw terminal 39 on the DT9816 Series modules or to pin 19 on connector J4 of the DT9816-OEM module.

Using software, specify the clock source as external. For DT9816 Series modules, the clock frequency is always equal to the frequency of the external A/D sample clock input signal that you connect to the module.

Note: The external clock signal has a 22.1 k Ω pull-up to +5 V. Therefore, when this pin is unconnected, the signal goes to +5 V.

Analog Input Conversion Modes

DT9816 Series modules support the following conversion modes:

- Single-value operations
- Continuous scan operations

The following subsections describes the conversion modes in more detail.

Single-Value Operations

Single-value operations are the simplest to use. Using software, you specify the range, gain, and analog input channel. The module acquires the data from the specified channel and returns the data immediately. For a single-value operation, you cannot specify a clock source, trigger source, scan mode, or buffer.

Single-value operations stop automatically when finished; you cannot stop a single-value operation.

Continuous Scan Mode

Use continuous scan mode if you want to accurately control the period between successive simultaneous conversions of all channels in a channel list.

When it receives an initial trigger, the module cycles through the channel list, acquiring and converting the data for each entry in the list (this process is defined as the scan). The module then wraps to the start of the channel list and repeats the process continuously until either all the allocated buffers on the subsystem queue are filled or until you stop the operation. Refer to [page 63](#) for more information about buffers.

The conversion rate is determined by the frequency of the internal sample clock; refer to [page 60](#) for more information about the internal sample clock. The sample rate, which is the rate at which a single entry in the channel list is sampled, is the same as the conversion rate due to the simultaneous nature of the module.

To select continuous scan mode, use software to specify the data flow as Continuous.

[Figure 17](#) illustrates continuous scan mode using a channel list with three entries: channel 0, channel 1, and channel 2. In this example, analog input data is acquired simultaneously on all channels on each clock pulse of the input sample clock. Data is acquired continuously.

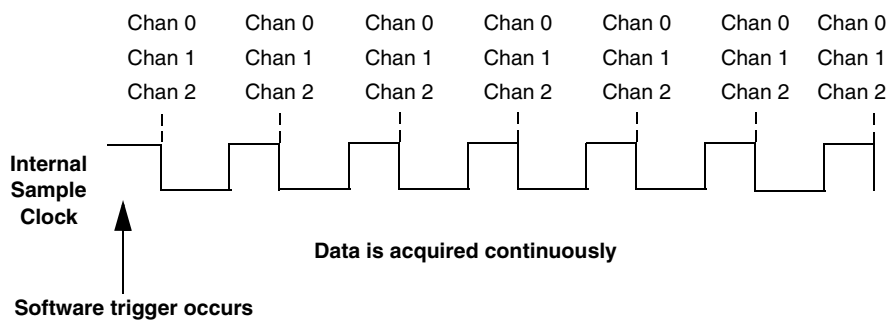

Figure 17: Continuous Scan Mode

Input Triggers

A trigger is an event that occurs based on a specified set of conditions. Acquisition starts when the module detects the initial trigger event and stops when either no more buffers are available or you stop the operation.

DT9816 Series modules support the following trigger sources:

- **Software trigger** – A software trigger event occurs when you start the analog input operation (the computer issues a write to the module to begin conversions). Using software, specify the trigger source as a software trigger.
- **External digital (TTL) trigger** – The external trigger is initiated by a falling-edge transition on the A/D external TTL trigger input. Using software, specify the trigger source as an external, negative digital (TTL) trigger.

Note: This signal has a 22.1 k Ω pull-up to +5 V. Therefore, when this pin is unconnected, the signal goes to +5 V.

Data Format and Transfer

DT9816 Series modules use binary data encoding, where 0000 represents negative full-scale, and FFFFh represents positive full-scale. Use software to specify the data encoding as binary. The ADC outputs FFFFh for above-range signals, and 0000 for below-range signals.

Before you begin acquiring data, you must allocate buffers to hold the data. A buffer done event is returned whenever a buffer is filled. This allows you to move and/or process the data as needed.

We recommend that you allocate a minimum of two buffers for a continuous analog input operation. Data is written to multiple allocated input buffers continuously; when no more empty buffers are available, the operation stops. The data is gap-free.

Error Conditions

An overrun condition is reported if the A/D sample clock rate is too fast. This error is reported if a new A/D sample clock pulse occurs while the ADC is busy performing a conversion from the previous A/D sample clock pulse. The host computer can clear this error. To avoid this error, use a slower sampling rate or increase the buffer size and/or number of buffers.

Digital I/O Features

This section describes the following digital I/O features of the DT9816 Series modules:

- Digital I/O lines
- Resolution
- Operation modes

Digital I/O Lines

DT9816 Series modules provide 8 digital input and 8 digital output lines.

Using software, you can specify the digital I/O line that you want to read or write in a single-value digital I/O operation. Refer to [page 64](#) for more information about single-value operations.

A digital line is high if its value is 1; a digital line is low if its value is 0. On power up or reset, a low value (0) is output from each of the digital output lines.

Resolution

The resolution of the digital input port is 8-bits; the resolution of the digital output port is 8-bits. The resolution is fixed; it cannot be programmed in software.

Operation Modes

DT9816 Series modules support single-value digital I/O operations only. For a single-value operation, use software to specify the digital I/O port (the gain is ignored). The module then reads data from or writes data to the digital lines associated with that port.

Single-value operations stop automatically when finished; you cannot stop a single-value operation.

Counter/Timer Features

This section describes the following counter/timer (C/T) features of the DT9816 Series modules:

- C/T channel, described below
- C/T clock sources, described on [page 66](#)
- Gate types, described on [page 66](#)
- Pulse types and duty cycles, described on [page 66](#)
- C/T operation modes, described on [page 67](#)

C/T Channel

DT9816 Series modules provide one 16-bit counter/timer. The counter accepts a clock input signal and a gate input signal and outputs a pulse (pulse output signal), as shown in [Figure 18](#).

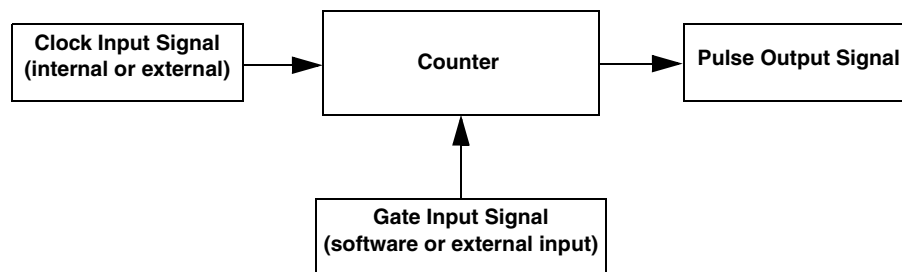

Figure 18: Counter/Timer Channel

C/T Clock Sources

The following clock sources are available for the counter/timer:

- **Internal clock** – Through software, specify the clock source as internal, and specify the frequency at which to pace the counter/timer operation. The frequency of the internal C/T clock can range from 60 Hz to 6 MHz.
- **External clock** – An external clock is useful when you want to pace counter/timer operations at rates not available with the internal clock or if you want to pace at uneven intervals.

Connect an external clock with a maximum recommended frequency of 6 MHz to the Counter 0 In signal on a DT9816 Series module. Using software, specify the C/T clock source as external, and specify a clock divider between 2 and 65534 to determine the actual frequency at which to pace the counter/timer operation. For example, if you connect a 6 MHz external C/T clock and use a clock divider of 2, the resulting C/T output frequency is 3 MHz. Counter/timer operations start on the falling edge of the Counter 0 In signal.

Note: This signal has a 22.1 k Ω pull-up to +5 V. Therefore, when this pin is unconnected, the signal goes to +5 V.

Gate Types

The edge or level of the Counter 0 Gate signal determines when a counter/timer operation is enabled. Using software, you can specify one of the following gate types:

- **None** – A software command enables any counter/timer operation immediately after execution.
- **Logic-high level external gate input** – Enables a counter/timer operation when Counter 0 Gate is high, and disables a counter/timer operation when Counter 0 Gate is low. Note that this gate type is used for event counting and rate generation modes; refer to [page 67](#) for more information about these modes.

Pulse Duty Cycles

Counter/timer output signals from a DT9816 Series module are high-to-low going signals. The low portion of the total pulse output period is the active portion of the counter/timer clock output signal.

The duty cycle (or pulse width) indicates the percentage of the total pulse output period that is active. In rate generation mode, the duty cycle is fixed at 50% for the DT9816 Series modules. [Figure 19](#) illustrates a high-to-low going output pulse with a duty cycle of 50%.

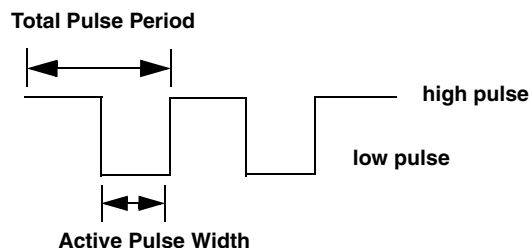

Figure 19: Example of a Pulse Output Signal with a 50% Duty Cycle (High-to-Low Going)

Counter/Timer Operation Modes

DT9816 Series modules support the following counter/timer operation modes:

- Event counting
- Frequency measurement
- Rate generation

Event Counting

Use event counting mode if you want to count the number of falling edges that occur on Counter 0 In when the gate is active (high-level). Refer to [page 66](#) for information about specifying the active gate type.

You can count a maximum of 65,536 events before the counter rolls over to 0 and starts counting again.

For event counting operations, use software to specify the counter/timer mode as count, the C/T clock source as external, and the active gate type as high-level.

Make sure that the signals are wired appropriately. Refer to [page 41](#) for an example of connecting an event counting application.

Frequency Measurement

Connect a pulse of a known duration to the Counter 0 Gate signal. Specify the active gate in software (high level). When the operation starts, read the number of counts that occurred when the gate was active.

You can determine the frequency of the clock input signal using the following equation:

$$\text{Frequency Measurement} = \frac{\text{Number of Events}}{\text{Measurement Period}}$$

Make sure that the signals are wired appropriately. Refer to [page 42](#) for an example of connecting a frequency measurement application.

Rate Generation

Use rate generation mode to generate a continuous pulse output signal from Counter 0 Out; this mode is sometimes referred to as continuous pulse output or pulse train output.

The pulse output operation is enabled whenever the Counter 0 Gate signal is active (high level or software gate). While the pulse output operation is enabled, the counter outputs a high-to-low going pulse with a pulse width of 50% continuously. As soon as the operation is disabled, rate generation stops.

The frequency of the output signal is determined by the C/T clock source (either internal or external) and, for an external clock source, the clock divider used. You can generate an output signal from Counter 0 Out with a frequency of 60 Hz to 6 MHz.

To specify rate generation mode, use software to specify the counter/timer mode as rate, the C/T clock source as either internal or external, the clock divider (2 to 65534) if an external clock source is used, and the active gate type (low-level, high-level, or software gate). Refer to [page 66](#) for more information about gate types.

Make sure that the signals are wired appropriately. Refer to [page 43](#) for an example of connecting a rate generation application.



Supported Device Driver Capabilities

Data Flow and Operation Options.....	71
Buffering	72
Triggered Scan Mode	72
Data Encoding.....	72
Channels	73
Gain	73
Ranges	74
Resolution	74
Current and Resistance Support	74
Thermocouple, RTD, and Thermistor Support	75
IEPE Support.....	76
Bridge and Strain Gage Support	76
Start Triggers.....	77
Reference Triggers	77
Clocks.....	78
Counter/Timers	79
Tachometers.....	80

The DT9816 Series Device Driver provides support for the analog input (A/D), digital input (DIN), digital output (DOUT), and counter/timer (C/T) subsystems. For information on how to configure the device driver, refer to [page 30](#).

Table 6: DT9816 Series Subsystems

DT9816 Series	A/D	D/A	DIN	DOUT	C/T	TACH	QUAD
Total Subsystems on Module	1	0	1	1	1	0	0

The tables in this chapter summarize the features available for use with the DT-Open Layers for .NET Class Library and the DT9816 Series modules. The DT-Open Layers for .NET Class Library provides properties that return support information for specified subsystem capabilities.

The first row in each table lists the subsystem types. The first column in each table lists all possible subsystem capabilities. A description of each capability is followed by the property used to describe that capability in the DT-Open Layers for .NET Class Library.

Note: The following tables include the capabilities that can be queried. However, some capabilities may not be supported by your device. Blank fields represent unsupported options.

For more information, refer to the description of these properties in the DT-Open Layers for .NET Class Library online help or *DT-Open Layers for .NET Class Library User's Manual*.

Data Flow and Operation Options

Table 7: Data Flow and Operation Options

DT9816 Series	A/D	D/A	DIN	DOUT	C/T	TACH	QUAD
Single-Value Operation Support SupportsSingleValue	Yes		Yes	Yes			
Simultaneous Single-Value Output Operations SupportsSetSingleValues							
Continuous Operation Support SupportsContinuous	Yes				Yes		
Continuous Operation until Trigger SupportsContinuousPreTrigger							
Continuous Operation before & after Trigger SupportsContinuousPrePostTrigger							
Waveform Operations Using FIFO Only SupportsWaveformModeOnly							
Simultaneous Start List Support SupportsSimultaneousStart							
Supports Programmable Synchronization Modes SupportsSynchronization							
Synchronization Modes SynchronizationMode							
Interrupt Support SupportsInterruptOnChange							
FIFO Size, in Samples FifoSize	8 kSample ^a						
Muting and Unmuting the Output Voltage SupportsMute							
Auto-Calibrate Support SupportsAutoCalibrate							

a. The DT9816-S has an input FIFO of 8 kSamples. The other models in the DT9816 Series do not have an input FIFO.

Buffering

Table 8: Buffering Options

DT9816 Series	A/D	D/A	DIN	DOUT	C/T	TACH	QUAD
Buffer Support SupportsBuffering	Yes						
Single Buffer Wrap Mode Support SupportsWrapSingle							
Inprocess Buffer Flush Support SupportsInProcessFlush	Yes						

Triggered Scan Mode

Table 9: Triggered Scan Mode Options

DT9816 Series	A/D	D/A	DIN	DOUT	C/T	TACH	QUAD
Triggered Scan Support SupportsTriggeredScan							
Maximum Number of CGL Scans per Trigger MaxMultiScanCount	0		0	0	0		
Maximum Retrigger Frequency MaxRetriggerFreq	0		0	0	0		
Minimum Retrigger Frequency MinRetriggerFreq	0		0	0	0		

Data Encoding

Table 10: Data Encoding Options

DT9816 Series	A/D	D/A	DIN	DOUT	C/T	TACH	QUAD
Binary Encoding Support SupportsBinaryEncoding	Yes		Yes	Yes	Yes		
Twos Complement Support SupportsTwosCompEncoding							
Returns Floating-Point Values ReturnsFloats							

Channels

Table 11: Channel Options

DT9816 Series	A/D	D/A	DIN	DOUT	C/T	TACH	QUAD
Number of Channels NumberOfChannels	6 ^a		1	1	1		
SE Support SupportsSingleEnded	Yes						
SE Channels MaxSingleEndedChannels	6		0	0	0		
DI Support SupportsDifferential			Yes	Yes	Yes		
DI Channels MaxDifferentialChannels	0		1	1	1		
Maximum Channel-Gain List Depth CGLDepth	6 ^b		0	0	0		
Simultaneous Sample-and-Hold Support SupportsSimultaneousSampleHold	Yes						
Channel-List Inhibit SupportsChannelListInhibit							
Support MultiSensor Inputs SupportsMultiSensor							
Bias Return Termination Resistor Support SupportsInputTermination							

- a. The DT9816 Series provides analog input channels 0 to 5.
 b. You cannot specify the same channel more than once in the list. Place channels in your channel list in ascending order. All channels are sampled simultaneously with data returned in ascending channel order; if your channel does not match, you will have unexpected results.

Gain

Table 12: Gain Options

DT9816 Series	A/D	D/A	DIN	DOUT	C/T	TACH	QUAD
Programmable Gain Support SupportsProgrammableGain	Yes						
Number of Gains NumberOfSupportedGains	2		1	1	0		
Gains Available SupportedGains	1, 2 ^a		1	1			

- a. A gain of 1 sets the effective input range to ± 10 V; a gain of 2 sets the effective input range to ± 5 V. You must set the gain to the same value for all channels, even if you are using a subset of the channels.

Ranges

Table 13: Range Options

DT9816 Series	A/D	D/A	DIN	DOUT	C/T	TACH	QUAD
Number of Voltage Ranges NumberOfRanges	1		0	0	0		
Available Ranges SupportedVoltageRanges	±10 V						

Resolution

Table 14: Resolution Options

DT9816 Series	A/D	D/A	DIN	DOUT	C/T	TACH	QUAD
Software Programmable Resolution SupportsSoftwareResolution							
Number of Resolutions NumberOfResolutions	1		1	1	1		
Available Resolutions SupportedResolutions	16		8	8	16		

Current and Resistance Support

Table 15: Current and Resistance Support Options

DT9816 Series	A/D	D/A	DIN	DOUT	C/T	TACH	QUAD
Current Support SupportsCurrent							
Current Output Support SupportsCurrentOutput							
Resistance Support SupportsResistance							
Software Programmable External Excitation Current Source for Resistance SupportsExternalExcitationCurrentSrc							
Software Programmable Internal Excitation Current Source SupportsInternalExcitationCurrentSrc							
Available Excitation Current Source Values SupportedExcitationCurrentValues							

Thermocouple, RTD, and Thermistor Support

Table 16: Thermocouple, RTD, and Thermistor Support Options

DT9816 Series	A/D	D/A	DIN	DOUT	C/T	TACH	QUAD
Thermocouple Support SupportsThernocouple							
RTD Support SupportsRTD							
Thermistor Support SupportsThermistor							
Voltage Converted to Temperature SupportsTemperatureDataInStream							
Supported Thermocouple Types ThermocoupleType							
Supported RTD Types RTDType							
Supports CJC Source Internally in Hardware SupportsCjcSourceInternal							
Supports CJC Channel SupportsCjcSourceChannel							
Available CJC Channels CjcChannel							
Supports Interleaved CJC Values in Data Stream SupportsInterleavedCjcTemperaturesInStream							
Supported RTD Types RTDType							
RTD R0 Coefficient RtdR0							
Supports Temperature Filters SupportsTemperatureFilters							
Temperature Filter Types TemperatureFilterType							

IEPE Support

Table 17: IEPE Support Options

DT9816 Series	A/D	D/A	DIN	DOUT	C/T	TACH	QUAD
IEPE Support SupportsIEPE							
Software Programmable AC Coupling SupportsACCoupling							
Software Programmable DC Coupling SupportsDCCoupling							
Software Programmable External Excitation Current Source SupportsExternalExcitationCurrentSrc							
Software Programmable Internal Excitation Current Source SupportsInternalExcitationCurrentSrc							
Available Excitation Current Source Values SupportedExcitationCurrentValues							

Bridge and Strain Gage Support

Table 18: Bridge and Strain Gage Support Options

DT9816 Series	A/D	D/A	DIN	DOUT	C/T	TACH	QUAD
Bridge Support SupportsBridge							
Supported Bridge Configurations BridgeConfiguration							
Strain Gage Support SupportsStrainGage							
Supported Strain Gage Bridge Configurations StrainGageBridgeConfiguration							
External Excitation Voltage SupportsExternalExcitationVoltage							
Internal Excitation Voltage SupportsInternalExcitationVoltage							
Shunt Calibration SupportsShuntCalibration							
Voltage Excitation Per Channel SupportedPerChannelVoltageExcitation							
Minimum Excitation Voltage MinExcitationVoltage							
Maximum Excitation Voltage MaxExcitationVoltage							

Start Triggers

Table 19: Start Trigger Options

DT9816 Series	A/D	D/A	DIN	DOUT	C/T	TACH	QUAD
Software Trigger Support SupportsSoftwareTrigger	Yes				Yes		
External Positive TTL Trigger Support SupportsPosExternalTTLTrigger					Yes		
External Negative TTL Trigger Support SupportsNegExternalTTLTrigger	Yes						
External Positive TTL Trigger Support for Single-Value Operations SupportsSvPosExternalTTLTrigger							
External Negative TTL Trigger Support for Single-Value Operations SupportsSvNegExternalTTLTrigger							
Positive Threshold Trigger Support SupportsPosThresholdTrigger							
Negative Threshold Trigger Support SupportsNegThresholdTrigger							
Digital Event Trigger Support SupportsDigitalEventTrigger							
Threshold Trigger Channel SupportedThresholdTriggerChannel		0					
Post-Trigger Scan Count SupportsPostTriggerScanCount							

Reference Triggers

Table 20: Reference Trigger Options

DT9816 Series	A/D	D/A	DIN	DOUT	C/T	TACH	QUAD
External Positive TTL Trigger Support SupportsPosExternalTTLTrigger							
External Negative TTL Trigger Support SupportsNegExternalTTLTrigger							
Positive Threshold Trigger Support SupportsPosThresholdTrigger							
Negative Threshold Trigger Support SupportsNegThresholdTrigger							
Digital Event Trigger Support SupportsDigitalEventTrigger							
Threshold Trigger Channel SupportedThresholdTriggerChannel							
Sync Bus Support SupportsSyncBusTrigger							
Post-Trigger Scan Count SupportsPostTriggerScanCount							

Clocks

Table 21: Clock Options

DT9816 Series	A/D	D/A	DIN	DOUT	C/T	TACH	QUAD
Internal Clock Support SupportsInternalClock	Yes				Yes		
External Clock Support SupportsExternalClock	Yes				Yes		
Simultaneous Input/Output on a Single Clock Signal SupportsSimultaneousClocking	Yes						
Base Clock Frequency BaseClockFrequency	48 MHz ^a		0	0	48 MHz		
Maximum Clock Divider MaxExtClockDivider	1		0	0	65534 ^b		
Minimum Clock Divider MinExtClockDivider	1		1	1	2		
Maximum Frequency MaxFrequency	50 kHz, 153.846 kHz, or 750 kHz ^c		1	1	6 MHz		
Minimum Frequency MinFrequency	61 Hz or 183.1 Hz ^d		0	0	60 Hz		

- a. On the DT9816 and DT9816-A, the base clock frequency is divided by 12, resulting in an effective base clock frequency of 4 MHz. On the DT9816-S, the base clock frequency is divided by 4, resulting in an effective base clock frequency of 12 MHz. The driver divides the effective base clock frequency by an internal clock divider from 2 to 65534 to achieve the desired sampling frequency.
- b. The module supports only even number values for the clock divider. Odd values are rounded down.
- c. The DT9816 and DT9816-OEM modules support a maximum frequency of 50 kHz, the DT9816-A supports a maximum frequency of 153.846 kHz, and the DT9816-S supports a maximum frequency of 750 kHz.
- d. For the DT9816, DT9816-A, and DT9816-OEM, the minimum frequency is 61 Hz. For the DT9816-S, the minimum frequency is 183.1 Hz.

Counter/Timers

Table 22: Counter/Timer Options

DT9816 Series	A/D	D/A	DIN	DOUT	C/T	TACH	QUAD
Cascading Support SupportsCascading							
Event Count Mode Support SupportsCount					Yes		
Generate Rate Mode Support SupportsRateGenerate					Yes		
One-Shot Mode Support SupportsOneShot							
Repetitive One-Shot Mode Support SupportsOneShotRepeat							
Up/Down Counting Mode Support SupportsUpDown							
Edge-to-Edge Measurement Mode Support SupportsMeasure							
Continuous Edge-to-Edge Measurement Mode Support SupportsContinuousMeasure							
High to Low Output Pulse Support SupportsHighToLowPulse					Yes		
Low to High Output Pulse Support SupportsLowToHighPulse							
Variable Pulse Width Support SupportsVariablePulseWidth					No ^a		
None (internal) Gate Type Support SupportsGateNone					Yes		
High Level Gate Type Support SupportsGateHighLevel					Yes		
Low Level Gate Type Support SupportsGateLowLevel							
High Edge Gate Type Support SupportsGateHighEdge							
Low Edge Gate Type Support SupportsGateLowEdge							
Level Change Gate Type Support SupportsGateLevel							
Clock-Falling Edge Type SupportsClockFalling							
Clock-Rising Edge Type SupportsClockRising							
Gate-Falling Edge Type SupportsGateFalling							

Table 22: Counter/Timer Options (cont.)

DT9816 Series	A/D	D/A	DIN	DOUT	C/T	TACH	QUAD
Gate-Rising Edge Type SupportsGateRising							
Interrupt-Driven Operations SupportsInterrupt					Yes		

a. The pulse width (duty cycle) is fixed at 50% when rate generation mode is used.

Tachometers

Table 23: Tachometer Options

DT9816 Series	A/D	D/A	DIN	DOUT	C/T	TACH	QUAD
Tachometer Falling Edges SupportsFallingEdge							
Tachometer Rising Edges SupportsRisingEdge							
Tachometer Stale Data Flag SupportsStaleDataFlag							



Troubleshooting

General Checklist	82
Technical Support	84
If Your Module Needs Factory Service	85

General Checklist

Should you experience problems using a DT9816 Series module, do the following:

1. Read all the documentation provided for your product, including any “Read This First” information.
2. Check the OMNI CD for any README files and ensure that you have used the latest installation and configuration information available.
3. Check that your system meets the requirements stated on [page 26](#).
4. Check that you have installed your hardware properly using the instructions in [Chapter 2](#).
5. Check that you have configured the device driver properly using the instructions in [Chapter 2](#).
6. Check that you have wired your signals properly using the instructions in [Chapter 3](#).
7. Search the DT Knowledgebase in the Support section of the Data Translation web site (at www.datatranslation.com) for an answer to your problem.
8. Visit the product’s page on the Data Translation web site for the latest tips, white papers, product documentation, and software fixes.

If you still experience problems, try using the information in [Table 24](#) to isolate and solve the problem. If you cannot identify the problem, refer to [page 82](#).

Table 24: Troubleshooting Problems

Symptom	Possible Cause	Possible Solution
Module is not recognized	You plugged the module into your computer before installing the device driver.	From the Control Panel > System > Hardware > Device Manager, uninstall any unknown devices (showing a yellow question mark). Then, run the setup program on your OMNI CD to install the USB device drivers, and reconnect your USB module to the computer.
Module does not respond.	The module configuration is incorrect.	Check the configuration of your device driver; see the instructions in Chapter 2 .
	The module is damaged.	Contact Data Translation for technical support; refer to page 84 .
Intermittent operation.	Loose connections or vibrations exist.	Check your wiring and tighten any loose connections or cushion vibration sources; see the instructions in Chapter 3 .
	The module is overheating.	Check environmental and ambient temperature; consult the module’s specifications on page 94 of this manual and the documentation provided by your computer manufacturer for more information.
	Electrical noise exists.	Check your wiring and either provide better shielding or reroute unshielded wiring; see the instructions in Chapter 3 .

Table 24: Troubleshooting Problems (cont.)

Symptom	Possible Cause	Possible Solution
Device failure error reported.	The module cannot communicate with the Microsoft bus driver or a problem with the bus driver exists.	Check your cabling and wiring and tighten any loose connections; see the instructions in Chapter 3 .
	The module was removed while an operation was being performed.	Ensure that your module is properly connected; see the instructions in Chapter 2 .
Data appears to be invalid.	An open connection exists.	Check your wiring and fix any open connections; see the instructions in Chapter 3 .
	A transducer is not connected to the channel being read.	Check the transducer connections; see the instructions in Chapter 3 .
	The transducer is set up for differential inputs.	Check your wiring and ensure that your transducer is set up for single-ended inputs; see the instructions in Chapter 3 .
	The DT9816 Series module is out of calibration.	DT9816 Series modules are calibrated at the factory and should not require recalibration. If you want to readjust the calibration of the analog input circuitry, refer to the instructions on the Data Translation web site (www.datatranslation.com).
Computer does not boot.	The power supply of the computer is too small to handle all the system resources.	Check the power requirements of your system resources and, if needed, get a larger power supply; consult the module's specifications on page 94 of this manual.
USB 2.0 is not recognized.	Your operating system does not have the appropriate Service Pack installed.	Ensure that you load the appropriate Windows Service Pack (version 2 for Windows XP). If you are unsure of whether you are using USB 2.0 or USB 1.1, run the Open Layers Control Panel applet, described in Chapter 2 .
	Standby mode is enabled on your PC.	For some PCs, you may need to disable standby mode on your system for proper USB 2.0 operation. Consult Microsoft for more information.

Technical Support

If you have difficulty using a DT9816 Series module, Data Translation's Technical Support Department is available to provide technical assistance.

To request technical support, go to our web site at <http://www.datatranslation.com> and click on the Support link.

When requesting technical support, be prepared to provide the following information:

- Your product serial number
- The hardware/software product you need help on
- The version of the OMNI CD you are using
- Your contract number, if applicable

If you are located outside the USA, contact your local distributor; see our web site (www.datatranslation.com) for the name and telephone number of your nearest distributor.

If Your Module Needs Factory Service

If your module must be returned to Data Translation, do the following:

1. Record the module's serial number, then contact the Customer Service Department at (508) 481-3700, ext. 1323 (if you are in the USA) and obtain a Return Material Authorization (RMA).

If you are located outside the USA, call your local distributor for authorization and shipping instructions. The name and telephone number of your nearest distributor are listed on Data Translation's web site. All return shipments to Data Translation must be marked with the correct RMA number to ensure proper processing.

2. Using the original packing materials, if available, package the module as follows:
 - Wrap the module in an electrically conductive plastic material. Handle with ground protection. A static discharge can destroy components on the module.
 - Place in a secure shipping container.
3. Return the module to the following address, making sure the RMA number is visible on the outside of the box.

Customer Service Dept.
Data Translation, Inc.
100 Locke Drive
Marlboro, MA 01752-1192



Specifications

Analog Input Specifications	88
Digital I/O Specifications	90
Counter/Timer Specifications	91
External Trigger Specifications	92
External Clock Specifications	93
Power, Physical, and Environmental Specifications	94
Regulatory Specifications	95
Mating Connector Specifications	96

Analog Input Specifications

Table 25 lists the specifications for the analog input subsystem on a DT9816 Series module.

Table 25: Analog Input Subsystem Specifications

Feature	Specifications
Number of analog input channels	6 single-ended
Number of gains	2 (1, 2)
Resolution	16-bit
Data encoding	offset binary
System accuracy, to % of FSR (Averaged over 50 readings)	$\pm 0.08\%$ typical @ gain of 1
Range	± 10 V, ± 5 V
Nonlinearity	0.015%
Differential nonlinearity	0.003%
Inherent quantizing error	$\pm 1/2$ LSB
Drift Zero: Gain:	± 25 $\mu\text{V}/^\circ\text{C}$ ± 50 ppm/ $^\circ\text{C}$
Differential linearity:	monotonic to 14 bits
Input impedance ^a Off channel: On channel:	– 10 M Ω , 10 pf
Input bias current	± 10 nA
Maximum input voltage (without damage) Power on: Power off:	± 35 V ± 20 V
A/D conversion time DT9816 and DT9816-OEM: DT9816-A: DT9816-S:	8 μs 4 μs 950 ns
Channel acquisition time ($\pm 1/2$ LSB)	1 μs
Sample-and-hold Aperture uncertainty: Aperture delay: Aperture match: Gain match: Zero match:	1 ns 35 ns 5 ns 0.05% ± 3.0 mV
Maximum throughput DT9816 and DT9816-OEM: DT9816-A: DT9816-S:	50 kHz per channel 153.846 kHz per channel 750 kHz per channel

Table 25: Analog Input Subsystem Specifications (cont.)

Feature	Specifications
Signal bandwidth (to -3 dB point) DT9816 and DT9816-OEM: DT9816-A: DT9816-S:	4 MHz typical 4 MHz typical 40 MHz typical
ESD protection (per spec) Arc: Contact:	8 kV 4 kV
Reference	2.5 V
Monotonicity	Yes
Input FIFO DT9816-S: Other DT9816 Series modules:	8 kSamples None

- a. Very high input impedance minimizes any source error. When using high sampling rates on the DT9816-S, it is recommended that you use an input impedance of 100 Ω or less.

Digital I/O Specifications

Table 26 lists the specifications for the digital input and digital output subsystems on a DT9816 Series module.

Table 26: Digital I/O Subsystem Specifications

Feature	Specifications
Number of digital I/O lines	16 (8 each; dedicated)
Number of ports	2, 8-bit
Input termination	Series 1 k Ω ; Series 33.2 Ω
Logic family	TTL
Logic sense	Positive true
Inputs Input type: Input logic load: High input voltage: Low input voltage: Low input current:	Level sensitive 1 TTL Load 2.4 V min 0.8 V max -0.4 mA max
Outputs High output: Low output: High output current (source): Low output current (sink):	2.8 V min 0.6 V max 4.5 mA 10 mA
Software I/O selectable	Yes
ESD protection (per spec) Arc: Contact:	8 kV 4 kV

Counter/Timer Specifications

Table 27 lists the specifications for the counter/timer subsystem on a DT9816 Series module.

Table 27: Counter/Timer Subsystem Specifications

Feature	Specifications
Number of counter/timers	1
Counter/timer modes	Event counting, frequency measurement, rate generation
Resolution	16-bit
Minimum pulse width: (minimum amount of time it takes a C/T to recognize an input pulse)	25 ns
Logic family	TTL
Inputs ^a Input logic load: High input voltage: Low input voltage: Low input current:	Level sensitive 1 TTL Load 2.4 V min 0.8 V max -0.4 mA max
Outputs High output: Low output: High output current (source): Low output current (sink):	2.8 V min 0.6 V max 2 mA 12 mA
ESD protection (per spec) Arc: Contact:	8 kV 4 kV
Internal clock frequency	60 Hz to 6 MHz
External clock divider	2 to 65534

- a. Counter 0 In has a 22.1 k Ω pull-up to +5 V. Therefore, when this pin is unconnected, the signal goes to +5 V.

External Trigger Specifications

Table 28 lists the external A/D trigger specifications for the DT9816 Series modules.

Table 28: External A/D Trigger Specifications

Feature	DT9816 Series Specifications
Input type	HCT rising-edge sensitive ^a
Inputs High input voltage: Low input voltage:	2.4 V min 0.8 V max
Minimum pulse width High: Low:	84 ns 84 ns
Maximum frequency	5.95 MHz

- a. The external trigger input has a 22.1 k Ω pull-up to +5 V. Therefore, when this pin is unconnected, the signal goes to +5 V.

External Clock Specifications

Table 29 lists the external A/D clock specifications DT9816 Series modules.

Table 29: External A/D Clock Specifications

Feature	DT9816 Series Specifications
Input type	HCT rising-edge sensitive ^a
Inputs High input voltage: Low input voltage:	2.4 V min 0.8 V max
Minimum pulse width High: Low:	3.4 μ s (666.7 ns for DT9816-S) 3.3 μ s (666.7 ns for DT9816-S)
Maximum frequency	150 kHz (750 kHz for DT9816-S)
External clock divider	1 ^b

- a. The external clock input has a 22.1 k Ω pull-up to +5 V. Therefore, when this pin is unconnected, the signal goes to +5 V.
- b. On the DT9816 and DT9816-A, the base clock frequency of the internal clock is divided by 12, resulting in an effective base clock frequency of 4 MHz for the internal clock. On the DT9816-S, the internal base clock frequency is divided by 4, resulting in an effective base clock frequency of 12 MHz for the internal clock. The driver divides the effective base clock frequency by an internal clock divider from 2 to 65534 to achieve the desired sampling frequency.

Power, Physical, and Environmental Specifications

Table 30 lists the power, physical, and environmental specifications for the DT9816 Series modules.

Table 30: Power, Physical, and Environmental Specifications

Feature	Specifications
Power +5 V Enumeration: Operation:	< 100 mA < 250 mA
Physical Dimensions (board): Dimensions (box with screw terminals and feet): Weight (board): Weight (box with screw terminals and feet):	100 mm (L) x 100 mm (W) x 15.5 mm (H) 107.7 mm (L) x 100 mm (W) x 33.5 mm (H) 65.8 g 138.8 g
Environmental Operating temperature range: Storage temperature range: Relative humidity:	0 to 55° C –40 to 85° C to 95% non-condensing

Regulatory Specifications

The DT9816 Series modules are CE-compliant. [Table 31](#) lists the regulatory specifications for the DT9816 Series modules.

Table 31: Regulatory Specifications

Feature	DT9812 Series, DT9813 Series, DT9814 Series Specifications
Emissions (EMI)	FCC Part 15, Class A EN55011:2007 (Based on CISPR-11, 2003/A2, 2006)
Immunity	EN61326-1:2006 Electrical Equipment for Measurement, Control, and Laboratory Use <u>EMC Requirements</u> EN61000-4-2:2009 Electrostatic Discharge (ESD) 4 kV contact discharge, 8 kV air discharge, 4 kV horizontal and vertical coupling planes EN61000-4-3:2006 Radiated electromagnetic fields, 3 V/m, 80 to 1000 MHz; 3 V/m, 1.4 GHz to 2 GHz; 1 V/m, 2 GHz to 2.7 GHz EN61000-4-4:2004 Electrical Fast Transient/Burst (EFT) 1 kV on data cables EN61000-4-6:2009 Conducted immunity requirements, 3 Vrms on data cables 150 kHz to 80 MHz
RoHS (EU Directive 2002/95/EG)	Compliant (as of July 1st, 2006)

Mating Connector Specifications

Table 32 lists the mating connector specifications for the DT9816-OEM module.

Table 32: Mating Connector Specifications for the DT9816-OEM Module

Connector on Module	Mating Connector Specifications
USB Connector	Bulgin part#14193 USB cable
Analog Input Connector (J3)	Tyco part# 1658622-4
Digital I/O Connector (J4)	Tyco part# 1658622-4



Screw Terminal and Connector Pin Assignments and LED Status Indicators

Screw Terminal Assignments	98
DT9816-OEM Connector Pin Assignments	99
LED Status Indicators	101

Screw Terminal Assignments

Table 33 lists the screw terminal assignments for the DT9816, DT9816-A, and DT9816-S modules.

Table 33: Screw Terminal Assignments for the DT9816, DT9816-A, and DT9816-S Modules

Screw Terminal	Signal	Screw Terminal	Signal
20	USB +5 V Out	40	Ext Trigger
19	Ground	39	Ext Clock
18	Counter 0 In	38	Ground
17	Counter 0 Out	37	Digital Output 7
16	Counter 0 Gate	36	Digital Output 6
15	Ground	35	Digital Output 5
14	Reserved	34	Digital Output 4
13	Reserved	33	Digital Output 3
12	Reserved	32	Digital Output 2
11	Reserved	31	Digital Output 1
10	2.5 V Reference	30	Digital Output 0
9	Analog Ground	29	Ground
8	Reserved	28	Digital Input 7
7	Reserved	27	Digital Input 6
6	Analog Input CH5	26	Digital Input 5
5	Analog Input CH4	25	Digital Input 4
4	Analog Input CH3	24	Digital Input 3
3	Analog Input CH2	23	Digital Input 2
2	Analog Input CH1	22	Digital Input 1
1	Analog Input CH0	21	Digital Input 0

DT9816-OEM Connector Pin Assignments

Table 34 lists the pin assignments for the Analog Input connector (J3) on the DT9816-OEM module.

Table 34: Analog Input Connector (J3) Pin Assignments on the DT9816-OEM Module

Pin	Signal	Pin	Signal
20	USB +5 V Out	19	Ground
18	Counter 0 In	17	Counter 0 Out
16	Counter 0 Gate	15	Ground
14	Reserved	13	Reserved
12	Reserved	11	Reserved
10	2.5 V Reference	9	Analog Ground
8	Reserved	7	Reserved
6	Analog Input CH5	5	Analog Input CH4
4	Analog Input CH3	3	Analog Input CH2
2	Analog Input CH1	1	Analog Input CH0

Table 35 lists the pin assignments for the Digital I/O (J4) connector on the DT9816-OEM module.

Table 35: Digital I/O Connector (J4) Pin Assignments on the DT9816-OEM Module

Pin	Signal	Pin	Signal
20	Ext Trigger	19	Ext Clock
18	Ground	17	Digital Output 7
16	Digital Output 6	15	Digital Output 5
14	Digital Output 4	13	Digital Output 3
12	Digital Output 2	11	Digital Output 1
10	Digital Output 0	9	Ground
8	Digital Input 7	7	Digital Input 6
6	Digital Input 5	5	Digital Input 4
4	Digital Input 3	3	Digital Input 2
2	Digital Input 1	1	Digital Input 0

Table 36 lists the pin assignments for the USB 5-pin header on the DT9816-OEM module.

Table 36: USB 5-Pin Header

Pin	Signal
1	+5 V
2	D-
3	D+
4	Ground
5	Shield

LED Status Indicators

The DT9816 Series modules have a single bi-color LED that indicates the status of the module, as described in [Table 37](#).

Table 37: LED Status Indicators on the DT9816 Series Modules

Color of the LED	Status Description
Green	Module is powered
Blinking amber	Module is acquiring data

A

- A/D sample clock
 - external [61](#)
 - internal [60](#)
- A/D subsystem specifications [88](#)
- actual sampling frequency [61](#)
- administrator privileges [30](#)
- aliasing [61](#)
- analog input
 - channel-gain list for analog input channels [60](#)
 - channels [59](#)
 - conversion modes [61](#)
 - data format and transfer [63](#)
 - error conditions [63](#)
 - gain [60](#)
 - ranges [60](#)
 - resolution [59](#)
 - sample clock sources [60](#)
 - single-ended operations [62](#)
 - testing [48](#), [49](#)
 - triggers [63](#)
 - wiring [38](#)
- Analog Input connector pin assignments,
DT9816-OEM [36](#), [37](#), [99](#)
- applet, Open Layers Control Panel [83](#)
- application wiring
 - analog inputs [38](#)
 - digital inputs and outputs [39](#)
 - digital outputs [40](#)
 - event counting [41](#)
 - frequency measurement [42](#)
 - pulse output [43](#)
- applications
 - Quick Data Acq [16](#)
 - QuickDAQ [16](#)
- attaching the module to the computer [27](#)

B

- base clock frequency [78](#)
 - analog input subsystem [61](#)
- BaseClockFrequency [78](#)
- binary data encoding [72](#)
- buffers [72](#)
 - inprocess flush [72](#)

C

- C/C++ programs [18](#)
- C/T, *see* counter/timer [91](#)
- cables, USB [27](#), [28](#)
- CGL, *see* channel-gain list [73](#)
- CGLDepth [73](#)
- changing the name of a module [30](#)
- channel type
 - differential [73](#)
 - single-ended [73](#)
- channel-gain list
 - depth [73](#)
 - for analog input channels [60](#)
- channels
 - analog input [59](#)
 - counter/timer [65](#)
 - digital I/O [64](#)
 - number of [73](#)
- clock sources
 - analog input [60](#)
 - counter/timer [66](#)
- clocks
 - base frequency [78](#)
 - external [78](#)
 - external A/D sample clock [61](#)
 - internal [78](#)
 - internal A/D sample clock [60](#)
 - maximum external clock divider [78](#)
 - maximum throughput [78](#)
 - minimum external clock divider [78](#)
 - minimum throughput [78](#)
 - simultaneous [78](#)
 - specifications [93](#)
- configuring the device driver [30](#)
- connecting signals
 - analog inputs [38](#)
 - digital inputs and outputs [39](#)
 - digital outputs [40](#)
 - event counting [41](#)
 - frequency measurement [42](#)
 - pulse output [43](#)
- connecting to the host computer [27](#)
 - using an expansion hub [28](#)
- connector J1 pin assignments [101](#)
- connector pin assignments, DT9816-OEM [99](#)

- continuous analog input 71
 - scan operations 62
- continuous counter/timer 71
- Control Panel applet 83
- conversion modes
 - continuous analog input (scan mode) 62
 - digital I/O 64
 - single-value analog input 62
- conversion rate 62
- counter/timer
 - channels 65, 73
 - clock sources 66, 78
 - connecting event counting signals 41
 - connecting frequency measurement signals 42
 - connecting pulse output signals 43
 - event counting 79
 - gate types 66
 - high-level gate type 79
 - high-to-low output pulse 79
 - internal gate type 79
 - interrupt-driven operations 80
 - rate generation mode 79
 - subsystem specifications 91
 - variable pulse width 79
- counting events 67
- customer service 85

D

- DAQ Adaptor 18
- DAQ Adaptor for MATLAB 18
- data encoding 72
- data flow modes
 - continuous analog input 71
 - continuous C/T 71
 - single-value 71
- data format and transfer 63
- DataAcq SDK 18
- device driver 16
 - configuring 30
- differential channels 73
- digital I/O
 - lines 64
 - operation modes 64
 - resolution 64
 - subsystem specifications 90
 - testing 50, 51
 - wiring 39, 40
- Digital I/O connector pin assignments,
 - DT9816-OEM 36, 37, 99
- digital trigger 63

- DT9816 Device Driver 16
- DT9816-OEM, layout 36
- DT-Open Layers for .NET Class Library 17
- duty cycle 66

E

- environmental specifications 94
- errors, analog input 63
- event counting 67, 79
 - wiring 41
- external clock 66, 78
 - A/D sample 61
- external clock divider
 - maximum 78
 - minimum 78
- external digital trigger 63
 - negative TTL 77
 - positive TTL 77

F

- factory service 85
- features 14
- formatting data, analog input 63
- frequency
 - base clock 78
 - external A/D sample clock 61
 - internal A/D clock 60, 78
 - internal A/D sample clock 78
 - internal C/T clock 66, 78
 - internal retrigger clock 72
- frequency measurement 42, 52, 67

G

- gain
 - actual available 73
 - analog input 60
 - number of 73
 - programmable 73
- gate type 66
 - high-level 79
 - internal 79
- generating pulses 68

H

- hardware features 14
- header, USB connector 100
- help, online 47

high-level gate type [79](#)
hot-swapping [27](#)

I

inprocess buffers [72](#)
input
 channels [59](#)
 ranges [60](#)
 sample clock sources [60](#)
installing the Quick Data Acq application [47](#)
internal
 clock [66](#), [78](#)
 gate type [79](#)
internal clock [60](#)
internal clock divider
 analog input subsystem [61](#)
interrupt-driven operations [80](#)

J

J1 connector pin assignments [101](#)

L

LabVIEW [18](#)
layout of DT9816-OEM module [36](#)
LED status indicator [101](#)
LEDs [28](#), [29](#)
legacy CPL elevated [30](#)
LV-Link [18](#)

M

mating connector specifications [96](#)
MATLAB [18](#)
MaxDifferentialChannels [73](#)
MaxExtClockDivider [78](#)
MaxFrequency [78](#)
MaxMultiScanCount [72](#)
MaxRetriggerFreq [72](#)
MaxSingleEndedChannels [73](#)
measuring frequency [67](#)
MinExtClockDivider [78](#)
MinFrequency [78](#)
MinRetriggerFreq [72](#)
multiple channels, analog input [60](#)

N

number of
 differential channels [73](#)
 gains [73](#)
 I/O channels [73](#)
 resolutions [74](#)
 scans per trigger [72](#)
 single-ended channels [73](#)
 voltage ranges [74](#)
NumberOfChannels [73](#)
NumberOfRanges [74](#)
NumberOfResolutions [74](#)
NumberOfSupportedGains [73](#)
Nyquist Theorem [61](#)

O

online help [47](#)
Open Layers Control panel [30](#)
Open Layers Control Panel applet [83](#)
operation modes
 continuous analog input (scan mode) [62](#)
 single-value analog input [62](#)
 single-value digital I/O [64](#)
output pulse [79](#)
 generating [68](#)
 wiring [43](#)
output pulses [53](#)

P

physical specifications [94](#)
pin assignments [101](#)
pin assignments, DT9816-OEM [99](#)
power specifications [94](#)
preparing to wire signals [33](#)
pulse output
 rate generation [68](#)
 testing [53](#)
 types [66](#)
 wiring [43](#)
pulse width [66](#)

Q

Quick Data Acq application [16](#)
 installing [47](#)
 running [47](#)

QuickDAQ
Advanced FFT Analysis option 17
Base version 16
FFT Analysis option 16

R

ranges
analog input 60
number of 74
rate generation 68, 79
recommendations for wiring 33
resolution 64
analog input 59
available 74
number of 74
retrigger clock frequency 72
returning modules to the factory 85
RMA 85
running the Quick Data Acq application 47

S

sample clock
external A/D 61
internal A/D 60
sample clock sources 60
sample rate 62
screw terminal assignments, DT9816, DT9816-A,
and DT9816-S 98
SDK 18
service and support procedure 84
simultaneous clocking 78
simultaneous sample-and-hold support 73
single channel, analog input 59
single-ended channels 73
number of 73
single-value operations 71
analog input 62
digital I/O 64
software trigger 63, 77
specifications 87
analog input 88
clocks 93
counter/timer specifications 91
digital I/O 90
environmental 94
mating connector 96
physical 94
power 94
regulatory 95

triggers 92
SupportedGains 73
SupportedResolutions 74
SupportedVoltageRanges 74
SupportsBinaryEncoding 72
SupportsBuffering 72
SupportsContinuous 71
SupportsCount 79
SupportsDifferential 73
SupportsExternalClock 78
SupportsGateHighLevel 79
SupportsGateNone 79
SupportsHighToLowPulse 79
SupportsInProcessFlush 72
SupportsInternalClock 78
SupportsInterrupt 80
SupportsNegExternalTTLTrigger 77
SupportsPosExternalTTLTrigger 77
SupportsProgrammableGain 73
SupportsRateGenerate 79
SupportsSimultaneousClocking 78
SupportsSimultaneousSampleHold 73
SupportsSingleEnded 73
SupportsSingleValue 71
SupportsSoftwareTrigger 77
SupportsVariablePulseWidth 79
system requirements 26

T

technical support 84
throughput
maximum 78
minimum 78
transferring data 63
triggered scan
number of scans per trigger 72
retrigger frequency 72
triggers
analog input 63
external negative digital 63, 77
external positive digital 77
software 63, 77
specifications 92
troubleshooting
procedure 82
service and support procedure 84
troubleshooting table 82
TTL trigger 63

U

units, counter/timer [65](#)
unpacking [25](#)
USB 5-pin header [100](#)
USB cable [27](#), [28](#)

V

variable pulse width [79](#)
Visual Basic for .NET programs [17](#)
Visual C# programs [17](#)
voltage ranges [60](#), [74](#)
 number of [74](#)

W

wiring signals
 analog inputs [38](#)
 digital inputs and outputs [39](#)
 digital outputs [40](#)
 event counting [41](#)
 frequency measurement [42](#)
 methods [36](#)
 preparing [33](#)
 pulse output [43](#)
 recommendations [33](#)
 to the DT9816, DT9816-A, or DT9816-S [33](#)
 to the DT9816-OEM [36](#)
writing programs in
 C/C++ [18](#)
 Visual Basic .NET [17](#)
 Visual C# [17](#)

