



Programming Reference Guide
CIFX API

Hilscher Gesellschaft für Systemautomation mbH

www.hilscher.com

DOC121201PR04EN | Revision 4 | English | 2015-07 | Released | Public

Table of Contents

1	Introduction.....	4
1.1	About this Document.....	4
1.2	List of Revisions.....	4
1.3	Terms, Abbreviations and Definitions.....	5
1.4	References to Documents.....	5
2	Application Note.....	6
2.1	Component Overview for Host Applications.....	6
2.2	Component Overview for netX Applications.....	7
2.3	Availability of API Functions.....	8
3	API Basics.....	11
3.1	DPM Layout, Devices and Channels.....	12
3.2	Basic Fieldbus Data Handling.....	13
3.3	Fieldbus Specific Information and Functions.....	13
4	CIFX API (Application Programming Interface).....	14
4.1	API Header Files.....	14
4.2	Driver Functions.....	14
4.3	System Device Functions.....	15
4.4	Communication Channel Functions.....	16
4.5	Structure Definitions.....	18
4.5.1	Driver Information.....	18
4.5.2	Board Information.....	18
4.5.3	System Channel Information.....	19
4.5.4	Communication Channel Information.....	21
4.6	Driver Related Functions.....	22
4.6.1	xDriverOpen.....	22
4.6.2	xDriverClose.....	23
4.6.3	xDriverGetInformation.....	24
4.6.4	xDriverGetErrorDescription.....	25
4.6.5	xDriverEnumBoards.....	26
4.6.6	xDriverEnumChannels.....	27
4.6.7	xDriverRestartDevice.....	28
4.6.8	xDriverMemoryPointer.....	29
4.7	System Device Specific Functions.....	31
4.7.1	xSysdeviceOpen.....	31
4.7.2	xSysdeviceClose.....	32
4.7.3	xSysdeviceInfo.....	33
4.7.4	xSysdeviceReset.....	34
4.7.5	xSysdeviceBootstart.....	35
4.7.6	xSysdeviceGetMBXState.....	36
4.7.7	xSysdevicePutPacket.....	37
4.7.8	xSysdeviceGetPacket.....	38
4.7.9	xSysdeviceDownload.....	39
4.7.10	xSysdeviceFindFirstFile.....	40
4.7.11	xSysdeviceFindNextFile.....	41
4.7.12	xSysdeviceUpload.....	42
4.7.13	xSysdeviceExtendedMemory.....	43
4.8	Channel Specific Functions.....	47
4.8.1	xChannelOpen.....	47
4.8.2	xChannelClose.....	48
4.8.3	xChannelDownload.....	49
4.8.4	xChannelFindFirstFile.....	50
4.8.5	xChannelFindNextFile.....	51
4.8.6	xChannelUpload.....	52
4.8.7	xChannelGetMBXState.....	53
4.8.8	xChannelPutPacket.....	54
4.8.9	xChannelGetPacket.....	55
4.8.10	xChannelGetSendPacket.....	56
4.8.11	xChannelReset.....	57
4.8.12	xChannelInfo.....	58
4.8.13	xChannelIOInfo.....	59

4.8.14	xChannelWatchdog	60
4.8.15	xChannelConfigLock	61
4.8.16	xChannelHostState.....	62
4.8.17	xChannelBusState.....	63
4.8.18	xChannelControlBlock.....	64
4.8.19	xChannelCommonStatusBlock.....	65
4.8.20	xChannelExtendedStatusBlock	66
4.8.21	xChannelUserBlock.....	67
4.8.22	xChannelIORead.....	68
4.8.23	xChannelIOWrite	69
4.8.24	xChannelIOReadSendData	70
4.8.25	PLC I/O Image Functions	71
4.8.26	DMA Functions.....	80
4.8.27	Notification Functions	81
4.8.28	Fieldbus Synchronization Handling	90
5	Simple C-Application Example	93
5.1	The Main() Function	93
5.2	System Device Example	94
5.3	Communication Channel Example.....	96
5.4	Board and Channel Enumeration.....	100
6	General Protocol Stack Handling	101
6.1	Overview	101
6.2	Protocol Stack Configuration.....	104
6.3	Cyclic Data Exchange	106
7	Error Codes.....	107
8	Appendix	112
8.1	List of Tables	112
8.2	List of Figures.....	112
8.3	Contacts	113

1 Introduction

1.1 About this Document

This manual describes the *CIFX/COMX/netX Application Programming Interface (CIFX API)* and the containing functions, offered for all Hilscher standard devices based on netX controller hardware.

Aim of the API is to provide applications a target and fieldbus independent programming interface to netX based hardware running a standard Hilscher fieldbus protocol or firmware which meet the Hilscher netX dual port memory (netX DPM) definitions, described in the '*netX Dual Port Memory Interface*' manual (see reference [1]).

The API is designed to give the user easy access to all of the communication board functionalities.

In addition, Hilscher also offers a free of charge *cifX Toolkit* (C-source code based) which allows to write own drivers based on the Hilscher netX DPM definitions including the *CIFX API* functions (the toolkit is described in a separate *cifX/netX Toolkit* manual, see reference [2]).

1.2 List of Revisions

Rev	Date	Name	Chapter	Revision
1	2012-12-11	RM	all	Extracted from the CIFX Device Driver - Windows DRV 21 EN.pdf
2	2013-02-18	RM	4.8.28 7	Section <i>Fieldbus Synchronization Handling</i> added. Tables in chapter <i>Error Codes</i> revised.
3	2014-10-08	RM SS RM	4.8.17 4.8.27	Note for xSysdeviceDownload and xChannelDownload inserted. Description of xChannelBusState extended. Description for <i>Notification Functions</i> added.
4	2015-07-25	RM	4.5.3 4.8.22 / 4.8.23 4.8.25	Some writings fixed. SYSTEM_CHANNEL_SYSTEM_STATUS_BLOCK structure updated. note of the default xChannelIORead()/xChannelIOWrite handling added Description of the PLC I/O image functions updated.

Table 1: List of Revisions

1.3 Terms, Abbreviations and Definitions

Term	Description
netX	Hilscher highly integrated network controller
rcX	Hilscher R eal Time C ommunication System for netX
cifX	C ommunication I nterface based on netX
comX	C ommunication M odule based on netX
API	A pplication P rogramming I nterface
DPM	D ual- P ort M emory Physical memory area, connected to a host processor. Standard interface to Hilscher communication boards like CIFX/COMX or netX evaluation boards (Attention: DPM may also be used as a shortcut for PROFIBUS- DP Master field bus protocol).
SHM	S hared M emory System memory area shared between different processes inside a software application
SPI	S erial P eripheral I nterface
RPC	R emote P rocedure C alls
DPM Manual	Description of the standard Hilscher DPM layout and functionality
netX Transport	Diagnostics and remote access functions to netX based remote devices via serial interfaces
CIFX Toolkit	C source-code based implementation of the standard Hilscher DPM access functions
SDO	S ervice D ata O bject
PDO	P rocess D ata O bject

Table 2: Terms, Abbreviations and Definitions

1.4 References to Documents

This document refers to the following documents:

- [1] Hilscher Gesellschaft für Systemautomation mbH: DPM Manual, netX Dual-Port Memory Interface DPM Manual, Revision 12, English, 2012.
Description of the standard Hilscher DPM layout and functionality
- [2] Hilscher Gesellschaft für Systemautomation mbH: Toolkit Manual, cifX/netX Toolkit - DPM, Revision 9, English, 2014.
C source-code based implementation of the standard Hilscher DPM access functions
- [3] Hilscher Gesellschaft für Systemautomation mbH: Program Reference Guide, netX Diagnostic and Remote Access, Fundamentals Revision 2, English, 2011.

Hilscher Gesellschaft für Systemautomation mbH: Program Reference Guide, netX Diagnostic and Remote Access, Host Device Revision 3, English, 2013.

Hilscher Gesellschaft für Systemautomation mbH: Program Reference Guide, netX Diagnostic and Remote Access, Target Device Revision 3, English, 2010

Table 3: References to Documents

2 Application Note

2.1 Component Overview for Host Applications

Hilscher offers the *CIFX API* on different platforms and as different applications (DLL / library or C source code). Usually the API comes with an operating system driver or with the CIFX Toolkit.

The use of the API also implies the physical hardware connection to the netX hardware. While a device driver uses memory functions to access the DPM, the toolkit also allows the implementation of alternative hardware access functions like *DPM via SPI* or custom access functions like *DPM via a custom USB protocol*.

The *netX Transport DLL* is a special implementation of the *CIFX API*, including hardware access via serial interfaces (e.g. USB/serial/Ethernet connections). This component is able to convert *CIFX API* function calls either into appropriate packet based commands (rcX packets, described in reference [1]) or into a dedicated binary format which enables the execution of the API functions on a remote system (similar to RPC - remote procedure calls).

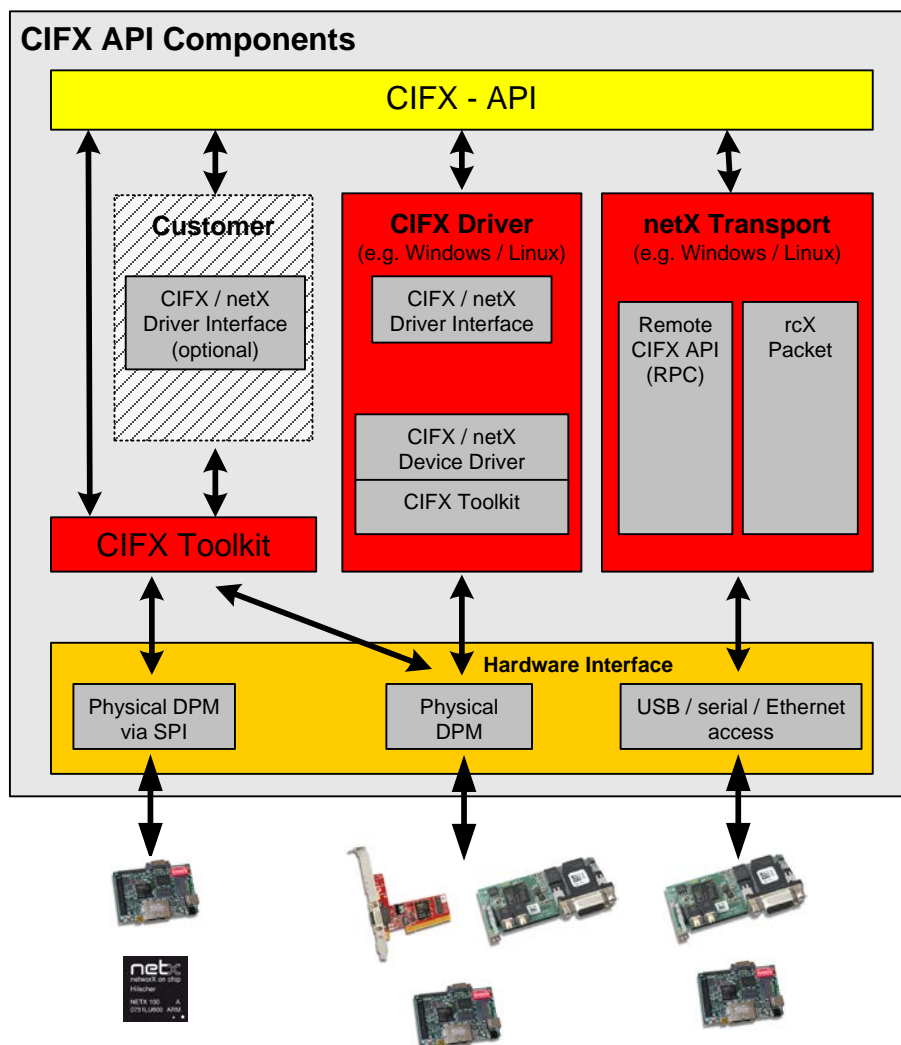

Figure 1: CIFX API Components

NOTE: Not all of the physical connections can be made available on every host system (e.g. SPI on Windows).

- **Physical DPM interface**
The DPM hardware interface, with direct access to the memory, offers the entire defined API functions.
- **Physical DPM via SPI**
The netX hardware offers a SPI interface accepting encoded memory access functions (memory read / write functions) to the DPM. These SPI commands are decoded by the hardware / firmware and executed on the internal DPM of the netX device.
- **USB / serial / Ethernet access**
Another possibility to access a netX device is the use of serial interfaces (USB/serial/Ethernet). In this case, *CIFX API* function calls are converted (described in the *netX Diagnostic and Remote Access* manual, see reference [3]), transferred and processed by the remote netX device.
This type of communication does not offer all of the *CIFX API* functions. Especially functions related to mapped memory areas like *xChannelPLC...()* functions.

2.2 Component Overview for netX Applications

Hilscher also provides the application development directly on the netX communication controller. The *CIFX API* is also available in this environment.

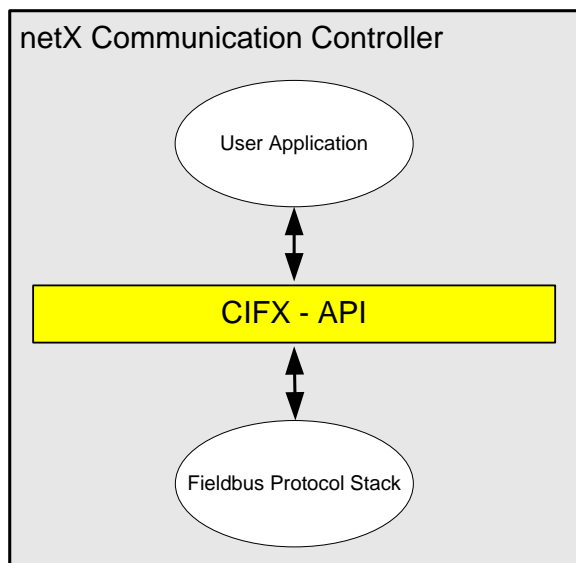

Figure 2: Component Overview for netX Applications

2.3 Availability of API Functions

Following table lists the available API functions regarding to the used environment and the physical hardware connection.

Function	Short Description	DPM	DPM via SPI	USB / serial / Ethernet	netX
				RPC Packet	
xDriverOpen	Opens the driver	X	X	X X	X
xDriverClose	Closes the driver	X	X	X X	X
xDriverGetInformation	Retrieves driver information	X	X	X X	X
xDriverGetErrorDescription	Retrieves an error code description	X	X	X X	X
xDriverEnumBoards	Enumerate available boards/devices	X	X	X X	X
xDriverEnumChannels	Enumerate available channels on a specific board	X	X	X X	X
xDriverRestartDevice	Restart a device	X	X	O O	O
xDriverMemoryPointer	Get/Release a pointer to the dual port memory. Only be used for debugging. purpose	X	O	O O	X

Table 4: List of API Functions – Driver Functions

Function	Short Description	DPM	DPM via SPI	USB / serial / Ethernet	netX
				RPC Packet	
xSysdeviceOpen	Opens a connection a system device	X	X	X X	X
xSysdeviceClose	Closes a connection to a system device	X	X	X X	X
xSysdeviceInfo	Get System device information	X	X	X X	X
xSysdeviceReset	Perform a device reset	X	X	X X	X(3)
xSysdeviceBootstart	Perform a device boot start	X	X	O O	O
xSysdeviceGetMBXState	Retrieves the system mailbox state	X	X	X X	X
xSysdeviceGetPacket	Read a pending packet	X	X	X X	X
xSysdevicePutPacket	Send a packet	X	X	X X	X
xSysdeviceDownload	Downloads a file/configuration/firmware	X	X	X X	X
xSysdeviceFindFirstFile	Find the first file in the given directory	X	X	X X	X
xSysdeviceFindNextFile	Find the next file entry in the given directory	X	X	X X	X
xSysdeviceUpload	Uploads a file/configuration/firmware	X	X	X X	X
xSysdeviceExtendedMemory	Get a pointer an extended memory area	X(1)	O	O O	O

Table 5: List of API Functions – System Device Functions

Function	Short Description	DPM	DPM via SPI	USB / serial / Ethernet	netX
				RPC Packet	
xChannelOpen	Opens a communication channel	X	X	X X	X
xChannelClose	Closes a communication channel	X	X	X X	X
Asynchronous services (Packets)					X
xChannelGetMBXState	Retrieve the channels mailbox state	X	X	X X	X
xChannelGetPacket	Read packet from the channel mailbox	X	X	X X	X
xChannelPutPacket	Send a packet to the channel mailbox	X	X	X X	X
xChannelGetSendPacket	Read back the packet sent	X	X	X O	X
Device Administrational/Informational functions					X
xChannelDownload	Download a file/configuration to the channel	X	X	X X	X
xChannelReset	Reset the channel	X	X	X X	X(4)
xChannelInfo	Retrieve channel specific information	X	X	X O	X
xChannelWatchdog	Activate/Deactivate/Trigger Watchdog	X	X	X O	X
xChannelHostState	Set the Application state flag (signal application is running or not)	X	X	X O	X
xChannelBusState	Set the bus state flag (start or stop fieldbus communication)	X	X	X X	X
xChannelControlBlock	Access the Channels control block	X	X	X X	X
xChannelCommonStatusBlock	Access to the common status block	X	X	X X	X
xChannelExtendedStatusBlock	Access to the extended status block	X	X	X X	X
xChannelUserBlock	Access user block (not implemented yet!)	X	X	X X	X
Cyclic Data services (I/O's)					
xChannelIORead	Instructs the device to place the latest data into the DPM and passes them to the user	X	X	X O	X
xChannelIOWrite	Copies the data to the DPM and waits for the firmware to retrieve them	X	X	X O	X
xChannelIOReadSendData	Reads back the last send data	X	X	X O	X
Cyclic Data services (I/O's, PLC optimized)					
xChannelPLCMemoryPtr	Get a pointer to the IO Block	X	O(2)	O O	X
xChannelPLCActivateRead	Instruct the firmware to place the latest input data into the dual port (no wait for completion)	X	O(2)	O O	X
xChannelPLCActivateWrite	Instruct the firmware to retrieve the latest output data from the dual port (no wait for completion)	X	O(2)	O O	X
xChannelPLCIsReadReady	Checks if the last Read Activation has finished	X	O(2)	O O	X
xChannelPLCIsWriteReady	Checks if the last Write Activation has finished	X	O(2)	O O	X

Function	Short Description	DPM	DPM via SPI	USB / serial / Ethernet	netX
				RPC Packet	
DMA services					
xChannelDMAState	Activate/Deactivate DMA mode	X(1)	O	O O	O
Bus synchronous operation					
xChannelSyncState	Wait for a synchronization event or trigger/acknowledge a sync event	X	O	O O	O
Notification services (only available in Interrupt mode)					
xChannelRegisterNotification	Register a notification callback	X	O	O O	O
xChannelUnregisterNotification	Un-register a notification callback	X	O	O O	O

Table 6: List of API Functions – Communication Channel Functions

- (1) PCI / PCIe hardware only
- (2) Special implementation necessary
- (3) A system reset will reset the whole device. Boot start is not implemented.
- (4) A system reset will reset the whole device

3 API Basics

As described before, the *CIFX API* is the common, fieldbus protocol independent, function interface to Hilscher CIFX/COMX and netX based devices.

It is based on the Hilscher netX DPM (dual-port memory) definition and abstracts the access to the netX based hardware and the Hilscher netX protocol firmware running on the netX.

The API offers a set of functions grouped into '*Driver*' related, '*System Device*' related and '*Communication Channel*' related functions.

Each of the group covers device specific functions by providing a set of API functions necessary for the specific handling.

Functional Groups in the CIFX-API:

- *Driver* related functions
Administration of multiple devices in a standardized way
- *System Device* related functions
General device functions (e.g. system reset, download, device information)
- *Communication Channel* related functions
Fieldbus protocol stack handling

3.1 DPM Layout, Devices and Channels

The DPM layout divides the interface to a netX device into several areas (channels) where each channel has its own structure, predefined information and functionality and can be handled independently from other channels.

A standard netX firmware offers up to 8 channels with three different channel definitions.

General DPM Layout:

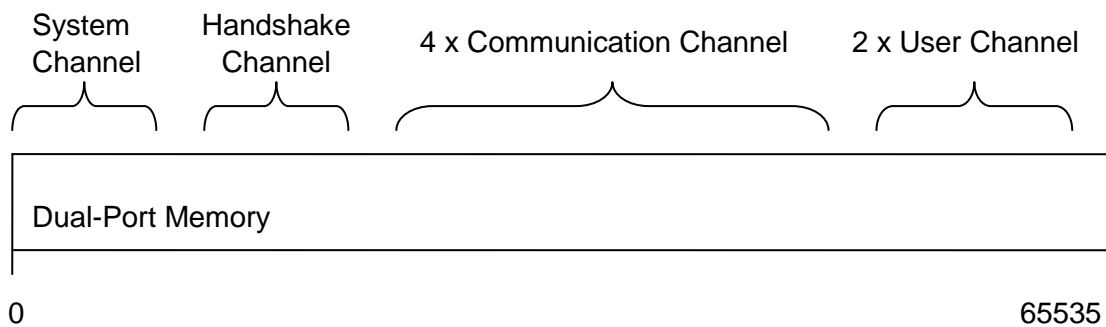

Channel Definition:

- **System Channel** (also named *System Device*)
The main channel is the '*System Channel*' also named '*System Device*'. It is always available and used for administration functions belonging to the whole device, like hardware reset, firmware download etc.
- **Communication Channels**
Communication channels representing a fieldbus connection (a fieldbus protocol stack) with its information and functionalities.
Up to four communication channels are possible.
- **User Channels**
User channels are the third type of channels and designed for user applications, running on the netX chip in parallel to fieldbus protocol stack (two user channels are possible).

The *Handshake Channel* is necessary for special device functionalities like interrupt handling and DPM access synchronization and therefore it has no user API functions offering access to this channel.

CIFX API function names correspond to the function groups and channel definitions.

- **xSysdevice.....()** Functions and functionalities corresponding to the system channel functionalities
- **xChannel.....()** Functions and functionalities corresponding communication channel and its needs
- **xDriver.....()** Functions to handle multiple devices in a common way

3.2 Basic Fieldbus Data Handling

NetX devices are providing two basic mechanisms to transfer user data between a fieldbus protocol stack and user applications.

First one is the cyclic process data transfer mechanism (*Transfer of the Process Data Image*) and the second one is the asynchronous data transfer mechanism (*Packet Oriented Data Transfer*).

Other information like configuration, diagnostic and device specific administration functions are also based on the asynchronous data transfer mechanism.

- **Asynchronous Data Transfer (Packet Oriented Data Transfer)**

Data are transferred by using a data structure named rcX packet. Packet transfer between a host system and the cifX hardware takes place via a, so called, mailbox system. This method is used to transfer of SDO, administration, configuration and diagnostic data.

- **Cyclic Process Data Transfer (Process Data Image Transfer)**

Data are located in a process data image. This method is used for I/O based protocols (PDO transfer).

Input and output data are located in separate memory areas which can be handled independently.

Note: A complete description of the fieldbus data handling can be found in the *netX Dual Port Memory Interface* manual

3.3 Fieldbus Specific Information and Functions

Beside the general device data in the DPM each fieldbus protocol stack comes with its own specific data and functions. This specific information can be found in the corresponding protocol API manuals.

Note: Fieldbus specific information and functionalities can be found in the corresponding protocol API manuals (e. g. *PROFIBUS DP Master Protocol API 15 EN.pdf*).

4 CIFX API (Application Programming Interface)

The API offers functions grouped into 'Driver', 'System Channel' and 'Communication Channel' related functions.

4.1 API Header Files

The API comes with a single C header file.

API definition file: `cifXUser.h`

Error definitions: `cifXError.h`

4.2 Driver Functions

The driver related functions are used to handle a driver and offers functions to identify the connected hardware.

Function	Description
xDriverOpen	Opens the driver, allowing access to every driver function
xDriverClose	Closes an open connection to the driver
xDriverGetInformation	Retrieves driver information (e.g. Version)
xDriverGetErrorDescription	Retrieves an English description of a cifX driver error code
xDriverEnumBoards	Enumerate through all boards/devices the driver is managing
xDriverEnumChannels	Enumerate through all channels located on a specific board
xDriverRestartDevice	Restart a device
xDriverMemoryPointer	Get/Release a pointer to the dual port memory. This function should only be used for debugging purpose

Table 7: Driver Functions

4.3 System Device Functions

Each communication board owns a *System Device* allowing generic access to the device. This '*System Device*' only offers a small mailbox and system global status information and should not be used to communicate with a protocol stack directly.

Function	Description
xSysdeviceOpen	Opens a connection to a boards system device
xSysdeviceClose	Closes a connection to a system device
xSysdeviceInfo	Get System device specific information (e.g. mailbox size)
xSysdeviceReset	Perform a device reset
xSysdeviceBootstart	Perform a device boot start. This will activate the 2 nd Stage bootloader. An available firmware will not be started. Note: Only possible on FLASH based devices.
xSysdeviceGetMBXState	Retrieves the system mailbox state
xSysdeviceGetPacket	Retrieves a pending packet from the system mailbox
xSysdevicePutPacket	Send a packet to the system mailbox
xSysdeviceDownload	Downloads a file/configuration/firmware to the device
xSysdeviceFindFirstFile	Find the first file entry in the given directory
xSysdeviceFindNextFile	Find the next file entry in the given directory
xSysdeviceUpload	Uploads a file/configuration/firmware from the device
xSysdeviceExtendedMemory	Get a pointer to an available extended memory area

Table 8: System Device Functions

4.4 Communication Channel Functions

Each protocol stack is represented as a *Communication Channel*.

Communication channels owning a set of functions, allowing every possible interaction with the protocol stack.

The *CIFX API* functions are protocol stack independent and used for all available Hilscher netX based protocol stacks. Only the data content is protocol specific and must be interpreted by the user application.

Communication Channel Functions:

Function	Description
xChannelOpen	Opens a connection to a communication channel
xChannelClose	Closes a connection
Asynchronous services (Packets)	
xChannelGetMBXState	Retrieve the channels mailbox state
xChannelGetPacket	Retrieve a pending packet from the channel mailbox
xChannelPutPacket	Send a packet to the channel mailbox
xChannelGetSendPacket	Read back the last sent packet
Device Administrational/Informational functions	
xChannelDownload	Download a file/configuration to the channel
xChannelReset	Reset the channel
xChannelInfo	Retrieve channel specific information
xChannelWatchdog	Activate/Deactivate/Trigger the channel Watchdog
xChannelHostState	Set the application state flag in the application COS flags, to signal the hardware if an application is running or not
xChannelBusState	Set the bus state flag in the application COS state flags, to start or stop fieldbus communication.
xChannelControlBlock	Access the channel control block
xChannelCommonStatusBlock	Access to the common status block
xChannelExtendedStatusBlock	Access to the extended status block
xChannelUserBlock	Access user block (not implemented yet!)
Cyclic Data services (I/O's)	
xChannelIORead	Instructs the device to place the latest data into the DPM and passes them to the user
xChannelIOWrite	Copies the data to the DPM and waits for the firmware to retrieve them
xChannelIOReadSendData	Reads back the last send data
Cyclic Data services (I/O's, PLC optimized)	
xChannelPLCMemoryPtr	Get a pointer to the I/O memory block
xChannelPLCActivateRead	Instruct the firmware to place the latest input data into the I/O memory block (no wait for completion)
xChannelPLCActivateWrite	Instruct the firmware to retrieve the latest output data from the I/O memory block (no wait for completion)
xChannelPLCIsReadReady	Checks if the last read activation has finished
xChannelPLCIsWriteReady	Checks if the last write activation has finished

Function	Description
DMA services	
xChannelDMAState	Activate/Deactivate DMA mode
Bus synchronous operation	
xChannelSyncState	Wait for synchronization events or trigger / acknowledge a sync event
Notification services (only available in Interrupt mode)	
xChannelRegisterNotification	Register a notification callback
xChannelUnregisterNotification	Un-register a notification callback

Table 9: Communication Channel Functions

4.5 Structure Definitions

Note: All structures are byte packed, for easy portability and data exchange via the DPM.

4.5.1 Driver Information

When querying the driver information the following structure is expected in the function call.

DRIVER_INFORMATION		
Element	Type	Description
abDriverVersion	uint8_t[32]	Human readable driver name and version
ulBoardCnt	uint32_t	Number of handled boards

Table 10: Driver Information Structure

4.5.2 Board Information

The board information structure is used, when enumerating boards.

BOARD_INFORMATION		
Element	Type	Description
lBoardError	uint32_t	Global board error (currently not used always 0)
abBoardName	uint8_t[16]	This is the name of the board which can be used for opening a channel or the system device on it.
abBoardAlias	uint8_t[16]	This is an alternate, user-definable name for the device
ulBoardID	uint32_t	Unique driver created board identifier
ulSystemError	uint32_t	Boot-up/System error, when trying to handle device
ulPhysicalAddress	uint32_t	Physical address of the device's DPM
ullrqNumber	uint32_t	Interrupt number assigned to the device
blrqEnabled	uint32_t	Defines if the interrupt is used by the driver, or if the driver works in polling mode for this device
ulChannelCnt	uint32_t	Number of available channels
ulDpmTotalSize	uint32_t	Total size of the dual port in bytes
tSystemInfo	SYSTEM_CHANNEL_SYSTEM_INFO_BLOCK (see below)	

Table 11: Board Information Structure

4.5.3 System Channel Information

The following structures are returned on calls to `xSysdeviceInfo()` depending on the passed command parameter:

Command: CIFX_INFO_CMD_SYSTEM_INFORMATION

SYSTEM_CHANNEL_SYSTEM_INFORMATION		
Element	Type	Description
ulSystemError	uint32_t	Boot-up/System error, when trying to handle device
ulDpmTotalSize	uint32_t	Total size of the dual port in bytes
ulMBXSize	uint32_t	Size of the system mailbox in bytes
ulDeviceNumber	uint32_t	Device number (as found on the matrix label)
ulSerialNumber	uint32_t	Serial number (as found on the matrix label)
ulOpenCnt	uint32_t	Number of times this device is open

Table 12: System Channel Information

Command: CIFX_INFO_CMD_SYSTEM_INFO_BLOCK

SYSTEM_CHANNEL_SYSTEM_INFO_BLOCK		
Element	Type	Description
abCookie	uint8_t[4]	System channel identifier MUST be "netX"
ulDpmTotalSize	uint32_t	Total size of the dual port in bytes
ulDeviceNumber	uint32_t	Device number (as found on the matrix label)
ulSerialNumber	uint32_t	Serial number (as found on the matrix label)
ausHwOptions	uint16_t[4]	Array of hardware options for all four possible ports of the netX
usManufacturer	uint16_t	Manufacturer ID
usProductionDate	uint16_t	Production date code
ulLicenseFlags1	uint32_t	Hilscher dedicated license flags (e.g. fieldbus license)
ulLicenseFlags2	uint32_t	Hilscher dedicated license flags (e.g. additional information)
usNetxLicenseID	uint16_t	Special netX user license information
usNetxLicenseFlags	uint16_t	Dedicated netX user license information
usDeviceClass	uint16_t	Hardware device class (e.g. CIFX / COMX etc.)
bHwRevision	uint8_t	Hardware revision
bHwCompatibility	uint8_t	Hardware compatibility list
bDevIdNumber	uint8_t	Device identification number (rotary switch)
bReserved	uint8_t	unused/reserved
usReserved	uint16_t	unused/reserved

Table 13: System Channel Info Block

Command: CIFX_INFO_CMD_SYSTEM_CHANNEL_BLOCK

SYSTEM_CHANNEL_CHANNEL_INFO_BLOCK		
Element	Type	Description
abInfoBlock	uint8_t[8][16]	Channel information in the system channel

Table 14: System Channel - Channel Info Block

Area definitions in cifXUser.h:

CIFX_MAX_NUMBER_OF_CHANNEL_DEFINITION = 8

CIFX_SYSTEM_CHANNEL_DEFAULT_INFO_BLOCK_SIZE = 16

Note: To evaluate the content of the *abInfoBlock* array, refer to the netX DPM Interface Manual and the *rcX_User.h*, structure *NETX_CHANNEL_INFO_BLOCK*.

Command: CIFX_INFO_CMD_SYSTEM_CONTROL_BLOCK

SYSTEM_CHANNEL_SYSTEM_CONTROL_BLOCK		
Element	Type	Description
ulSystemCommandCOS	uint32_t	System channel host COS flags
ulReserved	uint32_t	unused/reserved

Table 15: System Channel Control Block

Command: CIFX_INFO_CMD_SYSTEM_STATUS_BLOCK

SYSTEM_CHANNEL_SYSTEM_STATUS_BLOCK		
Element	Type	Description
ulSystemCOS	uint32_t	System channel device COS flags
ulSystemStatus	uint32_t	Actual system state
ulSystemError	uint32_t	Actual system error
ulBootError	uint32_t	Error code from the second stage bootloader (only valid if Cookie="BOOT")
ulTimeSinceStart	uint32_t	Time since system start in seconds
usCpuLoad	uint16_t	CPU load in 0,01% units (10000 => 100%)
usReserved	uint16_t	Reserved for later use
ulHWFeatures	Uint32_t	Information about hardware features (e.g. MRAM / RTC)
abReserved	uint8_t[36]	unused/reserved

Table 16: System Channel Status Block

4.5.4 Communication Channel Information

The following structure is returned on calls to *xChannelInfo()* or when enumerating channels on a Board using *xDriverEnumChannels()*:

CHANNEL_INFORMATION		
Element	Type	Description
abBoardName	uint8_t[16]	This is the name of the board which can be used for opening a channel or the system device on it.
abBoardAlias	uint8_t[16]	This is an alternate, user-definable name for the device
ulDeviceNumber	uint32_t	Device number (as found on the matrix label)
ulSerialNumber	uint32_t	Serial number (as found on the matrix label)
usFWMajor	uint16_t	Major version number of firmware
usFWMinor	uint16_t	Minor version number of firmware
usFWBuild	uint16_t	Build number of firmware
usFWRevision	uint16_t	Revision version number of firmware
bFWNameLength	uint8_t	Length of firmware name
abFWName	uint8_t[63]	Firmware name
usFWYear	uint16_t	Build year of firmware
bFWMonth	uint8_t	Build month of firmware (1..12)
bFWDay	uint8_t	Build day of firmware (1..31)
ulChannelError	uint32_t	Communication channel error from the "Common Status Block"
ulOpenCnt	uint32_t	Number of calls to xChannelOpen for this channel
ulPutPacketCnt	uint32_t	Number of successful transmitted packets
ulGetPacketCnt	uint32_t	Number of successfully received packets
ulMailboxSize	uint32_t	Mailbox size in Bytes
ulIOInAreaCnt	uint32_t	Number of I/O Input areas
ulIOOutAreaCnt	uint32_t	Number of I/O output areas
ulHskSize	uint32_t	RCX_HANDSHAKE_SIZE_8BIT (0x01) or RCX_HANDSHAKE_SIZE_16BIT (0x02)
ulNetxFlags	uint32_t	Actual netX communication flags (usNetxCommFlag)
ulHostFlags	uint32_t	Actual host communication flags (usHostCommFlags)
ulHostCOSFlags	uint32_t	Actual applicaton COS flags (ulApplicationCOS of Control Block)
ulDeviceCOSFlags	uint32_t	Actual communication COS flags (ulCommunicationCOS of Common Status Block)

Table 17: Channel Information Structure

4.6 Driver Related Functions

4.6.1 xDriverOpen

This function opens a connection / handle to the cifX driver.

Function call:

```
int32_t xDriverOpen( CIFXHANDLE* phDriver)
```

Arguments:

Argument	Data type	Description
phDriver	CIFXHANDLE*	returned handle to the driver

Return Values:

CIFX_NO_ERROR if the function succeeds.

If the function fails, a nonzero error code from chapter *Error Codes* from page 107 is returned. You can use the function *xDriverGetErrorDescription()* to get a description of this error.

4.6.2 xDriverClose

This function closes a connection / handle to the cifX driver.

Function call:

```
int32_t xDriverClose( CIFXHANDLE hDriver )
```

Arguments:

Argument	Data type	Description
hDriver	CIFXHANDLE	Handle returned by xDriverOpen

Return Values:

CIFX_NO_ERROR if the function succeeds.

If the function fails, a nonzero error code from chapter *Error Codes* from page 107 is returned. You can use the function *xDriverGetErrorDescription()* to get a description of this error.

4.6.3 xDriverGetInformation

This function retrieves all driver specific information, like version number, build date, etc.

Function call:

```
int32_t xDriverGetInformation( CIFXHANDLE    hDriver
                             uint32_t      ulSize,
                             void*        pvDriverInfo)
```

Arguments:

Argument	Data type	Description
hDriver	CIFXHANDLE	Handle returned by xDriverOpen
ulSize	uint32_t	Size of the passed structure
pvDriverInfo	void*	Pointer to a DRIVER_INFORMATION structure, to place returned values in.

Return Values:

CIFX_NO_ERROR if the function succeeds.

If the function fails, a nonzero error code from chapter *Error Codes* from page 107 is returned. You can use the function *xDriverGetErrorDescription()* to get a description of this error.

Example:

```
DRIVER_INFORMATION tDriverInfo = {0};
int32_t lRet = xDriverGetInformation(NULL, sizeof(tDriverInfo), &tDriverInfo);
if( lRet == CIFX_NO_ERROR)
{
}
}
```

4.6.4 xDriverGetErrorDescription

Look up function for driver errors. The function returns a human-readable error description (English only).

Function call:

```
int32_t xDriverGetErrorDescription( int32_t lError,
                                   char*   szBuffer,
                                   uint32_t ulBufferLen)
```

Arguments:

Argument	Data type	Description
lError	int32_t	Error value returned by any driver function
szBuffer	String	Pointer to a ASCII string buffer, to place returned text in
ulBufferLen	uint32_t	length of the string buffer for returned data

Return Values:

CIFX_NO_ERROR if the function succeeds.

Example:

```
// Read driver error description
char szError[1024] = {0};
xDriverGetErrorDescription( lError, szError, sizeof(szError));
```

4.6.5 xDriverEnumBoards

Enumerate all currently handled boards/cards of the driver.

Function call:

```
int32_t xDriverEnumBoards( CIFXHANDLE    hDriver,
                          uint32_t      ulBoard,
                          uint32_t      ulSize
                          void*         pvBoardInfo)
```

Arguments:

Argument	Data type	Description
hDriver	CIFXHANDLE	Handle to the driver (returned by xDriverOpen)
ulBoard	uint32_t	Board number to return info for. This must be incremented from zero until an error is returned to query all boards
ulSize	uint32_t	length of the Structure passed in pvBoardInfo
pvBoardInfo	void*	Pointer to returned BOARD_INFORMATION structure

Return Values:

CIFX_NO_ERROR if the function succeeds.

If the function fails, a nonzero error code from chapter *Error Codes* from page 107 is returned. You can use the function *xDriverGetErrorDescription()* to get a description of this error.

Example:

```
int32_t lBoardRet;
do {
    BOARD_INFORMATION tBoardInfo = {0};
    lBoardRet = xDriverEnumBoards(NULL, ulBoardIdx++, sizeof(tBoardInfo), &tBoardInfo);

    if(lBoardRet == CIFX_NO_ERROR)
    {
    }
} while(lBoardRet == CIFX_NO_ERROR);
```

4.6.6 xDriverEnumChannels

Enumerate all available channels on a board/card.

Function call:

```
int32_t xDriverEnumChannels(  CIFXHANDLE  hDriver,
                             uint32_t    ulBoard,
                             uint32_t    ulChannel
                             uint32_t    ulSize
                             void*       pvChannelInfo)
```

Arguments:

Argument	Data type	Description
hDriver	CIFXHANDLE	Handle to the driver (returned by xDriverOpen)
ulBoard	uint32_t	Board number to return info for (constant during channel enumeration).
ulChannel	uint32_t	Channel number to enumerate. This must be incremented from zero until an error is returned to query all channels
ulSize	uint32_t	length of the Structure passed in pvBoardInfo
pvChannelInfo	void*	Pointer to returned CHANNEL_INFORMATION structure

Return Values:

CIFX_NO_ERROR if the function succeeds.

If the function fails, a nonzero error code from chapter *Error Codes* from page 107 is returned. You can use the function *xDriverGetErrorDescription()* to get a description of this error.

Example:

```
int32_t lChannelRet;
do {
    CHANNEL_INFORMATION tChannelInfo = {0};
    lChannelRet = xDriverEnumChannels(NULL, ulBoardIdx, ulChannelIdx++,
                                     sizeof(tChannelInfo), &tChannelInfo);
    if(lChannelRet == CIFX_NO_ERROR)
    {
    }
} while(lChannelRet == CIFX_NO_ERROR);
```

4.6.7 xDriverRestartDevice

The function can be used to restart a netX board. The driver processes the same functions like on a power on reset (reset the hardware and download the bootloader, firmware and configuration files etc.).

A restart is necessary on PCI based netX boards if a running firmware should be updated or changed. Because on such boards the firmware is not stored in a FLASH file system and updating the firmware while it is running in RAM is not possible.

On Windows based systems a restart can also be performed using the *Windows Device Manager* to deactivate/activate the board.

Note: A restart is only performed if no application has an open handle to the board or one of its communication channels.

Function call:

```
int32_t APIENTRY xDriverRestartDevice( CIFXHANDLE hDriver,
                                       char*      szBoardName,
                                       void*      pvData);
```

Arguments:

Argument	Data type	Description
hDriver	CIFXHANDLE	Handle to the driver (returned by <i>xDriverOpen</i>)
szBoardName	String	Identifier for the Board. (e.g. "cifX<Board Number>")
pvData	void*	For further extensions can be NULL

Return Values:

CIFX_NO_ERROR if the function succeeds.

If the function fails, a nonzero error code from chapter *Error Codes* from page 107 is returned. You can use the function *xDriverGetErrorDescription()* to get a description of this error.

4.6.8 xDriverMemoryPointer

Return a pointer to the dual port memory of a board/channel. This function should only be used for debugging purposes, because the function only maps the card memory into the processes memory area.

Function call:

```
int32_t xDriverMemoryPointer ( CIFXHANDLE    hDriver,
                              uint32_t      ulBoard,
                              uint32_t      ulCmd,
                              void*         pvMemoryInfo)
```

Arguments:

Argument	Data type	Description
hDriver	CIFXHANDLE	Handle to the driver (returned by xDriverOpen)
ulBoard	uint32_t	Board number to return pointer for.
ulCmd	uint32_t	Maps the dual port memory for direct access from an application 1 = CIFX_MEM_PTR_OPEN Map a user specific memory area 2 = CIFX_MEM_PTR_USR -> not supported Release the dual port pointer (same memory structure MUST be passed) 3 = CIFX_MEM_PTR_CLOSE
pvMemoryInfo	void*	Pointer to returned MEMORY_INFORMATION structure Note: The Parameter ulChannel must be inserted!

Return Values:

CIFX_NO_ERROR if the function succeeds.

If the function fails, a nonzero error code from chapter *Error Codes* from page 107 is returned. You can use the function *xDriverGetErrorDescription()* to get a description of this error.

Description of the MEMORY_INFORMATION Structure:

Value	Data type	Description
pvMemoryID	void*	Identifier of the memory area
ppvMemoryPtr	void**	Memory pointer
pulMemorySize	uint32_t*	Complete size of the mapped memory
ulChannel	uint32_t*	Requested channel number
pulChannelStartOffset	uint32_t*	Start offset of the requested channel
pulChannelSize	uint32_t*	Memory size of the requested channel

MEMORY_INFORMATION Structure:

```

/*****
/*! Memory Information structure
/*****
typedef __CIFX_PACKED_PRE struct MEMORY_INFORMATIONtag
{
    void*          pvMemoryID;          /*!< Identification of the memory area */
    void**         ppvMemoryPtr;        /*!< Memory pointer */
    uint32_t*      pulMemorySize;       /*!< Complete size of the mapped memory */
    uint32_t       ulChannel;           /*!< Requested channel number */
    uint32_t*      pulChannelStartOffset; /*!< Start offset of the requested channel */
    uint32_t*      pulChannelSize;      /*!< Memory size of the requested channel */
} __CIFX_PACKED_POST MEMORY_INFORMATION;

```

Example:

```

//=====
// Test memory pointer
//
//
//=====
void TestMemoryPointer( void)
{
    unsigned char abBuffer[100] = {0};

    // Open channel
    uint32_t      ulMemoryID           = 0;
    unsigned char* pabDPMMemory        = NULL;
    uint32_t      ulMemorySize         = 0;
    uint32_t      ulChannelStartOffset = 0;
    uint32_t      ulChannelSize        = 0;
    long          lRet                  = CIFX_NO_ERROR;

    MEMORY_INFORMATION tMemory = {0};
    tMemory.pvMemoryID        = &ulMemoryID;          // Identification of the memory area
    tMemory.ppvMemoryPtr      = (void**)&pabDPMMemory; // Memory pointer
    tMemory.pulMemorySize     = &ulMemorySize;        // Complete size of the mapped memory
    tMemory.ulChannel         = CIFX_NO_CHANNEL;       // Requested channel number
    tMemory.pulChannelStartOffset = &ulChannelStartOffset; // Start offset of the requested channel
    tMemory.pulChannelSize    = &ulChannelSize;       // Memory size of the requested channel

    // Open a DPM memory pointer
    lRet = xDriverMemoryPointer( NULL, 0, CIFX_MEM_PTR_OPEN, &tMemory);
    if(lRet != CIFX_NO_ERROR)
    {
        // Failed to get the memory mapping
        ShowError( lRet);
    } else
    {
        // We have a memory mapping
        // Read 100 Bytes
        memcpy( abBuffer, pabDPMMemory, sizeof(abBuffer));

        memcpy( pabDPMMemory, abBuffer, sizeof(abBuffer));
    }

    // Return the DPM memory pointer
    lRet = xDriverMemoryPointer( NULL, 0, CIFX_MEM_PTR_CLOSE, &tMemory);
    ShowError( lRet);
}

```

4.7 System Device Specific Functions

The system device is an additional device created by the device driver for each card. The corresponding data area in the DPM is called system channel. All global board information is located in this channel and all functions of the system device are related to the whole card.

For example the processing of a system reset, downloading a channel firmware etc. Downloads are processed via an own mailbox system which is independently from the communication channels.

The device driver uses the system channel for administrative functions (e.g. card start-up) or to process a card reset.

Usually an application has not to work with the system channel as long as it is designed to work with a specific communication channel or fieldbus system.

4.7.1 xSysdeviceOpen

Open a connection to a system device on the passed board.

Function call:

```
int32_t xSysdeviceOpen( CIFXHANDLE hDriver,
                       char*       szBoard,
                       CIFXHANDLE* phSysdevice);
```

Arguments:

Argument	Data type	Description
hDriver	CIFXHANDLE	Handle of the driver
szBoard	String	Identifier for the Board. Can be cifX<Board Number> or the associated alias.
phSysdevice	CIFXHANDLE*	Returned handle to the system device, to be used on all other sysdevice functions

Return Values:

CIFX_NO_ERROR if the function succeeds.

If the function fails, a nonzero error code from chapter *Error Codes* from page 107 is returned. You can use the function *xDriverGetErrorDescription()* to get a description of this error.

4.7.2 xSysdeviceClose

Close a connection to a system device.

Function call:

```
int32_t xSysdeviceClose( CIFXHANDLE hSysdevice)
```

Arguments:

Argument	Data type	Description
hSysdevice	CIFXHANDLE	Handle of the system device that is to be closed.

Return Values:

CIFX_NO_ERROR if the function succeeds.

If the function fails, a nonzero error code from chapter *Error Codes* from page 107 is returned. You can use the function *xDriverGetErrorDescription()* to get a description of this error.

4.7.3 xSysdeviceInfo

Query information about the opened system device.

Function call:

```
int32_t xSysdeviceInfo(  CIFXHANDLE  hSysdevice,
                        uint32_t    ulCmd,
                        uint32_t    ulSize,
                        void*       pvInfo)
```

Arguments:

Argument	Data type	Description
hSysdevice	CIFXHANDLE	Handle of the system device
ulCmd	uint32_t	Available Commands: 1 = CIFX_INFO_CMD_SYSTEM_INFORMATION 2 = CIFX_INFO_CMD_SYSTEM_INFO_BLOCK 3 = CIFX_INFO_CMD_SYSTEM_CHANNEL_BLOCK 4 = CIFX_INFO_CMD_SYSTEM_CONTROL_BLOCK 5 = CIFX_INFO_CMD_SYSTEM_STATUS_BLOCK
ulSize	uint32_t	Size of the passed system info buffer
pvInfo	void*	Pointer to SYSTEM_CHANNEL_INFORMATION structure for returned data

Return Values:

CIFX_NO_ERROR if the function succeeds.

If the function fails, a nonzero error code from chapter *Error Codes* from page 107 is returned. You can use the function *xDriverGetErrorDescription()* to get a description of this error.

4.7.4 xSysdeviceReset

This function performs a firmware restart. Depending on the hardware and the implementation in the firmware, this could be a software restart or a complete hardware reset.

Usually a software reset is performed.

Note: All channels will be reset.

Function call:

```
int32_t xSysdeviceReset( CIFXHANDLE hSysdevice
                        uint32_t ulTimeout)
```

Arguments:

Argument	Data type	Description
hSysdevice	CIFXHANDLE	Handle of the system device
ulTimeout	uint32_t	Timeout in ms to wait for reset to complete

Return Values:

CIFX_NO_ERROR if the function succeeds.

If the function fails, a nonzero error code from chapter *Error Codes* from page 107 is returned. You can use the function *xDriverGetErrorDescription()* to get a description of this error.

4.7.5 xSysdeviceBootstart

Perform a boot start on the hardware. This is necessary if the 2nd Stage Bootloader should be activated while an executable Firmware is available.

Note: All channels will be reset.

Note: This function is only available on so called FLASH based devices where the 2nd Stage Bootloader is stored in the FLASH of the hardware.

Function call:

```
int32_t xSysdeviceBootstart(    CIFXHANDLE hSysdevice
                               uint32_t   ulTimeout)
```

Arguments:

Argument	Data type	Description
hSysdevice	CIFXHANDLE	Handle of the system device
ulTimeout	uint32_t	Timeout in ms to wait for reset to complete

Return Values:

CIFX_NO_ERROR if the function succeeds.

If the function fails, a nonzero error code from chapter *Error Codes* from page 107 is returned. You can use the function *xDriverGetErrorDescription()* to get a description of this error.

4.7.6 xSysdeviceGetMBXState

Retrieve the current load of the system device mailbox. This Function can be used to read the actual state of the channels send and receive mailbox, without accessing the mailbox itself.

Note: Mailboxes are used to pass asynchronous data back and forth between the hardware and the host system. The amount of concurrent active asynchronous commands is limited by the hardware.

Function call:

```
int32_t xSysdeviceGetMBXState( CIFXHANDLE    hSysdevice,
                              uint32_t*    pulRecvPktCount,
                              uint32_t*    pulSendPktCount )
```

Arguments:

Argument	Data type	Description
hSysdevice	CIFXHANDLE	Handle of the system device.
pulRecvPktCount	uint32_t*	Number of packets waiting to be received by Host
pulSendPktCount	uint32_t*	Number of packets the Host is able to send at once.

Return Values:

CIFX_NO_ERROR if the function succeeds.

If the function fails, a nonzero error code from chapter *Error Codes* from page 107 is returned. You can use the function *xDriverGetErrorDescription()* to get a description of this error.

4.7.7 xSysdevicePutPacket

Insert an asynchronous command (packet) into the system device send mailbox to send it to the hardware. This function uses the system device mailbox.

Function call:

```
int32_t xSysdevicePutPacket(    CIFXHANDLE    hSysdevice,
                              CIFX_PACKET*    ptSendPacket,
                              uint32_t    ulTimeout)
```

Arguments:

Argument	Data type	Description
hChannel	CIFXHANDLE	Handle of the system device.
ptSendPacket	CIFX_PACKET*	Packet to be send. Total data length is acquired through the ulLen element inside the structure.
ulTimeout	uint32_t	Time in ms to wait for the mailbox to get free. 0 means, do not wait

Return Values:

CIFX_NO_ERROR if the function succeeds.

If the function fails, a nonzero error code from chapter *Error Codes* from page 107 is returned. You can use the function *xDriverGetErrorDescription()* to get a description of this error.

4.7.8 xSysdeviceGetPacket

Retrieve an already waiting, asynchronous data packet from the system device receive mailbox.

Function call:

```
int32_t xSysdeviceGetPacket(  CIFXHANDLE    hSysdevice,
                             uint32_t             ulSize,
                             CIFX_PACKET*         ptRecvPacket,
                             uint32_t             ulTimeout)
```

Arguments:

Argument	Data type	Description
hSysdevice	CIFXHANDLE	Handle of the system device.
ulSize	uint32_t	Size of the passed receive packet buffer
ptRecvPacket	CIFX_PACKET*	Buffer to returned packet
ulTimeout	uint32_t	Time in ms to wait for a receive message. 0 means, do not wait

Return Values:

CIFX_NO_ERROR if the function succeeds.

If the function fails, a nonzero error code from chapter *Error Codes* from page 107 is returned. You can use the function *xDriverGetErrorDescription()* to get a description of this error.

4.7.9 xSysdeviceDownload

Downloading files to the board via the system device. Due to the limited size of the mailbox these downloads are slower than using the channels mailbox and should only be used if the channel's firmware is not running yet.

Note: **xSysdeviceDownload() is not working if called with *DOWNLOAD_MODE_FIRMWARE*** on so called "**RAM based devices**" like on CIFX PCI/PCIe cards or devices where the firmware is not stored into Flash.

It is not possible to use this function to download a firmware, because of the circumstance that a firmware running in RAM is not able to update itself in RAM at the same time.

Function call:

```
int32_t xSysdeviceDownload(    CIFXHANDLE    hSysdevice,
                               uint32_t           ulChannel
                               uint32_t           ulMode,
                               char*              pszFileName,
                               uint8_t*          pabFileData,
                               uint32_t           ulFileSize,
                               PFN_PROGRESS_CALLBACK pfnCallback,
                               PFN_RECV_PKT_CALLBACK pfnRecvPktCallback,
                               void*             pvUser)
```

Arguments:

Argument	Data type	Description
hChannel	CIFXHANDLE	Handle of the channel, the download is performed on.
ulChannel	uint32_t	Number of the channel, to receive the file
ulMode	uint32_t	Download mode (See DOWNLOAD_MODE_XXX defines)
pszFileName	char*	Short file name of the passed data on the device.
pabFileData	uint8_t*	File data to download.
ulFileSize	uint32_t	Length of the file in bytes
pfnCallback	PFN_PROGRESS_CALLBACK	Callback function to indicate the download progress. Passing NULL will suppress callbacks.
pfnRecvPktCallback	PFN_RECV_PKT_CALLBACK	Callback function to receive unhandled packets during this function. Passing NULL will suppress callbacks and discard received packets that do not belong to the file download.
pvUser	void*	User parameter which is passed on every callback

Return Values:

CIFX_NO_ERROR if the function succeeds.

If the function fails, a nonzero error code from chapter *Error Codes* from page 107 is returned. You can use the function *xDriverGetErrorDescription()* to get a description of this error.

4.7.10 xSysdeviceFindFirstFile

Start enumerating a directory on the device. This call will deliver the first directory/file entry on the device if available.

Function call:

```
int32_t xSysdeviceFindFirstFile(    CIFXHANDLE    hSysdevice,
                                   uint32_t         ulChannel,
                                   CIFX_DIRECTORYENTRY* ptDirectoryInfo,
                                   PFN_RECV_PKT_CALLBACK pfnRecvPktCallback,
                                   void*              pvUser)
```

Arguments:

Argument	Data type	Description
hSysdevice	CIFXHANDLE	Handle of the system device.
ulChannel	uint32_t	Channel number
ptDirectoryInfo	CIFX_DIRECTORYENTRY*	Returned first directory entry. The szFilename entry can be used to start enumerating on a special file. Must be a zero length string to enumerate the whole directory.
pfnRecvPktCallback	PFN_RECV_PKT_CALLBACK	Callback function to receive unhandled packets during this function. Passing NULL will suppress callbacks and discard received packets that do not belong to the file search.
pvUser	void*	User parameter which is passed on every callback

Return Values:

CIFX_NO_ERROR if the function succeeds.

If the function fails, a nonzero error code from chapter *Error Codes* from page 107 is returned. You can use the function *xDriverGetErrorDescription()* to get a description of this error.

4.7.11 xSysdeviceFindNextFile

Continue enumerating a directory on the device. This function must be called with a previously returned directory entry structure from *xSysdeviceFindFirstFile()*.

Function call:

```
int32_t xSysdeviceFindNextFile (    CIFXHANDLE          hSysdevice,
                                   uint32_t                ulChannel,
                                   CIFX_DIRECTORYENTRY*     ptDirectoryInfo,
                                   PFN_RECV_PKT_CALLBACK    pfnRecvPktCallback,
                                   void*                    pvUser)
```

Arguments:

Argument	Data type	Description
hSysdevice	CIFXHANDLE	Handle of the system device.
ulChannel	uint32_t	Channel number
ptDirectoryInfo	CIFX_DIRECTORYENTRY*	Returned directory entry.
pfnRecvPktCallback	PFN_RECV_PKT_CALLBACK	Callback function to receive unhandled packets during this function. Passing NULL will suppress callbacks and discard received packets that do not belong to the file search.
pvUser	void*	User parameter which is passed on every callback

Return Values:

CIFX_NO_ERROR if the function succeeds.

If the function fails, a nonzero error code from chapter *Error Codes* from page 107 is returned. You can use the function *xDriverGetErrorDescription()* to get a description of this error.

4.7.12 xSysdeviceUpload

Upload a given file from the device.

Function call:

```
int32_t xSysdeviceUpload( CIFXHANDLE          hSysdevice,
                          uint32_t          ulChannel,
                          uint32_t          ulMode,
                          char*             pszFilename,
                          uint8_t*         pabFileData,
                          uint32_t*        pulFileSize,
                          PFN_PROGRESS_CALLBACK pfnCallback,
                          PFN_RECV_PKT_CALLBACK pfnRecvPktCallback,
                          void*            pvUser )
```

Arguments:

Argument	Data type	Description
hSysdevice	CIFXHANDLE	Handle of the system device.
ulChannel	uint32_t	Channel number of the file
ulMode	uint32_t	Upload Mode (see DOWNLOAD_MODE_XXX)
pszFilename	char*	Name of the file to upload (must conform to 8.3 filename rules)
pabFileData	uint8_t*	Buffer to place uploaded data in
pulFileSize	uint32_t *	[in] Size of the buffer, [out] Number of uploaded bytes
pfnCallback	PFN_PROGRESS_CALLBACK	Callback function to indicate the download progress. Passing NULL will suppress callbacks.
pfnRecvPktCallback	PFN_RECV_PKT_CALLBACK	Callback function to receive unhandled packets during this function. Passing NULL will suppress callbacks and discard received packets that do not belong to the file upload.
pvUser	void*	User parameter which is passed on every callback

Return Values:

CIFX_NO_ERROR if the function succeeds.

If the function fails, a nonzero error code from chapter *Error Codes* from page 107 is returned. You can use the function *xDriverGetErrorDescription()* to get a description of this error.

4.7.13 xSysdeviceExtendedMemory

netX based PCI hardware is able to offer a second PCI memory window used to access additional hardware memory, independent of the existing Hilscher dual-port-memory resource.

Depending on the netX hardware, the type of memory resource could differ. Current hardware offers a MRAM (Magnetoresistive Random Access Memory) resource.

The type of additional memory, assembled on the hardware, is defined by information in the hardware security memory. The information is used by the bootloader and firmware to detect and initialize access to the additional memory and the information is also stored in the NETX_SYSTEM_STATUS_BLOCK (see *ulHWFeatures*) to be accessible by a user application.

The *xSysdeviceExtendedMemory()* function offers a command parameter to allow reading information and getting/returning the pointer to the extended memory.

Function call:

```
int32_t xSysdeviceExtendedMemory( CIFXHANDLE hSysdevice,
                                  uint32_t ulCmd,
                                  CIFX_EXTENDED_MEMORY_INFORMATION* ptExtMemData );
```

Arguments:

Argument	Data type	Description
hSysdevice	CIFXHANDLE	Handle of the system device.
ulCmd	uint32_t	Extended Memory Commands: 1 = CIFX_GET_EXTENDED_MEMORY_INFO 2 = CIFX_GET_EXTENDED_MEMORY_POINTER 3 = CIFX_FREE_EXTENDED_MEMORY_POINTER
ptExtMemData	CIFX_EXTENDED_MEMORY_INFORMATION*	Pointer to an extended memory structure, to store/pass information between driver and application

Return Values:

CIFX_NO_ERROR if the function succeeds.

If the function fails, a nonzero error code from chapter *Error Codes* from page 107 is returned. You can use the function *xDriverGetErrorDescription()* to get a description of this error.

Description of the CIFX_EXTENDED_MEMORY_INFORMATION Structure:

Value	Data type	Description
pvMemoryID	void*	Identifier of the memory area
pvMemoryPtr	void*	Memory pointer to the extended memory area
ulMemorySize	uint32_t	Size of the extended memory area
ulMemoryType	uint32_t	Type of the extended memory area (e.g. MRAM)

ulMemoryInformation:

								Extended Memory									
31..16	15	14	13	12	11	10	9	8	7	6	5	4	3	2	1	0	
												RAM Type: 0 = None 1 = MRAM 64*16 Bit (1 MBit/128 KB)					
												Reserved					
												Access Type: 00 = No access 01 = external access (host) 10 = internal access 11 = external and internal access reserved					
Unused set to 0																	

Note: *ulMemoryType* defines the type of the assembled/offered memory by the hardware. The type is defined in the hardware security memory.

Available definitions (see rcX_User.h):

```
#define RCX_SYSTEM_EXTMEM_TYPE_MSK          0x0000000F
#define RCX_SYSTEM_EXTMEM_TYPE_NONE        0x00000000
#define RCX_SYSTEM_EXTMEM_TYPE_MRAM_128K  0x00000001

#define RCX_SYSTEM_EXTMEM_ACCESS_MSK       0x000000C0
#define RCX_SYSTEM_EXTMEM_ACCESS_NONE     0x00000000
#define RCX_SYSTEM_EXTMEM_ACCESS_EXTERNAL 0x00000040
#define RCX_SYSTEM_EXTMEM_ACCESS_INTERNAL 0x00000080
#define RCX_SYSTEM_EXTMEM_ACCESS_BOTH     0x000000C0
```

Note: RCX_SYSTEM_EXTMEM_ACCESS_EXTERNAL defines exclusive access by a host application while RCX_SYSTEM_EXTMEM_ACCESS_INTERNAL defines exclusive access by the firmware. RCX_SYSTEM_EXTMEM_ACCESS_BOTH defines access for the firmware and host application. In this case, first half of the memory is reserved for the host application, starting at offset 0 and the second half of the memory is used by the firmware, starting at offset memory size / 2.

CIFX_EXTENDED_MEMORY_INFORMATION structure:

```

/*****
/*! Extended memory information structure */
/*****
typedef __CIFX_PACKED_PRE struct CIFX_EXTENDED_MEMORY_INFORMATIONtag
{
    void*          pvMemoryID;          /*!< Identification of the memory area */
    void*          pvMemoryPtr;         /*!< Memory pointer */
    uint32_t       ulMemorySize;        /*!< Memory size of the Extended memory area */
    uint32_t       ulMemoryType;        /*!< Memory type information */
} __CIFX_PACKED_POST CIFX_EXTENDED_MEMORY_INFORMATION;

```

Example:

```

//=====
// Test memory pointer
//
//
//=====
void TestExtendedMemoryPointer( void)
{
    CIFXHANDLE     hSysdevice    = NULL;
    int32_t        lRet          = CIFX_NO_ERROR;
    uint8_t        abBuffer[100] = {0};

    printf("\n--- Test Extended Memory Pointer ---\r\n");

    lRet = xSysdeviceOpen( NULL, "CIFX0", &hSysdevice);

    if ( CIFX_NO_ERROR != lRet)
    {
        ShowError( lRet);
    } else
    {
        CIFX_EXTENDED_MEMORY_INFORMATION tExtMemory = {0};

        // Open a DPM memory pointer
        lRet = xSysdeviceExtendedMemory( hSysdevice, CIFX_GET_EXTENDED_MEMORY_INFO,
                                         &tExtMemory);

        if(lRet != CIFX_NO_ERROR)
        {
            // Failed to get the memory mapping
            ShowError( lRet);
        } else
        {
            /* Get an extended memory pointer */
            lRet = xSysdeviceExtendedMemory( hSysdevice, CIFX_GET_EXTENDED_MEMORY_POINTER,
                                             &tExtMemory);

            if(lRet != CIFX_NO_ERROR)
            {
                // Failed to get the memory mapping
                ShowError( lRet);
            }else
            {
                // We have a memory mapping
                uint8_t* pbExtMem = (uint8_t*)tExtMemory.pvMemoryPtr;

                while( 1 == 1)
                {
                    // Read 100 Bytes
                    memcpy( abBuffer, pbExtMem, sizeof(abBuffer));

                    printf("Read data from the extended memory (%d bytes):\n",
                           sizeof(abBuffer));
                    DumpData( abBuffer, sizeof(abBuffer));
                }
            }
        }
    }
}

```

```
    printf("Increment the read data:\n");
    for ( uint32_t ulIdx =0; ulIdx < sizeof(abBuffer); ulIdx++)
    {
        abBuffer[ulIdx] +=1;
    }

    printf("Write data back to the extened memory:\n");
    memcpy( pbExtMem, abBuffer, sizeof(abBuffer));

    printf("Type (A) for again and (S) to stop the extended read/write test:\n");
    if( 'S' == (toupper (_getch())) )
    {
        break;
    }
}
lRet = xSysdeviceExtendedMemory( hSysdevice, CIFX_FREE_EXTENDED_MEMORY_POINTER,
                                &tExtMemory);

if(lRet != CIFX_NO_ERROR)
{
    // Failed to free the memory mapping
    ShowError( lRet);
}
}

/* Close the system device */
lRet = xSysdeviceClose( hSysdevice);
if ( CIFX_NO_ERROR != lRet)
{
    ShowError( lRet);
}
}

// Test done
printf("\n Extended Memory Pointer test done\r\n");
}
```

4.8 Channel Specific Functions

Channels (Communication Channels) are the access to a specific fieldbus system running on the netX hardware. Each channel has its own memory area in the DPM and can be handled independently from other channels.

4.8.1 xChannelOpen

Open a connection to a communication / user channel on the given board.

Function call:

```
int32_t xChannelOpen(
    CIFXHANDLE hDriver,
    char*      szBoard,
    uint32_t   ulChannel,
    CIFXHANDLE* phChannel)
```

Arguments:

Argument	Data type	Description
hDriver	CIFXHANDLE	Handle to the driver (returned by xDriverOpen)
szBoard	char*	Identifier for the Board. Can be cifX<BoardNumber> or the associated alias.
ulChannel	uint32_t	Channel number to open
phChannel	CIFXHANDLE*	Returned handle to the channel, to be used on all other channel functions

Return Values:

CIFX_NO_ERROR if the function succeeds.

If the function fails, a nonzero error code from chapter *Error Codes* from page 107 is returned. You can use the function *xDriverGetErrorDescription()* to get a description of this error.

4.8.2 xChannelClose

Close a connection to a communication channel.

Function call:

```
int32_t xChannelClose( CIFXHANDLE hChannel )
```

Arguments:

Argument	Data type	Description
hChannel	CIFXHANDLE	Handle of the channel that is to be closed.

Return Values:

CIFX_NO_ERROR if the function succeeds.

If the function fails, a nonzero error code from chapter *Error Codes* from page 107 is returned. You can use the function *xDriverGetErrorDescription()* to get a description of this error.

4.8.3 xChannelDownload

Download a file to a communication channel.

Note: **xChannelDownload() is not working if called with *DOWNLOAD_MODE_FIRMWARE* on so called "RAM based devices" like on CIFX PCI/PCIe cards or devices where the firmware is not stored into Flash.**

It is not possible to use this function to download a firmware, because of the circumstance that a firmware running in RAM is not able to update itself in RAM at the same time.

Function call:

```
int32_t xChannelDownload( CIFXHANDLE          hChannel,
                          uint32_t          ulMode,
                          char*             pszFileName,
                          uint8_t*         pabFileData,
                          uint32_t         ulFileSize,
                          PFN_PROGRESS_CALLBACK pfnCallback,
                          PFN_RECV_PKT_CALLBACK pfnRecvPktCallback,
                          void*            pvUser)
```

Arguments:

Argument	Data type	Description
hChannel	CIFXHANDLE	Handle of the channel, the download is performed on.
ulMode	uint32_t	Download mode (See <i>DOWNLOAD_MODE_XXX</i> defines)
pszFileName	char*	Short file name of the passed data on the device.
pabFileData	uint8_t*	File data to download.
ulFileSize	uint32_t	Length of the downloaded file
pfnCallback	PFN_PROGRESS_CALLBACK	Callback function to indicate the download progress. Passing NULL will suppress callbacks.
pfnRecvPktCallback	PFN_RECV_PKT_CALLBACK	Callback function to receive unhandled packets during this function. Passing NULL will suppress callbacks and discard all received packets that do not belong to the file download.
pvUser	void*	User parameter which is passed on every callback

Return Values:

CIFX_NO_ERROR if the function succeeds.

If the function fails, a nonzero error code from chapter *Error Codes* from page 107 is returned. You can use the function *xDriverGetErrorDescription()* to get a description of this error.

4.8.4 xChannelFindFirstFile

Start enumerating a directory on the channel. This call will deliver the first directory/file entry on the channel if available.

Function call:

```
int32_t xChannelFindFirstFile ( CIFXHANDLE          hChannel,
                               CIFX_DIRECTORYENTRY* ptDirectoryInfo,
                               PFN_RECV_PKT_CALLBACK pfnRecvPktCallback,
                               void*                pvUser )
```

Arguments:

Argument	Data type	Description
hChannel	CIFXHANDLE	Handle of the communication channel.
ptDirectoryInfo	CIFX_DIRECTORYENTRY*	Returned first directory entry. The szFilename entry can be used to start enumerating on a special file. Must be a zero length string to enumerate the whole directory.
pfnRecvPktCallback	PFN_RECV_PKT_CALLBACK	Callback function to receive unhandled packets during this function. Passing NULL will suppress callbacks and discard all received packets that do not belong to the file find.
pvUser	void*	User parameter which is passed on every callback

Return Values:

CIFX_NO_ERROR if the function succeeds.

If the function fails, a nonzero error code from chapter *Error Codes* from page 107 is returned. You can use the function *xDriverGetErrorDescription()* to get a description of this error.

4.8.5 xChannelFindNextFile

Continue enumerating a directory on the channel. This function must be called with a previously returned directory entry structure from *xChannelFindFirstFile()*.

Function call:

```
int32_t xChannelFindNextFile ( CIFXHANDLE          hChannel,
                              CIFX_DIRECTORYENTRY* ptDirectoryInfo,
                              PFN_RECV_PKT_CALLBACK pfnRecvPktCallback,
                              void*                pvUser )
```

Arguments:

Argument	Data type	Description
hChannel	CIFXHANDLE	Handle of the communication channel.
ptDirectoryInfo	CIFX_DIRECTORYENTRY*	Returned directory entry.
pfnRecvPktCallback	PFN_RECV_PKT_CALLBACK	Callback function to receive unhandled packets during this function. Passing NULL will suppress callbacks and discard all received packets that do not belong to the file find.
pvUser	void*	User parameter which is passed on every callback

Return Values:

CIFX_NO_ERROR if the function succeeds.

If the function fails, a nonzero error code from chapter *Error Codes* from page 107 is returned. You can use the function *xDriverGetErrorDescription()* to get a description of this error.

4.8.6 xChannelUpload

Upload a given file from the communication channel.

Function call:

```
int32_t xChannelUpload (  CIFXHANDLE          hChannel,
                          uint32_t          ulMode,
                          char*             pszFileName,
                          uint8_t*         pabFileData,
                          uint32_t*        pulFileSize,
                          PFN_PROGRESS_CALLBACK pfnCallback,
                          PFN_RECV_PKT_CALLBACK pfnRecvPktCallback,
                          void*            pvUser)
```

Arguments:

Argument	Data type	Description
hChannel	CIFXHANDLE	Handle of the communication channel.
ulMode	uint32_t	Upload Mode (see DOWNLOAD_MODE_XXX)
pszFileName	char*	Name of the file to upload (must conform to 8.3 filename rules)
pabFileData	uint8_t*	Buffer to place uploaded data in
pulFileSize	uint32_t*	[in] Size of the buffer, [out] Number of uploaded bytes
pfnCallback	PFN_PROGRESS_CALLBACK	Callback function to indicate the download progress. Passing NULL will suppress callbacks.
pfnRecvPktCallback	PFN_RECV_PKT_CALLBACK	Callback function to receive unhandled packets during this function. Passing NULL will suppress callbacks and discard all received packets that do not belong to the file upload.
pvUser	void*	User parameter which is passed on every callback

Return Values:

CIFX_NO_ERROR if the function succeeds.

If the function fails, a nonzero error code from chapter *Error Codes* from page 107 is returned. You can use the function *xDriverGetErrorDescription()* to get a description of this error.

4.8.7 xChannelGetMBXState

Retrieve the current load of the given communication channel mailbox. This Function can be used to read the actual state of the channels send and receive mailbox without accessing the mailbox itself.

Note: Mailboxes are used to pass asynchronous data back and forth between the hardware and the host system. The amount of concurrent active asynchronous commands is limited by the hardware.

Function call:

```
int32_t xChannelGetMBXState(  CIFXHANDLE  hChannel,
                             uint32_t*    pulRecvPktCount,
                             uint32_t*    pulSendPktCount)
```

Arguments:

Argument	Data type	Description
hChannel	CIFXHANDLE	Handle of the channel.
pulRecvPktCount	uint32_t*	Number of packets waiting to be received by Host
pulSendPktCount	uint32_t*	Number of packets the Host is able to send at once.

Return Values:

CIFX_NO_ERROR if the function succeeds.

If the function fails, a nonzero error code from chapter *Error Codes* from page 107 is returned. You can use the function *xDriverGetErrorDescription()* to get a description of this error.

4.8.8 xChannelPutPacket

Insert an asynchronous data packet into the given communication channel send mailbox to send it to the hardware.

Function call:

```
int32_t xChannelPutPacket( CIFXHANDLE    hChannel,
                          CIFX_PACKET*  ptSendPacket,
                          uint32_t      ulTimeout)
```

Arguments:

Argument	Data type	Description
hChannel	CIFXHANDLE	Handle of the channel.
ptSendPacket	CIFX_PACKET*	Packet to be send. Total data length is acquired through the ulLen element inside the structure.
ulTimeout	uint32_t	Time in ms to wait for the mailbox to get free. 0 means, do not wait

Return Values:

CIFX_NO_ERROR if the function succeeds.

If the function fails, a nonzero error code from chapter *Error Codes* from page 107 is returned. You can use the function *xDriverGetErrorDescription()* to get a description of this error.

4.8.9 xChannelGetPacket

Retrieve an already waiting, asynchronous data packet from the given communication channel receive mailbox.

Function call:

```
int32_t xChannelGetPacket( CIFXHANDLE    hChannel,
                          uint32_t      ulBufferSize,
                          CIFX_PACKET*  ptRecvPacket,
                          uint32_t      ulTimeout)
```

Arguments:

Argument	Data type	Description
hChannel	CIFXHANDLE	Handle of the channel.
ulBufferSize	uint32_t	Size of the passed receive packet buffer
ptRecvPacket	CIFX_PACKET*	Buffer to returned packet
ulTimeout	uint32_t	Time in ms to wait for a receive message. 0 means, do not wait

Return Values:

CIFX_NO_ERROR if the function succeeds.

If the function fails, a nonzero error code from chapter *Error Codes* from page 107 is returned. You can use the function *xDriverGetErrorDescription()* to get a description of this error.

4.8.10 xChannelGetSendPacket

Retrieve the actual data packet send by the host, from the communication channel send mailbox. This function is none destructive. It does not guarantee any data consistency, because data are read without any synchronization.

The function is mainly used for debugging aids.

Function call:

```
int32_t xChannelGetSendPacket( CIFXHANDLE    hChannel,
                              uint32_t      ulBufferSize,
                              CIFX_PACKET*  ptRecvPacket )
```

Arguments:

Argument	Data type	Description
hChannel	CIFXHANDLE	Handle of the channel.
ulBufferSize	uint32_t	Size of the passed packet buffer
ptRecvPacket	CIFX_PACKET*	Buffer to returned send packet

Return Values:

CIFX_NO_ERROR if the function succeeds.

If the function fails, a nonzero error code from chapter *Error Codes* from page 107 is returned. You can use the function *xDriverGetErrorDescription()* to get a description of this error.

4.8.11 xChannelReset

Reset the given communication channel. The reset function offers a following two modes:

- CIFX_CHANNELINIT Re-initialization of a communication channel
- CIFX_SYSTEMSTART Restart the whole card

Function call:

```
int32_t xChannelReset(      CIFXHANDLE      hChannel,
                            uint32_t            ulResetMode,
                            uint32_t            ulTimeout)
```

Arguments:

Argument	Data type	Description
hChannel	CIFXHANDLE	Handle of the channel.
ulResetMode	uint32_t	Type of reset to be performed
ulTimeout	uint32_t	Time in ms to wait for the channel to be ready again

Return Values:

CIFX_NO_ERROR if the function succeeds.

If the function fails, a nonzero error code from chapter *Error Codes* from page 107 is returned. You can use the function *xDriverGetErrorDescription()* to get a description of this error.

4.8.12 xChannelInfo

Retrieve the global communication channel information.

Function call:

```
int32_t xChannelInfo(    CIFXHANDLE    hChannel,
                        uint32_t    ulSize,
                        void*        pvChannelInfo)
```

Arguments:

Argument	Data type	Description
hChannel	CIFXHANDLE	Handle of the channel.
ulSize	uint32_t	Length of the passed buffer.
pvChannelInfo	void*	Pointer to a CHANNEL_INFORMATION structure, for returned data

Return Values:

CIFX_NO_ERROR if the function succeeds.

If the function fails, a nonzero error code from chapter *Error Codes* from page 107 is returned. You can use the function *xDriverGetErrorDescription()* to get a description of this error.

4.8.13 xChannelIOInfo

Retrieve I/O information about the communication channel.

Function call:

```
int32_t xChannelIOInfo(  CIFXHANDLE  hChannel,
                        uint32_t    ulCmd,
                        uint32_t    ulAreaNumber,
                        uint32_t    ulSize,
                        void*       pvData)
```

Arguments:

Argument	Data type	Description
hChannel	CIFXHANDLE	Handle of the channel.
ulCmd	uint32_t	1 = CIFX_IO_INPUT_AREA 2 = CIFX_IO_OUTPUT_AREA
ulAreaNumber	uint32_t	Area number to query information for
ulSize	uint32_t	Length of the passed buffer.
pvData	void*	Pointer to a CHANNEL_IO_INFORMATION structure, for returned data

Return Values:

CIFX_NO_ERROR if the function succeeds.

If the function fails, a nonzero error code from chapter *Error Codes* from page 107 is returned. You can use the function *xDriverGetErrorDescription()* to get a description of this error.

4.8.14 xChannelWatchdog

Enable, trigger or disable the host watchdog. The watchdog function is used by a communication channel to supervise the processing of the user application. If the watchdog is configured it will be activated with the first call of the function `xChannelWatchdog()` passing the command `CIFX_WATCHDOG_START`. Once activated, the application must trigger it cyclically, during the configured watchdog time. The watchdog supervision is deactivated by passing `CIFX_WATCHDOG_STOP` in the call of `xChannelWatchdog()`.

Function call:

```
int32_t xChannelWatchdog( CIFXHANDLE    hChannel,
                          uint32_t     ulCmd,
                          uint32_t*    pulTrigger)
```

Arguments:

Argument	Data type	Description
hChannel	CIFXHANDLE	Handle of the channel.
ulCmd	uint32_t	Watchdog Command Start and trigger the watchdog monitoring 1 = CIFX_WATCHDOG_START Stop the watchdog monitoring 0 = CIFX_WATCHDOG_STOP
pulTrigger	uint32_t*	Last trigger value from the hardware

Return Values:

`CIFX_NO_ERROR` if the function succeeds.

If the function fails, a nonzero error code from chapter *Error Codes* from page 107 is returned. You can use the function `xDriverGetErrorDescription()` to get a description of this error.

4.8.15 xChannelConfigLock

Lock the configuration of the channel against modification. If the configuration is locked, the fieldbus stack does not allow doing a configuration update.

Function call:

```
int32_t xChannelConfigLock(    CIFXHANDLE    hChannel,
                              uint32_t          ulCmd,
                              uint32_t*         pulState,
                              uint32_t          ulTimeout)
```

Arguments:

Argument	Data type	Description
hChannel	CIFXHANDLE	Handle of the channel.
ulCmd	uint32_t	Configuration Lock Command Unlock configuration 0 = CIFX_CONFIGURATION_UNLOCK Lock configuration 1 = CIFX_CONFIGURATION_LOCK Read the locking state 2 = CIFX_CONFIGURATION_GETLOCKSTATE
pulState	uint32_t*	returned state, if the CIFX_CONFIGURATION_GETLOCKSTATE command is used
ulTimeout	uint32_t	Timeout in ms to wait for configuration lock becoming active

Return Values:

CIFX_NO_ERROR if the function succeeds.

If the function fails, a nonzero error code from chapter *Error Codes* from page 107 is returned. You can use the function *xDriverGetErrorDescription()* to get a description of this error.

4.8.16 xChannelHostState

Toggle the '*Application Ready State Flag*' in the communication channel host handshake flags. This function is used to signal a communication stack the presents of a user application.

How the fieldbus stack uses the information is stack depending. Usually the stack will use the information to verify if the I/O data in the I/O image are valid.

Function call:

```
int32_t xChannelHostState( CIFXHANDLE    hChannel,
                          uint32_t      ulCmd,
                          uint32_t*     pulState,
                          uint32_t      ulTimeout)
```

Arguments:

Argument	Data type	Description
hChannel	CIFXHANDLE	Handle of the channel.
ulCmd	uint32_t	Host State Command Clears the application ready flag 0 = CIFX_HOST_STATE_NOT_READY Sets the application ready flag 1 = CIFX_HOST_STATE_READY Read the current state of the flag 2 = CIFX_HOST_STATE_READ
pulState	uint32_t*	Returns the actual state of the application ready flag if CIFX_HOST_STATE_READ command is used
ulTimeout	uint32_t	Timeout in milliseconds. If not 0, the function will wait the given time until the state is changed

Return Values:

CIFX_NO_ERROR if the function succeeds.

If the function fails, a nonzero error code from chapter *Error Codes* from page 107 is returned. You can use the function *xDriverGetErrorDescription()* to get a description of this error.

4.8.17 xChannelBusState

Toggle the 'Bus State Flag' in the communication channel handshake flags. Using this flag, the host application allows or disallows the firmware to open network connections. If set (CIFX_BUS_STATE_ON), the netX firmware tries to open network connections; if cleared (CIFX_BUS_STATE_OFF), no connections are allowed and open connections are closed (See reference [1] for further information).

In generally a fieldbus stack allows the configuration of the field bus start-up behavior. This can be either 'automatic startup' or 'controlled startup'. If the stack is configured in 'controlled startup' (i.e. the 'Bus State Flag' is cleared) it will not activate the bus communication until it receives a CIFX_BUS_STATE_ON state in its handshake flags.

Note: Setting the 'Bus State flag' to CIFX_BUS_STATE_ON successfully does not necessarily mean that the fieldbus stack has established a connection to the fieldbus system. The routine will signal an absent connection by returning the error code CIFX_DEV_NO_COM_FLAG (even though toggle of the 'Bus state flag' has succeeded).

Function call:

```
int32_t xChannelBusState( CIFXHANDLE    hChannel,
                        uint32_t      ulCmd,
                        uint32_t*     pulState,
                        uint32_t      ulTimeout)
```

Arguments:

Argument	Data type	Description
hChannel	CIFXHANDLE	Handle of the channel.
ulCmd	uint32_t	Bus State Commands: Clears the BUS state flag 0 = CIFX_BUS_STATE_OFF Sets the bus state flag 1 = CIFX_BUS_STATE_ON Read the actual state of the bus state flag 2 = CIFX_BUS_STATE_GETSTATE
pulState	uint32_t*	Actual state returned
ulTimeout	uint32_t	Timeout in milliseconds. If not 0, the function will wait until the communication has reached the chosen state.

Return Values:

CIFX_NO_ERROR if the function succeeds.

CIFX_DEV_NO_COM_FLAG if the function succeeds but fieldbus stack does not communicate.

If the function fails, a nonzero error code from chapter *Error Codes* from page 107 is returned. You can use the function *xDriverGetErrorDescription()* to get a description of this error.

4.8.18 xChannelControlBlock

Reading / writing the communication channel control block.

Function call:

```
int32_t xChannelControlBlock ( CIFXHANDLE    hChannel,
                              uint32_t      ulCmd,
                              uint32_t      ulOffset,
                              uint32_t      ulDataLen,
                              void*         pvData);
```

Arguments:

Argument	Data type	Description
hChannel	CIFXHANDLE	Handle of the channel.
ulCmd	uint32_t	Control block commands: Read the block area 1 = CIFX_CMD_READ_DATA Write the block area 2 = CIFX_CMD_WRITE_DATA
ulOffset	uint32_t	Start offset in the block area
ulDataLen	uint32_t	Number of bytes to read
pvData	void*	User buffer

Return Values:

CIFX_NO_ERROR if the function succeeds.

If the function fails, a nonzero error code from chapter *Error Codes* from page 107 is returned. You can use the function *xDriverGetErrorDescription()* to get a description of this error.

4.8.19 xChannelCommonStatusBlock

Read the channels common status block.

Note: Writing of the common status block by an application is not allowed

Function call:

```
int32_t xChannelCommonStatusBlock ( CIFXHANDLE    hChannel ,
                                     uint32_t      ulCmd ,
                                     uint32_t      ulOffset ,
                                     uint32_t      ulDataLen ,
                                     void*         pvData );
```

Arguments:

Argument	Data type	Description
hChannel	CIFXHANDLE	Handle of the channel.
ulCmd	uint32_t	Status block commands: Read the block area 1 = CIFX_CMD_READ_DATA
ulOffset	uint32_t	Start offset in the block area
ulDataLen	uint32_t	Number of bytes to read
pvData	void*	User buffer

Return Values:

CIFX_NO_ERROR if the function succeeds.

If the function fails, a nonzero error code from chapter *Error Codes* from page 107 is returned. You can use the function *xDriverGetErrorDescription()* to get a description of this error.

4.8.20 xChannelExtendedStatusBlock

Read the communication channels extended status block.

Note: Writing of the extended status block by an application is not allowed

Function call:

```
int32_t xChannelExtendedStatusBlock (    CIFXHANDLE    hChannel,
                                         uint32_t      ulCmd,
                                         uint32_t      ulOffset,
                                         uint32_t      ulDataLen,
                                         void*         pvData);
```

Arguments:

Argument	Data type	Description
hChannel	CIFXHANDLE	Handle of the channel.
ulCmd	uint32_t	Extended status block commands: Read the block area 1 = CIFX_CMD_READ_DATA
ulOffset	uint32_t	Start offset in the block area
ulDataLen	uint32_t	Number of bytes to read
pvData	void*	User buffer

Return Values:

CIFX_NO_ERROR if the function succeeds.

If the function fails, a nonzero error code from chapter *Error Codes* from page 107 is returned. You can use the function *xDriverGetErrorDescription()* to get a description of this error.

4.8.21 xChannelUserBlock

not implemented yet!

4.8.22 xChannellIORead

The function reads the input process data image of a communication channel and afterwards it instructs the fieldbus protocol to update input data image with actual (latest) fieldbus data.

Note: On the basis of the implementation, xChannellIORead() delivers the input data from the "last" call of xChannellIORead() and not the "latest" input data from the fieldbus system. This has the advantage that the function has not to wait for the data update of the fieldbus protocol which could need a significant time which are several hundred microseconds up to milliseconds depending to the configuration and the number of devices connected to the fieldbus system. But also the limitation that the age of the input data are depending of the cycle time used to call xChannellIORead().

Function call:

```
int32_t xChannellIORead(  CIFXHANDLE  hChannel,
                          uint32_t    ulAreaNumber,
                          uint32_t    ulOffset,
                          uint32_t    ulDataLen,
                          void*       pvData,
                          uint32_t    ulTimeout)
```

Arguments:

Argument	Data type	Description
hChannel	CIFXHANDLE	Handle of the channel.
ulAreaNumber	uint32_t	Number of the I/O Input area to get data from
ulOffset	uint32_t	Offset inside area to start reading data from
ulDataLen	uint32_t	Length of the data being retrieved
pvData	void*	Pointer to the return data buffer
ulTimeout	uint32_t	Timeout in ms to wait for I/O handshake completion of the channel (if configured)

Return Values:

CIFX_NO_ERROR if the function succeeds.

If the function fails, a nonzero error code from chapter *Error Codes* from page 107 is returned. You can use the function *xDriverGetErrorDescription()* to get a description of this error.

4.8.23 xChannellIOWrite

The function writes the output process data image of a communication channel and instructs the fieldbus protocol to send the data to the fieldbus system.

Note: The function `xChannellIOWrite()` does not wait until the data are taken by the hardware or physically transferred by the fieldbus system, because this depends at least on the fieldbus connection and the cycle time of the fieldbus system which are usually unknown.

Function call:

```
int32_t xChannellIOWrite( CIFXHANDLE hChannel,
                          uint32_t   ulAreaNumber,
                          uint32_t   ulOffset,
                          uint32_t   ulDataLen,
                          void*      pvData,
                          uint32_t   ulTimeout)
```

Arguments:

Argument	Data type	Description
hChannel	CIFXHANDLE	Handle of the channel.
ulAreaNumber	uint32_t	Number of the I/O Output area to send data to
ulOffset	uint32_t	Offset inside area to start writing data to
ulDataLen	uint32_t	Length of the data being send
pvData	void*	Pointer to the send data buffer
ulTimeout	uint32_t	Timeout in ms to wait for I/O handshake completion of the channel (if configured)

Return Values:

CIFX_NO_ERROR if the function succeeds.

If the function fails, a nonzero error code from chapter *Error Codes* from page 107 is returned. You can use the function `xDriverGetErrorDescription()` to get a description of this error.

4.8.24 xChannelIOReadSendData

Read back the actual content of the output process data image from a communication channel.

Function call:

```
int32_t xChannelIOReadSendData( CIFXHANDLE    hChannel,
                               uint32_t      ulAreaNumber,
                               uint32_t      ulOffset,
                               uint32_t      ulDataLen,
                               void*         pvData)
```

Arguments:

Argument	Data type	Description
hChannel	CIFXHANDLE	Handle of the channel.
ulAreaNumber	uint32_t	Number of the I/O Output area to get data from
ulOffset	uint32_t	Offset inside area to start reading data from
ulDataLen	uint32_t	Length of the data being received
pvData	void*	Pointer to the returned data buffer

Return Values:

CIFX_NO_ERROR if the function succeeds.

If the function fails, a nonzero error code from chapter *Error Codes* from page 107 is returned. You can use the function *xDriverGetErrorDescription()* to get a description of this error.

4.8.25 PLC I/O Image Functions

Note: Do not use `xChannelIORead()/xChannelIOWrite()` functions while using the PLC functions. If PLC functions are used, the application is responsible to synchronize I/O data access by using the `xChannelPLCsReady...()/xChannelPLCActivate...()` functions. There is no internal synchronization mechanism available to synchronize access states between `xChannelIORead()/xChannelIOWrite()` and the PLC functions. Mixing the functions will result in unpredictable I/O states.

Some of the PLC programs (Programmable Logic Controller also known as SoftPLCs) are using an own process data image layout. Such programs need to copy the process data, from the local buffers, necessary for the standard `xChannelIORead()/xChannelIOWrite()` functions, into their own data image layout. In such a case, process data are always copied two times. First time between the cards I/O process data image and the local function buffers offered by the application and the second time between the local buffers and the PLC specific process images.

PLC functions are design to save the copy between the cards I/O process data image and the local function buffers (done by `xChannelIORead()/xChannelIOWrite()`).

Therefore `xChannelIORead()` and `xChannelIOWrite()` are split into separate functions. One function to get data pointers to the input and output process data image which can be used by the application to directly access the cards I/O process data image. And two other functions to control and synchronize the access to the cards I/O process image data between the user application and the fieldbus protocol, running on the card.

- `xChannelPLCMemoryPtr`
Getting the data pointers to the cards I/O process data image
- `xChannelPLCActivateRead() / xChannelPLCActivateWrite()`
Activate the data exchange of the cards I/O process data image with the fieldbus protocol running on the card
- `xChannelPLCsReadReady() / xChannelPLCsWriteReady()`
Check if the fieldbus protocol has finished the access to the crads I/ process data image and if the application is allowed to access the data

Important for the use of the functions is a prior call to the `xChannelPLCMemoryPtr()` function. This will deliver the necessary pointers to the I/O process data image.

Note: If the PLC functions are used, the application is responsible to synchronize the data access between the host and the communication channel.

Before closing an application, all memory pointers retrieved by calling `xChannelPLCMemoryPtr()`, (command **CIFX_MEM_PTR_OPEN**) should be returned to the system to avoid memory leaks. Pointers are returned by calling `xChannelPLCMemoryPtr()` using the **CIFX_MEM_PTR_CLOSE** command.

4.8.25.1 xChannelPLCMemoryPtr

Retrieve a memory pointer to the I/O data area for a PLC (Programmable Logic Controller). This enables an application to write data directly to the dual port memory (I/O data image) without doing a combined handshake like in *xChannelIORead()* or *xChannelIOWrite()*.

Before closing an application, all retrieved pointers should be released to avoid system memory leaks. Releasing a pointer is done by calling *xChannelPLCMemoryPtr()* using the **CIFX_MEM_PTR_CLOSE** command.

Function call:

```
int32_t xChannelPLCMemoryPtr( CIFXHANDLE hChannel,
                             uint32_t ulCmd,
                             void* pvMemoryInfo)
```

Arguments:

Argument	Data type	Description
hChannel	CIFXHANDLE	Handle of the channel.
ulCmd	uint32_t	PLC Memory Pointer Commands: Acquire a memory pointer 1 = CIFX_MEM_PTR_OPEN Map a user specific memory area 2 = CIFX_MEM_PTR_USR -> not supported Release a memory pointer 3 = CIFX_MEM_PTR_CLOSE
pvMemoryInfo	void*	Pointer to PLC_MEMORY_INFORMATION structure. This structure describes the requested area and also contains the returned memory pointer on success

Return Values:

CIFX_NO_ERROR if the function succeeds.

If the function fails, a nonzero error code from chapter *Error Codes* from page 107 is returned. You can use the function *xDriverGetErrorDescription()* to get a description of this error.

Description of the PLC_MEMORY_INFORMATION Structure:

Value	Data type	Description
pvMemoryID	void*	Identifier of the memory area
ppvMemoryPtr	void**	Memory pointer
ulAreaDefinition	uint32_t	Input / Output area
ulAreaNumber	uint32_t	Area number (0..1)
pulIOAreaStartOffset	uint32_t*	Buffer to store the I/O area start offset
pulAreaSize	uint32_t*	Buffer to store the size of the I/O area

PLC_MEMORY_INFORMATION Structure:

```

/*****
/*! PLC Memory Information structure */
/*****
typedef __CIFX_PACKED_PRE struct PLC_MEMORY_INFORMATIONtag
{
    void*          pvMemoryID;          /*!< Identification of the memory area */
    void**         ppvMemoryPtr;        /*!< Memory pointer */
    uint32_t       ulAreaDefinition;    /*!< Input/output area */
    uint32_t       ulAreaNumber;        /*!< Area number */
    uint32_t*      pulIOAreaStartOffset; /*!< Start offset */
    uint32_t*      pulIOAreaSize;       /*!< Memory size */
} __CIFX_PACKED_POST PLC_MEMORY_INFORMATION;

```

Example:

```

//=====
// Test PLC Functions
//
//
//=====
void TestPLCFunctions( void)
{
    unsigned char abBuffer[1000] = {0};
    uint32_t       ulState        = 0;

    printf("\n--- Test PLC functions ---\r\n");

    long lRet = CIFX_NO_ERROR;

    /* Open channel */
    HANDLE hDevice = NULL;
    lRet = xChannelOpen(NULL, "CIFx0", 0, &hDevice);
    if(lRet != CIFX_NO_ERROR)
    {
        ShowError(lRet);
    } else
    {
        /* Start PLC functions */
        unsigned char* pabDPMMemory      = NULL;
        uint32_t       ulAreaStartOffset = 0;
        uint32_t       ulAreaSize        = 0;
        long           lRet                = CIFX_NO_ERROR;
        long           lRetIN              = CIFX_NO_ERROR;
        long           lRetOUT             = CIFX_NO_ERROR;

        /* Define the memory structures for Input data */
        PLC_MEMORY_INFORMATION tMemory = {0};
        tMemory.pvMemoryID          = NULL; // Identification of the memory area
        tMemory.ppvMemoryPtr        = (void*)&pabDPMMemory; // Memory pointer
        tMemory.ulAreaDefinition     = CIFX_IO_INPUT_AREA; // Input/output area
        tMemory.ulAreaNumber        = 0; // Area number
        tMemory.pulIOAreaStartOffset = &ulAreaStartOffset; // Start offset of the requested channel
        tMemory.pulIOAreaSize       = &ulAreaSize; // Memory size of the requested channel

        /* Define the memory structures for Output data */

```

```

unsigned char*   pabDPMMemory_OUT      = NULL;
uint32_t        ulAreaStartOffset_OUT  = 0;
uint32_t        ulAreaSize_OUT         = 0;

PLC_MEMORY_INFORMATION tMemory_OUT = {0};
tMemory_OUT.pvMemoryID      = NULL;           // Identification of the memory
area
tMemory_OUT.ppvMemoryPtr    = (void*)&pabDPMMemory_OUT; // Memory pointer
tMemory_OUT.ulAreaDefinition = CIFX_IO_OUTPUT_AREA;     // Input/output area
tMemory_OUT.ulAreaNumber    = 0;              // Area number
tMemory_OUT.pulIOAreaStartOffset = &ulAreaStartOffset_OUT; // Start offset of the requested
channel
tMemory_OUT.pulIOAreaSize   = &ulAreaSize_OUT;       // Memory size of the requested
channel

/* Open a DPM memory pointer */
if ( (CIFX_NO_ERROR != (lRetIN = xChannelPLCMemoryPtr( hDevice, CIFX_MEM_PTR_OPEN, &tMemory))) )
||
    (CIFX_NO_ERROR != (lRetOUT = xChannelPLCMemoryPtr( hDevice, CIFX_MEM_PTR_OPEN,
&tMemory_OUT))) )
{
    // Failed to get the memory mapping
    ShowError( lRetIN);
    ShowError( lRetOUT);
} else
{
    uint32_t ulWaitBusCount = 100;

    /* Signal application is ready */
    lRet = xChannelHostState( hDevice, CIFX_HOST_STATE_READY, &ulState, 100);
    if( CIFX_NO_ERROR != lRet)
    {
        ShowError(lRet);
    }

    /* Wait until BUS is up and running */
    printf("\r\nWait until BUS communication is available!\r\n");
    do
    {
        lRet = xChannelBusState( hDevice, CIFX_BUS_STATE_ON, &ulState, 100);
        if( CIFX_NO_ERROR != lRet)
        {
            if( CIFX_DEV_NO_COM_FLAG != lRet)
            {
                ShowError(lRet);
                break;
            }
        } else if( 1 == ulState)
        {
            /* Bus is ON */
            printf("\r\nBUS is ON!\r\n");
            break;
        }
    } while ( --ulWaitBusCount > 0);

    if( 0 == ulWaitBusCount)
    {
        ShowError(lRet);
    }

    /*-----*/
    /* Start cyclic data IO */
    /*-----*/
    if( CIFX_NO_ERROR == lRet)
    {
        printf("\n Press any key to stop \r\n");
        while (!_kbhit())
        {
            // We have a memory mapping, check if access to the DPM is allowed
            uint32_t ulReadState = 0;
            uint32_t ulWriteState = 0;

            /*-----*/
            /* Check if we can access the INPUT image */
            /*-----*/

            lRet = xChannelPLCIsReadReady ( hDevice, 0, &ulReadState);
            if( CIFX_NO_ERROR != lRet)
            {

```

```

    ShowError( lRet);
} else if( 1 == ulReadState)
{
    /* It is allowed to read the image */
    /* Read 100 Bytes */
    memcpy( abBuffer, pabDPMMemory, sizeof(abBuffer));

    /* Activate transfer */
    lRet = xChannelPLCActivateRead ( hDevice, 0);
    if( CIFX_NO_ERROR != lRet)
        ShowError( lRet);
}

/*-----*/
/* Check if we can access the OUTPUT image */
/*-----*/
lRet = xChannelPLCIsWriteReady ( hDevice, 0, &ulWriteState);
if( CIFX_NO_ERROR != lRet)
{
    ShowError( lRet);
} else if( 1 == ulWriteState)
{
    /* It is allowed to write the image */
    pabDPMMemory_OUT[0]++;
    pabDPMMemory_OUT[1] = abBuffer[1];

    lRet = xChannelPLCActivateWrite ( hDevice, 0);
    if( CIFX_NO_ERROR != lRet)
        ShowError( lRet);
}
}

/* clean keyboard buffer */
_getch();
}

lRet = xChannelBusState( hDevice, CIFX_BUS_STATE_OFF, &ulState, 100);
if(CIFX_NO_ERROR != lRet)
{
    ShowError(lRet);
}

lRet = xChannelHostState( hDevice, CIFX_HOST_STATE_NOT_READY, &ulState, 100);
if(CIFX_NO_ERROR != lRet)
{
    ShowError(lRet);
}

/* Return the DPM memory pointer */
if ( NULL != pabDPMMemory)
{
    lRet = xChannelPLCMemoryPtr( hDevice, CIFX_MEM_PTR_CLOSE, &tMemory);
    if(lRet != CIFX_NO_ERROR)
        /* Failed to return memory pointer */
        ShowError( lRet);
}

/* Return the DPM memory pointer */
if ( NULL != pabDPMMemory_OUT)
{
    lRet = xChannelPLCMemoryPtr( hDevice, CIFX_MEM_PTR_CLOSE, &tMemory_OUT);
    if(lRet != CIFX_NO_ERROR)
        /* Failed to return memory pointer */
        ShowError( lRet);
}

// Close channel
if( hDevice != NULL) xChannelClose(hDevice);
}

printf("\n Test PLC functions done\r\n");
}

```

4.8.25.2 xChannelPLCActivateRead

Instruct the communication channel to refresh the input process data image. The end of the update cycle must be checked by the application using the function `xChannelPLCsReadReady()`

Note: Do not call this function while the actual state is '*not finished*' (check with the corresponding `xChannelPLCs.....Ready()` function), otherwise the result is unpredictable.

Function call:

```
int32_t xChannelPLCActivateRead(    CIFXHANDLE    hChannel,
                                   uint32_t        ulAreaNumber)
```

Arguments:

Argument	Data type	Description
hChannel	CIFXHANDLE	Handle of the channel.
ulAreaNumber	uint32_t	Number of the I/O area to request a input data refresh

Return Values:

CIFX_NO_ERROR if the function succeeds.

If the function fails, a nonzero error code from chapter *Error Codes* from page 107 is returned. You can use the function `xDriverGetErrorDescription()` to get a description of this error.

4.8.25.3 xChannelPLCActivateWrite

Instruct the communication channel to refresh the output process data image with the data from the dual port memory. The end of the update cycle must be checked by the user application, using the function `xChannelPLCsWriteReady()`.

Note: Do not call this function while the actual state is '*not finished*' (check with the corresponding `xChannelPLCs.....Ready()` function), otherwise the result is unpredictable.

Function call:

```
int32_t xChannelPLCActivateWrite(  CIFXHANDLE  hChannel,
                                  uint32_t      ulAreaNumber)
```

Arguments:

Argument	Data type	Description
hChannel	CIFXHANDLE	Handle of the channel.
ulAreaNumber	uint32_t	Number of the I/O area to request a output data refresh

Return Values:

CIFX_NO_ERROR if the function succeeds.

If the function fails, a nonzero error code from chapter *Error Codes* from page 107 is returned. You can use the function `xDriverGetErrorDescription()` to get a description of this error.

4.8.25.4 xChannelPLCIsReadReady

Check if the last read request of the I/O data image is processed and finished by the hardware.

Function call:

```
int32_t xChannelPLCIsReadReady( CIFXHANDLE    hChannel,
                               uint32_t      ulAreaNumber,
                               uint32_t*     pulReadState)
```

Arguments:

Argument	Data type	Description
hChannel	CIFXHANDLE	Handle of the channel.
ulAreaNumber	uint32_t	Number of the I/O area to check for read request completion
pulReadState	uint32_t *	Returned state of the handshake operation 0 = pending !=0 = finished

Return Values:

CIFX_NO_ERROR if the function succeeds.

If the function fails, a nonzero error code from chapter *Error Codes* from page 107 is returned. You can use the function *xDriverGetErrorDescription()* to get a description of this error.

4.8.25.5 xChannelPLCIsWriteReady

Check if the last write request handshake is processed and finished by the hardware.

Function call:

```
int32_t xChannelPLCIsWriteReady(    CIFXHANDLE    hChannel,
                                   uint32_t         ulAreaNumber,
                                   uint32_t*         pulWriteState)
```

Arguments:

Argument	Data type	Description
hChannel	CIFXHANDLE	Handle of the channel.
ulAreaNumber	uint32_t	Number of the I/O area to check for read request completion
pulWriteState	uint32_t*	Returned state of the handshake operation 0 = pending !=0 = finished

Return Values:

CIFX_NO_ERROR if the function succeeds.

If the function fails, a nonzero error code from chapter *Error Codes* from page 107 is returned. You can use the function *xDriverGetErrorDescription()* to get a description of this error.

4.8.26 DMA Functions

4.8.26.1 xChannelDMAState

Toggle the '*DMA Enable Flag*' in the communication channel handshake flags. This function can be used to change the I/O image transfer from DPM to bus-master-DMA mode. If PLC memory functions are used, the I/O image pointers need to be re-read after enabling/disabling DMA mode.

Note: DMA is only possible on PCI based hardware. On none PCI based hardware, this function is not available and will return with an error

Function call:

```
int32_t xChannelDMAState( CIFXHANDLE hChannel,
                        uint32_t ulCmd,
                        uint32_t* pulState)
```

Arguments:

Argument	Data type	Description
hChannel	CIFXHANDLE	Handle of the channel.
ulCmd	uint32_t	DMA State Commands: Disable DMA mode 0 = CIFX_DMA_STATE_OFF Enable DMA mode 1 = CIFX_DMA_STATE_ON Get actual DMA state 2 = CIFX_DMA_STATE_GETSTATE
pulState	uint32_t*	Actual state returned

Return Values:

CIFX_NO_ERROR if the function succeeds.

If the function fails, a nonzero error code from chapter *Error Codes* from page 107 is returned. You can use the function *xDriverGetErrorDescription()* to get a description of this error.

4.8.27 Notification Functions

Notification functions can be used for devices running in interrupt mode. These functions are registering a callback for pre-defined events from the hardware.

The callback function is called if the corresponding event occurs on the device.

Note: Notification functions are only available for devices running in interrupt mode.

Available Notifications

Notification	Definition	Description
Packet transfer	CIFX_NOTIFY_RX_MBX_FULL	Receive mailbox full (packet available)
	CIFX_NOTIFY_TX_MBX_EMPTY	Send mailbox is empty (packet can be send)
I/O data transfer	CIFX_NOTIFY_PD0_IN	Input area 0 has been processed (see below)
	CIFX_NOTIFY_PD1_IN	Input area 1 has been processed (see below)
	CIFX_NOTIFY_PD0_OUT	Output area 0 has been processed (see below)
	CIFX_NOTIFY_PD1_OUT	Output area 1 has been processed (see below)
Synchronization	CIFX_NOTIFY_SYNC	Fieldbus synchronous event occurred
Communication Flag State	CIFX_NOTIFY_COM_STATE	Communication state of the communication channel has changed

4.8.27.1 Packet Transfer Notifications

Packet transfer is used for asynchronous command/confirmation data (e. g. SDOs).

Packet data are handled via a mailbox system. In interrupt mode the actual state of the mailbox system (send/receive mailbox) can be signaled by notifications (see above).

4.8.27.2 I/O Data Transfer Notifications

The result of the I/O handling and the corresponding notifications which can be signaled to the user application are depending on the configured I/O data exchange mode. This also effect the handling in the user application, when it is reasonable to call xChannellIORead() and xChannellIOWrite().

Note: "I/O Data Transfer" notifications depending on the so called "I/O Exchange Mode" configured on the device. These modes are defining how notifications are created by the device state changes. The callback functions are called if the driver detects a state change in the device handshake flags. How the application processes the notification is part of the application development and must correspond to the configured mode settings of the device. Handshake modes are described in [1].

Handshake modes are defining which part (device/host) is the active part.

Following modes are known:

I/O Exchange mode	Description
uncontrolled	No data access synchronization between host and device. Both systems are running independent of each other and data are exchanged without taking care about data consistency. Notification: NONE
buffered host controlled (default)	The host activates the data transfer between device and host. Actual I/O data from the fieldbus system and from the host are always stored in the local I/O buffers on the device. If the host requests new input data (calling xChannellIORead()), the device will copy the currently available input data from the local buffer to the DPM (PDx_IN area) and signals "data updated" (1). The host can read the new input data with the next call to xChannellIORead(). If the host writes new output data to the DPM (PDx_OUT area) by calling xChannellIOWrite(). The device, will copy the data from the DPM to the local output buffer and signals "data updated" (2) if the copy is done. (1) Notification for the input data: CIFX_NOTIFY_PDx_IN (2) Notification for the output data: CIFX_NOTIFY_PDx_OUT
buffered device controlled	ATTENTION: By default NOT supported from Hilscher Stacks The device will start to copy the actual input data from the fieldbus system to the DPM (PDx_IN area) and signals "input data updated" (1). The user has to call xChannellIORead() to read the input data from the DPM. All further input data received by the fieldbus are stored in the device local input buffer until the host reads the data again. The device requests new output data from the host (2) and until the host has written new data, output data are send from the local device buffer to the fieldbus system. If the host writes new output data (calling xChannellIOWrite()) , the device copies the data to the local output buffer and requests (2) new output data as soon as the copy of the data is done. (1) Notification for the input data: CIFX_NOTIFY_PDx_IN (2) Notification for the output data: CIFX_NOTIFY_PDx_OUT

Data Exchange Mode - Buffered Host Controlled I/O:

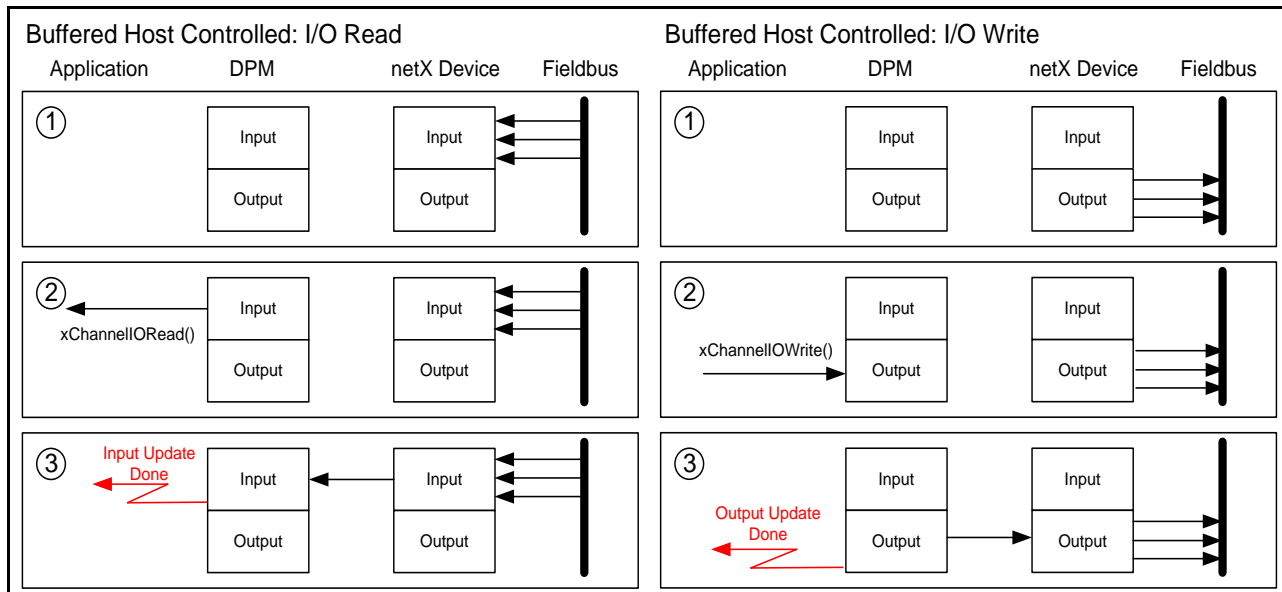

Figure 3: Data Exchange Mode: Buffered Host Controlled I/O

I/O Read		I/O Write	
Step	Description	Step	Description
1	Fieldbus protocol reads input data from the fieldbus system and stores the data in the internal " Input Buffer "	1	Fieldbus protocol sends the output data stored in the internal " Output Buffer " to the fieldbus system
2	Application uses xChannelIORead() which reads the actual data from the DPM (Dual-Ported Memory) PD-IN area and signals the card to update the PD-IN area.	2	Application calls xChannelIOWrite() which write the actual user data to the DPM (Dual-Ported Memory) PD-OUT area and signals the card to update the internal " Output Buffer ".
3	The stack copies the actual data form the internal " Input Buffer " (holding the latest input data) to the DPM PD-IN area. After the data copy, the protocol stack signals " Input Update Done " which schedules a CIFX_NOTIFY_PDx_IN notification.	3	The stack copies the data from the DPM PB-OUT area to the internal " Output Buffer ". After the data copy, the protocol stack signals " Output Update Done " which schedules a CIFX_NOTIFY_PDx_OUT notification.

Note: In these modes, the notifications just inform the application when the input data are copied from the device local input buffer to the DPM and when the output data are copied from the DPM to the device local output buffer. There is no synchronization with any fieldbus data cycle.

Data Exchange Mode - Buffered Device Controlled I/O

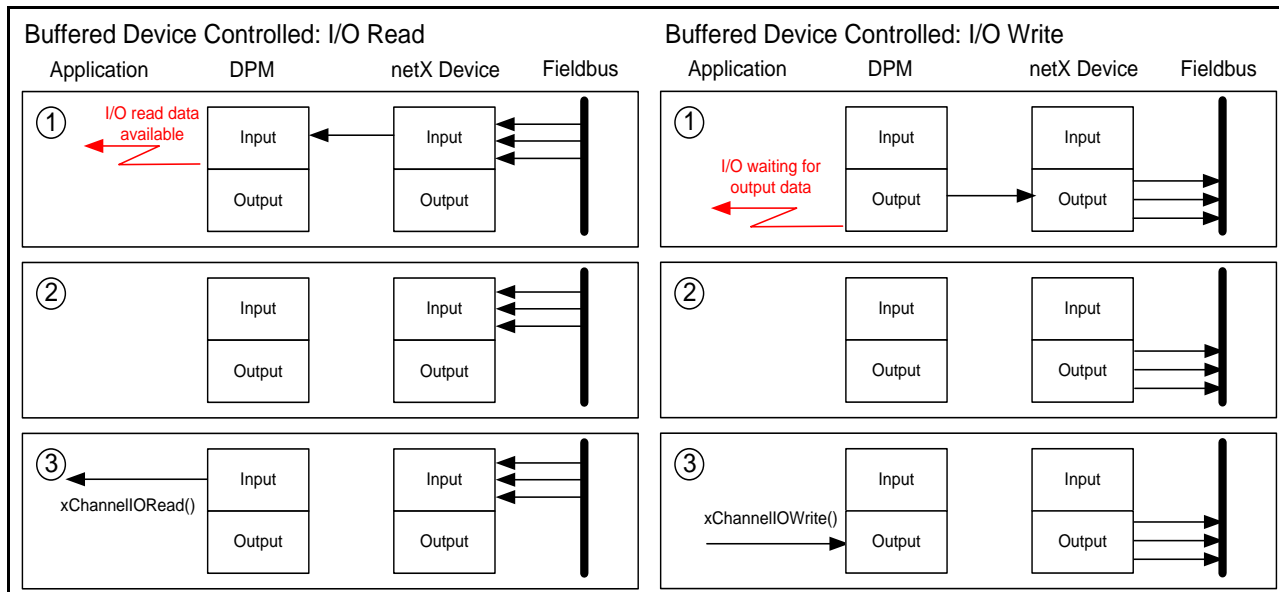

Figure 4: Data Exchange Mode: Buffered Device Controlled I/O

I/O Read		I/O Write	
Step	Description	Step	Description
1	Fieldbus protocol reads input data from the fieldbus system and stores the data in the internal "Input Buffer", copies the data to the DPM (PDx_IN) area. After writing the input data to the DPM (PDx_IN), the device signals "I/O read data available" scheduling a CIFX_NOTIFY_PDx_IN notification.	1	The device takes the output data from the DPM (PDx_OUT area) and copies it to the device local "Output Buffer". After the copy the device requests new output data by signaling a CIFX_NOTIFY_PDx_OUT notification.
2	Any further data from a bus cycle will be stored in the device local input buffer.	2	The device sends the stored output with any further bus cycle
3	If the host reads the input data (by calling <code>xChannelIORead()</code>), the device is signaled "Input data done" than the device is able to update the input data again.	3	If the host writes new output data to the DPM (PDx_OUT) by calling <code>xChannelIOWrite()</code> . The device is signaled "New output data available".

Note: The application determines when read input or write output data. The notification informs the application when read or write is possible. There is no synchronization with any fieldbus data cycle.

Determining the Configured "I/O Exchange Mode":

The configured I/O data exchange (host controlled/device controlled) can be read from the communication channels "Common Status Block" (bPDInHskMode / (bPDOutHskMode). The block can be read and evaluated by the user application using the *xChannelCommonStatusBlock()* function.

The "Common Status Block" is described in the "netX Dual-Port Memory Interface DPM Manual".

Following data exchanges mode definitions are available:

```
/* Block definition: I/O Mode */
#define RCX_IO_MODE_DEFAULT      0x0000    /*!< I/O mode default, for compability reasons this
value is identical to 0x4 (buffered host controlled) */
#define RCX_IO_MODE_BUFF_DEV_CTRL 0x0002    /*!< I/O mode buffered device controlled */
#define RCX_IO_MODE_UNCONTROLLED 0x0003    /*!< I/O mode bus synchronous device controlled */
#define RCX_IO_MODE_BUFF_HST_CTRL 0x0004    /*!< I/O mode buffered host controlled */
```

Note: Possible data exchanges modes are fieldbus protocol specific and described in the corresponding fieldbus "Protocol API" manual.

4.8.27.3 Bus Synchronization Notifications

The notification functions offering a bus synchronization event if supported by the fieldbus protocol.

Note: "Synchronization" notifications" depending on the so called "Synchronization Mode" configured on the device.

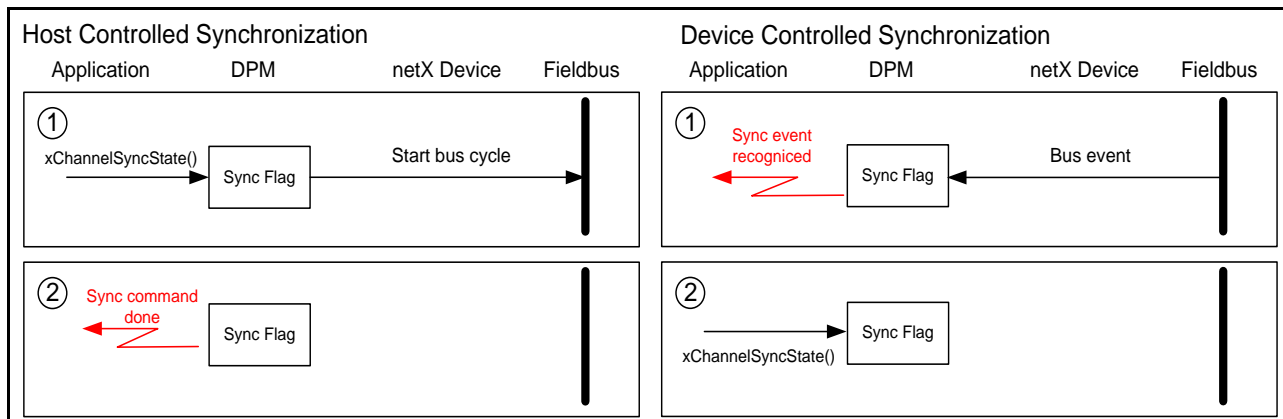

Figure 5: Bus Synchronization Notifications

Host Controlled Synchronization		Device Controlled Synchronization	
Step	Description	Step	Description
1	The application starts to send a synchronization command <code>xChannelSyncState(CIFX_SYNC_SIGNAL_CMD)</code> to the device. Depending on the configuration the synchronization command (e.g. start bus cycle) is executed by the device.	1	If the fieldbus protocol recognizes the configured sync event, it signals a "Sync event recognized" and scheduled a <code>CIFX_NOTIFY_SYNC</code> notification.
2	The device signals "Sync command done", by scheduling a <code>CIFX_NOTIFY_SYNC</code> notification if the command is processed.	2	Application has to call <code>xChannelSyncState(CIFX_SYNC_SIGNAL_ACK)</code> before a new bus event is signaled again.

Determining the Configured "Synchronization Mode":

The configured synchronization mode (host controlled/device controlled) can be read from the communication channels "Common Status Block" (`bSynchskMode`). The block can be read and evaluated by the user application using the `xChannelCommonStatusBlock()` function.

The "Common Status Block" is described in the "netX Dual-Port Memory Interface DPM Manual".

Following synchronization mode definitions are available:

```

/* Block definition: Synchronization Mode */
#define RCX_SYNC_MODE_OFF                0x00
#define RCX_SYNC_MODE_DEV_CTRL          0x01
#define RCX_SYNC_MODE_HST_CTRL          0x02
    
```

Note: Possible synchronization modes are fieldbus protocol specific and described in the corresponding fieldbus "Protocol API" manual

4.8.27.4 PFN_NOTIFY_CALLBACK - Callback Function Definition

Note: The registered callback function will be invoked as soon as the callback is registered and the corresponding event is valid. This could also happen while the user application is still in the *xChannelRegisterNotification()* function call.

```
void NotificationCallback( uint32_t   ulNotification,
                          uint32_t   ulDataLen,
                          void*      pvData
                          void*      pvUser );
```

Arguments:

Argument	Data type	Description
ulNotification	uint32_t	Occurred event
ulDataLen	uint32_t	Length of additional data
pvData	void*	Additional Data (depends on ulNotification)
pvUser	void*	User parameter from registration

Possible Notification Events:

ulNotification	Passed Data	Description
CIFX_NOTIFY_RX_MBX_FULL	Pointer to CIFX_NOTIFY_RX_MBX_FULL_DATA_T structure containing the total number of packets waiting to be read from the device.	Signaled when receive mailbox becomes full and a data packet is available to read.
CIFX_NOTIFY_TX_MBX_EMPTY	Pointer to CIFX_NOTIFY_TX_MBX_EMPTY_DATA_T structure containing the maximum amount of packets which can be send to the device.	Send mailbox becomes empty and a new packet can be send to the device.
CIFX_NOTIFY_PD0_IN	none	Input area 0 has been processed
CIFX_NOTIFY_PD1_IN	none	Input area 1 has been processed
CIFX_NOTIFY_PD0_OUT	none	Output area 0 has been processed
CIFX_NOTIFY_PD1_OUT	none	Output area 1 has been processed
CIFX_NOTIFY_SYNC	none	Bus synchronization notification, signals the SYNC event on the fieldbus/device occurred.
CIFX_NOTIFY_COM	Pointer to CIFX_NOTIFY_COM_STATE_T structure containing the actual state of the COM-flag	Communication flag notification. Signals state changes of the COM-flag (set or cleared).

4.8.27.5 xChannelRegisterNotification

Register an event callback for channel events.

Depending on the event type additional information is passed in the callback. If a callback is already registered for the given event, the function will return an error.

It is not possible to register multiple applications for the same notification.

Note: The registered callback function will be invoked as soon as the callback is registered and the corresponding event is valid. This could also happen while the user application is still in the `xChannelRegisterNotification()` function call.

Function call:

```
int32_t xChannelRegisterNotification(    CIFXHANDLE        hChannel,
                                        uint32_t          ulNotification,
                                        PFN_NOTIFY_CALLBACK pfnCallback,
                                        void*              pvUser);
```

Arguments:

Argument	Data type	Description
hChannel	CIFXHANDLE	Handle of the channel.
ulNotification	uint32_t	Possible Notification: 1 = CIFX_NOTIFY_RX_MBX_FULL 2 = CIFX_NOTIFY_TX_MBX_EMPTY 3 = CIFX_NOTIFY_PD0_IN 4 = CIFX_NOTIFY_PD1_IN 5 = CIFX_NOTIFY_PD0_OUT 6 = CIFX_NOTIFY_PD1_OUT 7 = CIFX_NOTIFY_SYNC 8 = CIFX_NOTIFY_COM
pfnCallback	PFN_NOTIFY_CALLBACK	Function to be called if event occurs
pvUser	void*	Parameter passed to callback

Return Values:

CIFX_NO_ERROR if the function succeeds.

If the function fails, a nonzero error code from chapter *Error Codes* from page 107 is returned. You can use the function `xDriverGetErrorDescription()` to get a description of this error.

4.8.27.6 xChannelUnregisterNotification

Un-registers a previously registered notification event callback function for channel events.

Function call:

```
int32_t xChannelUnregisterNotification( CIFXHANDLE hChannel,
                                       uint32_t ulNotification );
```

Arguments:

Argument	Data type	Description
hChannel	CIFXHANDLE	Handle of the channel.
ulNotification	uint32_t	Possible Notification: 1 = CIFX_NOTIFY_RX_MBX_FULL 2 = CIFX_NOTIFY_TX_MBX_EMPTY 3 = CIFX_NOTIFY_PD0_IN 4 = CIFX_NOTIFY_PD1_IN 5 = CIFX_NOTIFY_PD0_OUT 6 = CIFX_NOTIFY_PD1_OUT 7 = CIFX_NOTIFY_SYNC 8 = CIFX_NOTIFY_COM

Return Values:

CIFX_NO_ERROR if the function succeeds.

If the function fails, a nonzero error code from chapter *Error Codes* from page 107 is returned. You can use the function *xDriverGetErrorDescription()* to get a description of this error.

4.8.28 Fieldbus Synchronization Handling

Certain fieldbus protocol stacks are offering so call synchronization functionalities to synchronize devices connected to a fieldbus system.

Such synchronization functions are handled independent from of the cyclic I/O data transfer.

General Definition:

In general, synchronization handling distinguishes between device synchronization and host synchronization operation. The difference between the two modes is the component (host / device) which activates the synchronization and the response to the synchronization signal (event).

- **Host Controlled Synchronization**
In this mode, the host signals a synchronization to the hardware and the hardware has to respond to this signal
- **Device Controlled Synchronization**
In this case, the device starts to signal a synchronization event and the host has to acknowledge the reception of the synch signal.

Synchronization must be handled by the user application and can be done in polling mode (not preferred) and interrupt mode of the hardware. In interrupt mode the drivers notification function is used to handle synchronization event via a user callback function.

Synchronization Handling in Polling Mode:

In polling mode the `xChannelSyncState()` function is used to activate (**CIFX_SYNC_SIGNAL_CMD**) or to acknowledge (**CIFX_SYNC_ACKNOWLEDGE_CMD**) a synchronization signal, depending on the configured fieldbus synchronization mode (host controlled / device controlled).

`xChannelSyncState()` can also be used to check (`ulTimeout == 0`) or to wait (`ulTimeout != 0`) for a device synchronization signal. Or until a new host synchronization command can be initiated.

Synchronization Handling in Interrupt Mode:

In interrupt mode, the drivers register notification function is used to handle synchronization events. A user application is able to register a callback function for synchronization events (**CIFX_SYNC_EVENT**). The registered callback function will be executed if either the device is signaling a synchronization event or if the device acknowledges a synchronization command initiated by the host application.

- **Device Synchronization Mode**
The host has to register for a synchronization event and if the event occurs (callback function is invoked) the host has to acknowledge the event using the `xChannelSyncState(...CIFX_SYNC_ACKNOWLEDGE_CMD...)`.
- **Host Synchronization Mode**
The host calls `xChannelSyncState(...CIFX_SYNC_SIGNAL_CMD...)` to signal a synchronization. The registered callback function will be invoked if the device acknowledges the command.

Verifying Synchronization Misses:

xChannelSyncState() offers a pointer to an error counter buffer (*pulErrorCount*). This counter can be used by the user application to determine the lost of a synchronization signals.

A changing error counter value between two subsequent *xChannelSyncState()* calls indicates a lost signal. This means, in "Host Controlled Mode", the device was not quick enough to process the previous command and in "Device Controlled Mode", the host has not acknowledged the synchronization signal until the next synchronization signal was initiated.

Determining the Configured Synchronization Mode:

The configured synchronization mode (host controlled / device controlled) can be read from the communication channels "Common Status Block" (*bSynchHskMode*). The block can be read and evaluated by the user application using the *xChannelCommonStatusBlock()* function.

The "Common Status Block" is described in the "netX Dual-Port Memory Interface DPM Manual".

Currently the following synchronization modes are defined.

```
/* Block definition: Synchronization Mode */
#define RCX_SYNC_MODE_OFF 0x00
#define RCX_SYNC_MODE_DEV_CTRL 0x01
#define RCX_SYNC_MODE_HST_CTRL 0x02
```

Also the synchronization error counter (*bErrorSyncCnt*) and the synchronization source (*bSyncSource*) can be evaluated from the "Common Status Block".

Note: Fieldbus synchronization must be supported by the used fieldbus protocol stack. Please consult the corresponding fieldbus "Protocol API" manual to make sure synchronization is supported.

Note: Synchronization operation assumes a corresponding fieldbus configuration.

Note: Fieldbus synchronization is a time critical process and should be processed as fast as possible. On Windows operating systems, responds times to synchronization events are not guaranteed and can lead in serious jitter. Usually synchronization will be handled in interrupt mode.

The *xChannelSyncState()* function can also be used in polling mode using a timeout and the `CIFX_SYNC_WAIT_CMD` command, but this will not change the Windows operating system respond timing issues.

Function call:

```
int32_t xChannelSyncState(CIFXHANDLE hChannel,
                        uint32_t ulCmd,
                        uint32_t ulTimeout,
                        uint32_t* pulErrorCount)
```

Arguments:

Argument	Data type	Description
hChannel	CIFXHANDLE	Handle of the channel.
ulCmd	uint32_t	Synchronization Commands: Signal sync to device 1 = CIFX_SYNC_SIGNAL_CMD Acknowledge a sync that has been set by the device 2 = CIFX_SYNC_ACKNOWLEDGE_CMD Wait for sync being signaled by device (Device Controlled), or until host can signal new Sync State (Host Controlled) 3 = CIFX_SYNC_WAIT_CMD
ulTimeout	uint32_t	Timeout in ms to wait until bits can be signaled or have been signaled by the device
pulErrorCount	uint32_t*	Returned Actual Sync Error counter

Return Values:

`CIFX_NO_ERROR` if the function succeeds.

If the function fails, a nonzero error code from chapter *Error Codes* from page 107 is returned. You can use the function *xDriverGetErrorDescription()* to get a description of this error.

5 Simple C-Application Example

The simple C application demonstrates the minimum functions which must be called to enable an application to work with a CIFX/COMX/netX based hardware.

The example is named CIFXDEMO and the source, including a Microsoft Visual C++ 6.0 project, can be found on the Hilscher system CDs.

5.1 The Main() Function

```
/* *****  
/* ! The main function  
/* \return 0 on success  
/* *****  
int main(int argc, char* argv[])  
{  
    HANDLE hDriver = NULL;  
    int32_t lRet = CIFX_NO_ERROR;  
    UNREFERENCED_PARAMETER(argc);  
    UNREFERENCED_PARAMETER(argv);  
  
    /* Open the cifX driver */  
    lRet = xDriverOpen(&hDriver);  
    if(CIFX_NO_ERROR != lRet)  
    {  
        printf("Error opening driver. lRet=0x%08X\r\n", lRet);  
    } else  
    {  
        /* Example how to find a cifX/comX board */  
        EnumBoardDemo(hDriver);  
        /* Example how to communicate with the SYSTEM device of a board */  
        SysdeviceDemo(hDriver, "cifX0");  
        /* Example how to communicate with a communication channel on a board */  
        ChannelDemo(hDriver, "cifX0", 0);  
  
        /* Close the cifX driver */  
        xDriverClose(hDriver);  
    }  
    return 0;  
}
```

5.2 System Device Example

```

/*****
*! Function to demonstrate system device functionality (Packet Transfer)
*   \return CIFX_NO_ERROR on success
*/
/*****
int32_t SysdeviceDemo(HANDLE hDriver, char* szBoard)
{
    int32_t    lRet = CIFX_NO_ERROR;
    HANDLE hSys = NULL;
    printf("----- System Device handling demo ----- \r\n");
    /* Driver/Toolkit successfully opened */
    lRet = xSysdeviceOpen(hDriver, szBoard, &hSys);
    if(CIFX_NO_ERROR != lRet)
    {
        printf("Error opening SystemDevice! \r\n");
    } else
    {
        SYSTEM_CHANNEL_SYSTEM_INFO_BLOCK tSysInfo      = {0};
        uint32_t                          ulSendPktCount = 0;
        uint32_t                          ulRecvPktCount = 0;
        CIFX_PACKET                       tSendPkt      = {0};
        CIFX_PACKET                       tRecvPkt      = {0};

        /* System channel successfully opened, try to read the System Info Block */
        if( CIFX_NO_ERROR != (lRet = xSysdeviceInfo(hSys,
                                                    CIFX_INFO_CMD_SYSTEM_INFO_BLOCK,
                                                    sizeof(tSysInfo),
                                                    &tSysInfo)))
        {
            printf("Error querying system information block \r\n");
        } else
        {
            printf("System Channel Info Block: \r\n");
            printf("DPM Size           : %u \r\n", tSysInfo.ulDpmTotalSize);
            printf("Device Number      : %u \r\n", tSysInfo.ulDeviceNumber);
            printf("Serial Number     : %u \r\n", tSysInfo.ulSerialNumber);
            printf("Manufacturer      : %u \r\n", tSysInfo.usManufacturer);
            printf("Production Date   : %u \r\n", tSysInfo.usProductionDate);
            printf("Device Class      : %u \r\n", tSysInfo.usDeviceClass);
            printf("HW Revision       : %u \r\n", tSysInfo.bHwRevision);
            printf("HW Compatibility  : %u \r\n", tSysInfo.bHwCompatibility);
        }
    }
}

```

```

/* Do a simple Packet exchange via system channel */
xSysdeviceGetMBXState(hSys, &ulRecvPktCount, &ulSendPktCount);
printf("System Mailbox State: MaxSend = %u, Pending Receive = %u\r\n",
      ulSendPktCount, ulRecvPktCount);

if(CIFX_NO_ERROR != (lRet = xSysdevicePutPacket(hSys,
                                               &tSendPkt,
                                               PACKET_WAIT_TIMEOUT)))
{
    printf("Error sending packet to device!\r\n");
} else
{
    printf("Send Packet:\r\n");
    DumpPacket(&tSendPkt);
    xSysdeviceGetMBXState(hSys, &ulRecvPktCount, &ulSendPktCount);
    printf("System Mailbox State: MaxSend = %u, Pending Receive = %u\r\n",
          ulSendPktCount, ulRecvPktCount);

    if(CIFX_NO_ERROR != (lRet = xSysdeviceGetPacket(hSys,
                                                    sizeof(tRecvPkt),
                                                    &tRecvPkt,
                                                    PACKET_WAIT_TIMEOUT) )
    {
        printf("Error getting packet from device!\r\n");
    } else
    {
        printf("Received Packet:\r\n");
        DumpPacket(&tRecvPkt);
        xSysdeviceGetMBXState(hSys, &ulRecvPktCount, &ulSendPktCount);
        printf("System Mailbox State: MaxSend = %u, Pending Receive = %u\r\n",
              ulSendPktCount, ulRecvPktCount);
    }
}
}
/* Close the system device */
xSysdeviceClose(hSys);
}

printf(" State = 0x%08X\r\n", lRet);
printf("-----\r\n");

return lRet;
}

```

5.3 Communication Channel Example

```

/*****
/*! Function to demonstrate communication channel functionality
*   Packet Transfer and I/O Data exchange
*   \return CIFX_NO_ERROR on success
*/
*****/
int32_t ChannelDemo(HANDLE hDriver, char* szBoard, uint32_t ulChannel)
{
    HANDLE hChannel = NULL;
    int32_t lRet = CIFX_NO_ERROR;

    printf("----- Communication Channel demo -----\r\n");

    lRet = xChannelOpen(hDriver, szBoard, ulChannel, &hChannel);
    if(CIFX_NO_ERROR != lRet)
    {
        printf("Error opening Channel!");
    } else
    {
        CHANNEL_INFORMATION tChannelInfo = {0};
        CIFX_PACKET          tSendPkt    = {0};
        CIFX_PACKET          tRecvPkt    = {0};
        /* Read and write I/O data (32Bytes). Output data will be incremented each
           cycle */
        uint8_t              abSendData[32] = {0};
        uint8_t              abRecvData[32] = {0};
        uint32_t             ulCycle       = 0;
        uint32_t             ulState      = 0;

        /* Channel successfully opened, so query basic information */
        if( CIFX_NO_ERROR != (lRet = xChannelInfo(hChannel,
                                                sizeof(CHANNEL_INFORMATION),
                                                &tChannelInfo)))
        {
            printf("Error querying system information block\r\n");
        } else
        {
            printf("Communication Channel Info:\r\n");
            printf("Device Number      : %u\r\n", tChannelInfo.ulDeviceNumber);
            printf("Serial Number       : %u\r\n", tChannelInfo.ulSerialNumber);
            printf("Firmware           : %s\r\n", tChannelInfo.abFWName);
            printf("FW Version          : %u.%u.%u build %u\r\n",
                tChannelInfo.usFWMajor,
                tChannelInfo.usFWMinor,
                tChannelInfo.usFWRevision,
                tChannelInfo.usFWBuild);
            printf("FW Date             : %02u/%02u/%04u\r\n",
                tChannelInfo.bFWMonth,
                tChannelInfo.bFWDay,
                tChannelInfo.usFWYear);
            printf("Mailbox Size        : %u\r\n", tChannelInfo.ulMailboxSize);
        }
    }
}

```



```
/* Do a basic Packet Transfer */
if(CIFX_NO_ERROR != (lRet = xChannelPutPacket( hChannel,
                                             &tSendPkt,
                                             PACKET_WAIT_TIMEOUT)))
{
    printf("Error sending packet to device!\r\n");
} else
{
    printf("Send Packet:\r\n");
    DumpPacket(&tSendPkt);

    if(CIFX_NO_ERROR != (lRet = xChannelGetPacket(hChannel,
                                                sizeof(tRecvPkt),
                                                &tRecvPkt,
                                                PACKET_WAIT_TIMEOUT)) )
    {
        printf("Error getting packet from device!\r\n");
    } else
    {
        printf("Received Packet:\r\n");
        DumpPacket(&tRecvPkt);
    }
}
}
```

```

/* Do a basic IO data transfer */
/* Set Host Ready to signal the filed bus an application is ready */
lRet = xChannelHostState(hChannel,
                        CIFX_HOST_STATE_READY,
                        &ulState,
                        HOSTSTATE_TIMEOUT);

if(CIFX_NO_ERROR != lRet)
{
    printf("Error setting host ready!\r\n");
} else
{
    /* Switch on the bus if it is not automatically running (see configuration
    options) */
    lRet = xChannelBusState( hChannel, CIFX_BUS_STATE_ON, &ulState, 0L);
    if(CIFX_NO_ERROR != lRet)
    {
        printf("Unable to start the filed bus!\r\n");
    } else
    {

        /* Do I/O Data exchange until a key is hit */
        while(!kbhit())
        {
            if(CIFX_NO_ERROR != (lRet = xChannelIORead(hChannel,
                                                    0, 0, sizeof(abRecvData),
                                                    abRecvData,
                                                    IO_WAIT_TIMEOUT)))

            {
                printf("Error reading IO Data area!\r\n");
                break;
            } else
            {
                printf("IORead Data:");
                DumpData(abRecvData, sizeof(abRecvData));
                if(CIFX_NO_ERROR != (lRet = xChannelIOWrite(hChannel,
                                                         0, 0, sizeof(abRecvData),
                                                         abRecvData,
                                                         IO_WAIT_TIMEOUT)))

                {
                    printf("Error writing to IO Data area!\r\n");
                    break;
                } else
                {
                    printf("IOWrite Data:");
                    DumpData(abSendData, sizeof(abSendData));
                    /* Create new output data */
                    memset(abSendData, ulCycle + 1, sizeof(abSendData));
                }
            }
        }
    }
}
}
}

```

```
/* Switch off the bus */
xChannelBusState( hChannel, CIFX_BUS_STATE_OFF, &ulState, 0L);
/* Set Host not ready to stop bus communication */
xChannelHostState(hChannel, CIFX_HOST_STATE_NOT_READY,
                    &ulState,
                    HOSTSTATE_TIMEOUT);
/* Close the communication channel */
xChannelClose(hChannel);
}

if(CIFX_NO_ERROR != lRet)
{
    char szBuffer[256] = {0};
    xDriverGetErrorDescription(lRet, szBuffer, sizeof(szBuffer));
    printf(" State = 0x%08X <%s>\r\n", lRet, szBuffer);
} else
{
    printf(" State = 0x%08X\r\n", lRet);
}
printf("-----\r\n");

return lRet;
}
```

5.4 Board and Channel Enumeration

```

/*****
/*! Function to demonstrate the board/channel enumeration
*   \return CIFX_NO_ERROR on success
*/
*****/
void EnumBoardDemo(HANDLE hDriver)
{
    uint32_t          ulBoard      = 0;
    BOARD_INFORMATION tBoardInfo = {0};

    printf("----- Board/Channel enumeration demo -----\\r\\n");

    /* Iterate over all boards */
    while(CIFX_NO_ERROR == xDriverEnumBoards(hDriver, ulBoard, sizeof(tBoardInfo),
                                             &tBoardInfo))
    {
        uint32_t          ulChannel      = 0;
        CHANNEL_INFORMATION tChannelInfo = {0};

        printf("Found Board %.10s\\r\\n", tBoardInfo.abBoardName);
        if(strlen( (char*)tBoardInfo.abBoardAlias) != 0)
            printf(" Alias          : %.10s\\r\\n", tBoardInfo.abBoardAlias);
        printf(" DeviceNumber : %u\\r\\n", tBoardInfo.tSystemInfo.ulDeviceNumber);
        printf(" SerialNumber : %u\\r\\n", tBoardInfo.tSystemInfo.ulSerialNumber);
        printf(" Board ID      : %u\\r\\n", tBoardInfo.ulBoardID);
        printf(" System Error : 0x%08X\\r\\n", tBoardInfo.ulSystemError);
        printf(" Channels     : %u\\r\\n", tBoardInfo.ulChannelCnt);
        printf(" DPM Size      : %u\\r\\n", tBoardInfo.ulDpmTotalSize);

        /* iterate over all channels on the current board */
        while(CIFX_NO_ERROR == xDriverEnumChannels(hDriver, ulBoard, ulChannel,
                                                  sizeof(tChannelInfo), &tChannelInfo))
        {
            printf(" - Channel %u:\\r\\n", ulChannel);
            printf("   Firmware : %s\\r\\n", tChannelInfo.abFWName);
            printf("   Version  : %u.%u.%u build %u\\r\\n",
                tChannelInfo.usFWMajor,
                tChannelInfo.usFWMinor,
                tChannelInfo.usFWBuild,
                tChannelInfo.usFWRevision);
            printf("   Date     : %02u/%02u/%04u\\r\\n",
                tChannelInfo.bFWMonth,
                tChannelInfo.bFWDay,
                tChannelInfo.usFWYear);
            ++ulChannel;
        }
        ++ulBoard;
    }
    printf("-----\\r\\n");
}

```

6 General Protocol Stack Handling

This chapter describes the general usage of the *CIFX API* in conjunction with a fieldbus protocol stack.

6.1 Overview

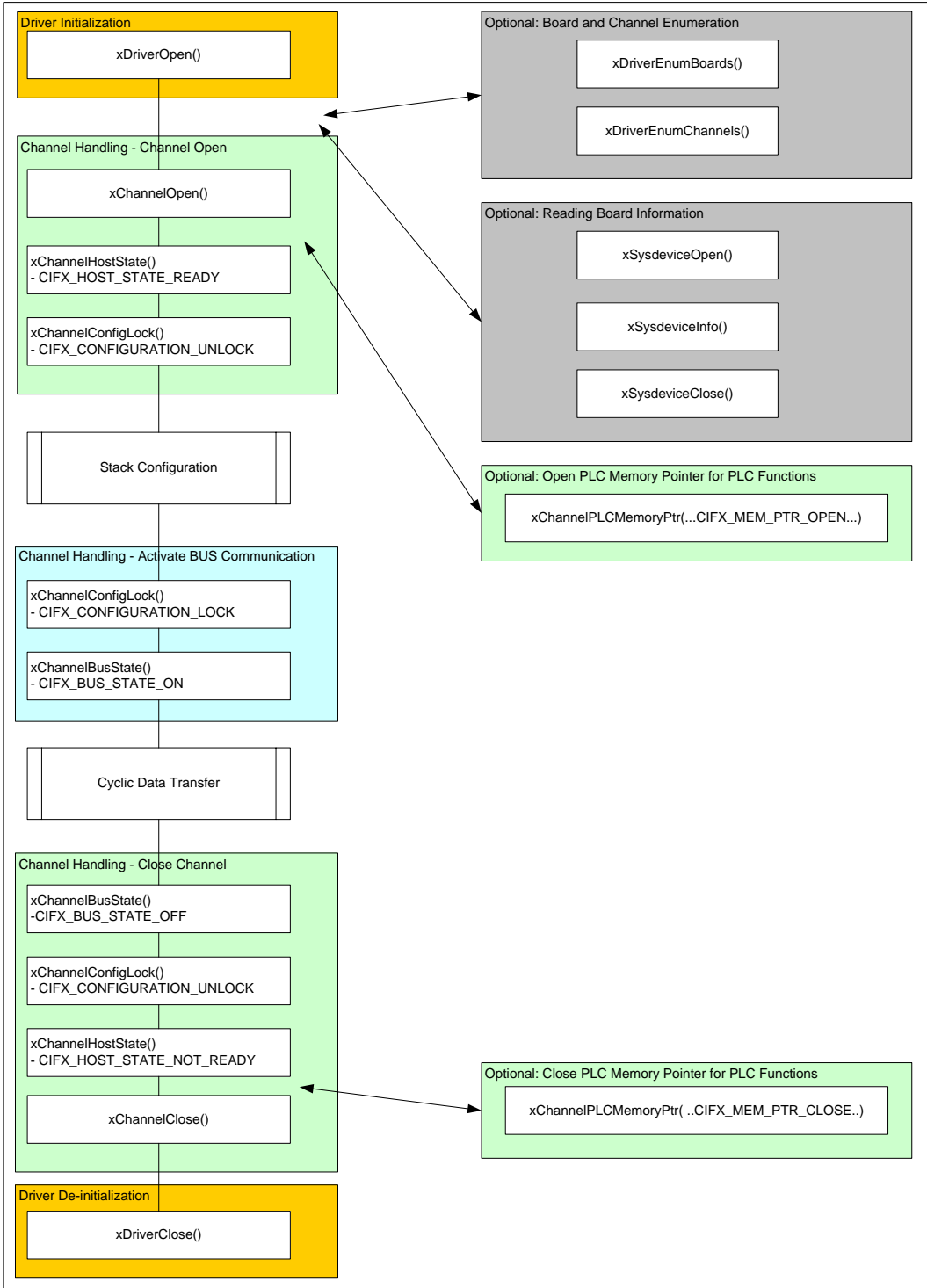

Driver Initialization

- `xDriverOpen()` **Open the Driver**

Reading Driver Information (Optional)

- `xDriverEnumBoards()` **Enumerate all available Boards**
- `xDriverEnumChannels()` **Enumerate channels on a given board**

Reading Board Information (Optional)

- `xSysdeviceOpen()` **Open the system device of a board**
- `xSysdeviceInfo()` **Read board information board via system channel**
- `xSysdeviceClose()` **Close the system channel**

Channel Handling - Open Channel

- `xChannelOpen()` **Open a communication channel**
- **Optional:** Read the channel I/O memory pointers if the PLC functions `xChannelPLC...` are used for I/O data transfer
`xChannelPLCMemoryPtr(...CIFX_PLC_MEM_PTR_OPEN...)`
- `xChannelHostState(...CIFX_HOST_STATE_READY...)` **Signal Application is online**
Wait until channel is READY if the timeout $\neq 0$
Standard Timeout = 1000ms
- `xChannelConfigLock(CIFX_CONFIGURATION_UNLOCK)` **Unlock the configuration**

==> Stack Configuration**Channel Handling - Activate BUS Communication**

- `xChannelConfigLock(...CIFX_CONFIGURATION_LOCK...)` **Locking of the configuration**
- `xChannelBusState(...CIFX_BUS_STATE_ON...)` **Switch BUS to ON**
Timeout $\neq 0$, waits until BUS is ON
Standard Timeout: 5000ms

==> Cyclic Data Transfer**Channel Handling - Close Channel**

- `xChannelBusState(...CIFX_BUS_STATE_OFF...)` **Switch off BUS Communication**
Timeout <> 0, the function waits until the BUS is OFF
Standard Timeout: 5000ms
- `xChannelConfigLock(...CIFX_CONFIGURATION_UNLOCK...)` **Unlock the Configuration**
Unlock the configuration for further changes
- `xChannelHostState(...CIFX_HOST_STATE_NOT_READY...)` **User Application Closed**
Signal the protocol stack, no application is online
- `xChannelClose()` **Close Channel**

Driver De-initialization

- `xDriverClose()` **Close the cifX Driver**

6.2 Protocol Stack Configuration

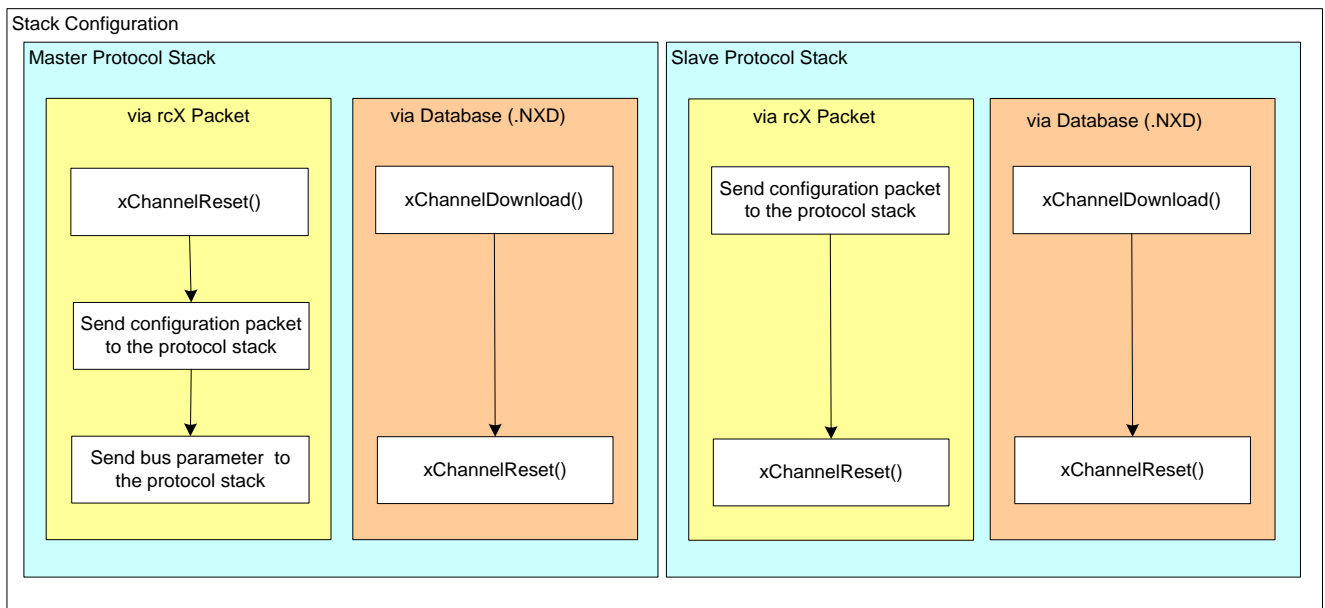

Master Stack Configuration - via rcX Packet

- xChannelReset(...CIFX_CHANNELINIT...) **Deactivate actual configuration**
Maximum Timeout: 10000ms
- Send configuration
This is described in the protocol API manual
- Send Bus Parameter
This is described in the protocol API manual
Configuration is activated automatically after writing the BUS parameters

Master Stack Configuration - via Database

- xChannelDownload(...DOWNLOAD_CONFIGURATION...) **Download a database**
- xChannelReset(...CIFX_CHANNELINIT...) **Activate actual configuration**
Maximum Timeout: 10000ms

Slave Stack Configuration: via rcX Packets

- Send configuration data
- xChannelReset(...CIFX_CHANNELINIT...) **Activate the configuration**
Maximum Timeout: 10000ms
- **Optional:** Set watchdog time (RCX_SET_WATCHDOG_TIME_REQ) via xChannelPutPacket() / xChannelGetPacket())
Standard Put/GetPacket() Timeout: 1000ms

Slave Stack Configuration - via Database

- xChannelDownload(...DOWNLOAD_CONFIGURATION...) **Download a database**
- xChannelReset(...CIFX_CHANNELINIT...) **Activate actual configuration**

Maximum Timeout: 10000ms

6.3 Cyclic Data Exchange

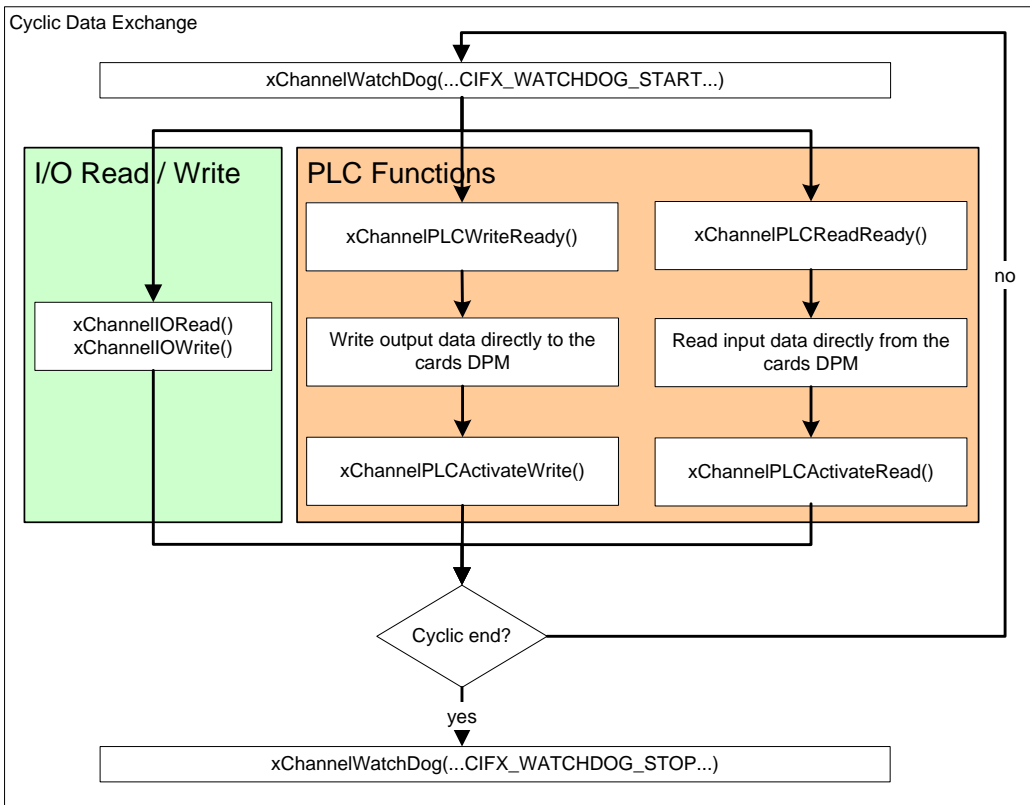

Activate / Trigger Watchdog

- xChannelWatchdog (...CIFX_WATCHDOG_START...) **Activate/Trigger Watchdog**
- **Note:** xChannelWatchdog() must be called, with the parameter CIFX_WATCHDOG_START, within the configured watchdog time.

Using I/O Read/Write Functions

- xChannelIORead() / xChannelIOWrite() **Read / Write I/O Data**

Using PLC Functions

- xChannelPLCIsWriteReady() / xChannelPLCIsReadReady() **Use PLC Functions**
Check if DPM access is allowed
- ... Read / Write data from/to the DPM I/O image areas
- xChannelPLCActivateRead() / xChannelPLCActivateWrite() **Activate I/O Data Transfer**
Activate data transfer (DPM is switched to hardware)

Deactivate Watchdog

- xChannelWatchdog (...CIFX_WATCHDOG_STOP...) **Deactivate Watchdog**

7 Error Codes

Error Code	Symbol / Description
0x00000000	CIFX_NO_ERROR No error

0x800Axxxx	General Error Codes
Error Code	Symbol / Description
0x800A0001	CIFX_INVALID_POINTER Invalid pointer (e.g. NULL was passed to the function)
0x800A0002	CIFX_INVALID_BOARD No board with the given name / index available
0x800A0003	CIFX_INVALID_CHANNEL No channel with the given index available
0x800A0004	CIFX_INVALID_HANDLE An invalid handle was passed to the function
0x800A0005	CIFX_INVALID_PARAMETER Invalid parameter passed to the function
0x800A0006	CIFX_INVALID_COMMAND Command parameter is invalid
0x800A0007	CIFX_INVALID_BUFFERSIZE The supplied buffer does not match the expected size
0x800A0008	CIFX_INVALID_ACCESS_SIZE Invalid access size (e.g. I/O area size is exceeded by given offset and length)
0x800A0009	CIFX_FUNCTION_FAILED Generic function failure
0x800A000A	CIFX_FILE_OPEN_FAILED A file could not be opened
0x800A000B	CIFX_FILE_SIZE_ZERO File size is zero
0x800A000C	CIFX_FILE_LOAD_INSUFF_MEM Insufficient memory to load file a file to RAM
0x800A000E	CIFX_FILE_READ_ERROR Error reading file data
0x800A000F	CIFX_FILE_TYPE_INVALID The given file is invalid for the operation
0x800A0010	CIFX_FILE_NAME_INVALID Invalid filename given
0x800A0011	CIFX_FUNCTION_NOT_AVAILABLE Function is not available on the driver
0x800A0012	CIFX_BUFFER_TOO_SHORT The passed buffer is too short to receive all of the requested data

0x800Axxxx	General Error Codes
Error Code	Symbol / Description
0x800A0013	CIFX_MEMORY_MAPPING_FAILED Error mapping the dual port memory for later memory access
0x800A0014	CIFX_NO_MORE_ENTRIES No more entries available. Returned by enumeration functions (e.g. xDriverEnumBoards(), directories etc.)
0x800A0015	CIFX_CALLBACK_MODE_UNKNOWN Unknown callback handling mode
0x800A0016	CIFX_CALLBACK_CREATE_EVENT_FAILED Failed to create callback events
0x800A0017	CIFX_CALLBACK_CREATE_RECV_BUFFER Failed to create callback receive buffer
0x800A0018	CIFX_CALLBACK_ALREADY_USED Another application has already registered a callback for the given event
0x800A0019	CIFX_CALLBACK_NOT_REGISTERED A callback was not registered before
0x800A001A	CIFX_INTERRUPT_DISABLED Device interrupt is disabled. The executed function expects an enabled hardware interrupt (depending on the driver this must be done either by the device configuration or driver setup program).

Table 18: General Error Codes

0x800Bxxxx	Driver Related Error Codes
Error Code	Symbol / Description
0x800B0001	CIFX_DRV_NOT_INITIALIZED Driver was not correctly initialized during startup or driver is already closed
0x800B0002	CIFX_DRV_INIT_STATE_ERROR Initialization state error. Hardware does not show correct or expected states and information in the DPM after a reset or boot start
0x800B0003	CIFX_DRV_READ_STATE_ERROR Driver read state error
0x800B0004	CIFX_DRV_CMD_ACTIVE The called function is in use by another program instance or application
0x800B0005	CIFX_DRV_DOWNLOAD_FAILED General error during download (e.g. bootloader could not be downloaded or started)
0x800B0006	CIFX_DRV_WRONG_DRIVER_VERSION Wrong driver version
0x800B0030	CIFX_DRV_DRIVER_NOT_LOADED CIFX driver is not loaded / running. Failed to open or start the driver, returned by xDriverOpen()
0x800B0031	CIFX_DRV_INIT_ERROR Failed to initialize the driver
0x800B0032	CIFX_DRV_CHANNEL_NOT_INITIALIZED Channel not initialized (e.g. xChannelOpen() not called)

0x800Bxxxx	Driver Related Error Codes
Error Code	Symbol / Description
0x800B0033	CIFX_DRV_IO_CONTROL_FAILED Function call into the driver failed (e.g. used by the Windows API DLL to signal problems in IO-Control driver calls)
0x800B0034	CIFX_DRV_NOT_OPENED Driver was not opened by calling xDriverOpen()

Table 19: Driver Related Error Codes

0x800Cxxxx	Device / Communication Related Error Codes
Error Code	Symbol / Description
0x800C0010	CIFX_DEV_DPM_ACCESS_ERROR Dual port memory not accessible (e.g. board not found, wrong dual port memory content)
0x800C0011	CIFX_DEV_NOT_READY Device is not ready (NSF_READY or NCF_READY flag is not set) The system device or communication channel is not working
0x800C0012	CIFX_DEV_NOT_RUNNING Device is not running (NCF_RUNNING flag is not set). The communication channel is not configured
0x800C0013	CIFX_DEV_WATCHDOG_FAILED Watchdog test failed
0x800C0015	CIFX_DEV_SYSERR Error in handshake flags
0x800C0016	CIFX_DEV_MAILBOX_FULL Send mailbox is full. The PutPacket() function was not able to write a packet to the device mailbox. Either the mailbox state does not show empty or no more resources on the device available. (NSF_SEND_MBX_ACK / HSF_SEND_MBX_CMD or NCF_SEND_MBX_ACK / HCF_SEND_MBX_CMD flags in wrong state or mailbox counter usPackagesAccepted = 0)
0x800C0017	CIFX_DEV_PUT_TIMEOUT Send packet timeout. The PutPacket() function was not able to write a packet to the device mailbox and the wait time in PutPacket() has expired. Either the mailbox state does not show empty or no more resources on the device available. (NSF_SEND_MBX_ACK / HSF_SEND_MBX_CMD or NCF_SEND_MBX_ACK / HCF_SEND_MBX_CMD flags in wrong state or mailbox counter usPackagesAccepted = 0)
0x800C0018	CIFX_DEV_GET_TIMEOUT Receive packet timeout. GetPacket() function was not able to read a packet from the device and the wait time in GetPacket() has expired. Either the mailbox state does not show a packet available or the device has not sent a packet. (NSF_RECV_MBX_CMD / HSF_RECV_MBX_ACK or NCF_RECV_MBX_CMD / HCF_RECV_MBX_ACK flags in wrong state or mailbox counter usWaitingPackages = 0)
0x800C0019	CIFX_DEV_GET_NO_PACKET No packet available. The GetPacket() function was called with timeout = 0 and the function was not able to read a packet from the device. Either the mailbox state does not show a packet available or the device has not sent a packet. (NSF_RECV_MBX_CMD / HSF_RECV_MBX_ACK or NCF_RECV_MBX_CMD / HCF_RECV_MBX_ACK flags in wrong state or mailbox counter usWaitingPackages = 0)

0x800Cxxxx	Device / Communication Related Error Codes
Error Code	Symbol / Description
0x800C001A	CIFX_DEV_MAILBOX_TOO_SHORT Mailbox is too short for the given packet. The packet sent by PutPacket() does not fit into the mailbox.
0x800C0020	CIFX_DEV_RESET_TIMEOUT Reset command timeout. The device was not reaching READY state, in the given reset timeout, after the application has initiated a reset (RCX_COMM_COS_READY flag not set).
0x800C0021	CIFX_DEV_NO_COM_FLAG Communication flag not set. The fieldbus protocol stack has no communication to the fieldbus devices. Either the cable is disconnected or no other device is connected to the wire (NCF_COMMUNICATING flag not set).
0x800C0022	CIFX_DEV_EXCHANGE_FAILED I/O data exchange failed. Function xChannelIORead() or xChannelIOWrite() fails, because the device does not allow to access the I/O data image. (NCF_PDIN / NCF_PDOUT flags are not in the state allowing access to the I/O process data image)
0x800C0023	CIFX_DEV_EXCHANGE_TIMEOUT I/O data exchange timeout. The given timeout in xChannelIORead() / xChannelIOWrite() expires while the function is waiting to get access to the process data image. (NCF_PDIN / NCF_PDOUT flags are not in the state allowing access to the I/O process data image)
0x800C0024	CIFX_DEV_COM_MODE_UNKNOWN Unknown I/O data exchange mode (mode is not within 0..5)
0x800C0025	CIFX_DEV_FUNCTION_FAILED Device function failed
0x800C0026	CIFX_DEV_DPMSIZE_MISMATCH DPM size differs from configuration, The firmware signals a communication channel size which does not fit into the maximum DPM size defined by the hardware or defined by the user.
0x800C0027	CIFX_DEV_STATE_MODE_UNKNOWN Unknown state mode
0x800C0028	CIFX_DEV_HW_PORT_IS_USED Device is accessed either by another application or another instance. - Driver / device can't be unloaded, open connection to the system device or a communication channels still active - xChannelOpen() can't be executed because it is currently used by another application
0x800C0029	CIFX_DEV_CONFIG_LOCK_TIMEOUT Failed to lock the communication channels configuration within the given time. xChannelConfigLock() wait time expired (RCX_COMM_COS_CONFIG_LOCKED flag not set).
0x800C002A	CIFX_DEV_CONFIG_UNLOCK_TIMEOUT Failed to unlock the communication channel configuration within the given time. xChannelConfigLock() wait time expired (RCX_COMM_COS_CONFIG_LOCKED flag not cleared)
0x800C002B	CIFX_DEV_HOST_STATE_SET_TIMEOUT Wait time expires during xChannelHostState() without reaching CIFX_HOST_STATE_READY. (The function was not able to set the RCX_APP_COS_APP_READY flag or the device has not acknowledged the new status in time)
0x800C002C	CIFX_DEV_HOST_STATE_CLEAR_TIMEOUT Wait time expires during xChannelHostState() without reaching CIFX_HOST_STATE_NOT_READY (The function was not able to clear the RCX_APP_COS_APP_READY flag or the device has not acknowledged the new status in time)

0x800Cxxxx	Device / Communication Related Error Codes
Error Code	Symbol / Description
0x800C002D	CIFX_DEV_INITIALIZATION_TIMEOUT Timeout during device / channel initialization
0x800C002E	CIFX_DEV_BUS_STATE_ON_TIMEOUT Wait time expires during xChannelBusState() without reaching CIFX_BUS_STATE_ON (RCX_COMM_COS_BUS_ON flag not set) Using a timeout, the function will activate fieldbus communication and waits until communication to another fieldbus device is available (NCF_COMMUNICATION flag is set)
0x800C002F	CIFX_DEV_BUS_STATE_OFF_TIMEOUT Wait time expires during xChannelBusState() without reaching CIFX_BUS_STATE_OFF. (The function was not able to clear the RCX_APP_COS_BUS_ON flag or the device has not acknowledged the new status in time and still signals bus communication is active by RCX_COM_COS_BUS_ON).
0x800C0040	CIFX_DEV_MODULE_ALREADY_RUNNING Firmware module (NXO) download and start failed because a module is already running
0x800C0041	CIFX_DEV_MODULE_ALREADY_EXISTS Firmware module (NXO) download was skipped because the module already exists
0x800C0050	CIFX_DEV_DMA_INSUFF_BUFFER_COUNT Number of configured DMA buffers insufficient (at least 8 buffers are expected) Or xChannelDMAState() is used without previously configured DMA buffers.
0x800C0051	CIFX_DEV_DMA_BUFFER_TOO_SMALL DMA buffers size too small (min size 256Byte)
0x800C0052	CIFX_DEV_DMA_BUFFER_TOO_BIG DMA buffers size too big (max size 63,75KByte)
0x800C0053	CIFX_DEV_DMA_BUFFER_NOT_ALIGNED DMA buffer alignment failed (must be 256Byte)
0x800C0054	CIFX_DEV_DMA_HANSHAKEMODE_NOT_SUPPORTED I/O process data exchange mode "uncontrolled" not allowed when DMA transfer is activated
0x800C0055	CIFX_DEV_DMA_IO_AREA_NOT_SUPPORTED I/O process data area index in DMA mode not supported (only area 0 possible)
0x800C0056	CIFX_DEV_DMA_STATE_ON_TIMEOUT Failed to set DMA transfer to "ON" within the given wait time in xChannelDMAState(). (The device has not acknowledged the new status or not set the RCX_COM_COS_DMA flag)
0x800C0057	CIFX_DEV_DMA_STATE_OFF_TIMEOUT Failed to set DMA transfer to "OFF" within the given wait time in xChannelDMAState(). (The device has not acknowledged the new status or not cleared the RCX_COM_COS_DMA flag)
0x800C0058	CIFX_DEV_SYNC_STATE_INVALID_MODE Device is in invalid mode for the command initiated by xChannelSyncState(). The mode must be either "SYNC Host Controlled" (RCX_SYNC_MODE_HST_CTRL) or "SYNC Device Controlled" (RCX_SYNC_MODE_DEV_CTRL)
0x800C0059	CIFX_DEV_SYNC_STATE_TIMEOUT Wait time expired during xChannelSyncState(...,CIFX_SYNC_WAIT_CMD,). Device does not signal the expected synchronization handshake flag state

Table 20: Device / Communication Related Error Codes

8 Appendix

8.1 List of Tables

Table 1: List of Revisions	4
Table 2: Terms, Abbreviations and Definitions	5
Table 3: References to Documents	5
Table 4: List of API Functions – Driver Functions	8
Table 5: List of API Functions – System Device Functions	8
Table 6: List of API Functions – Communication Channel Functions	10
Table 7: Driver Functions	14
Table 8: System Device Functions	15
Table 9: Communication Channel Functions	17
Table 10: Driver Information Structure	18
Table 11: Board Information Structure	18
Table 12: System Channel Information	19
Table 13: System Channel Info Block	19
Table 14: System Channel - Channel Info Block	20
Table 15: System Channel Control Block	20
Table 16: System Channel Status Block	20
Table 17: Channel Information Structure	21
Table 18: General Error Codes	108
Table 19: Driver Related Error Codes	109
Table 20: Device / Communication Related Error Codes	111

8.2 List of Figures

Figure 1: CIFX API Components	6
Figure 2: Component Overview for netX Applications	7
Figure 3: Data Exchange Mode: Buffered Host Controlled I/O	83
Figure 4: Data Exchange Mode: Buffered Device Controlled I/O	84
Figure 5: Bus Synchronization Notifications	86

8.3 Contacts

Headquarters

Germany

Hilscher Gesellschaft für
Systemautomation mbH
Rheinstrasse 15
65795 Hattersheim
Phone: +49 (0) 6190 9907-0
Fax: +49 (0) 6190 9907-50
E-Mail: info@hilscher.com

Support

Phone: +49 (0) 6190 9907-99
E-Mail: de.support@hilscher.com

Subsidiaries

China

Hilscher Systemautomation (Shanghai) Co. Ltd.
200010 Shanghai
Phone: +86 (0) 21-6355-5161
E-Mail: info@hilscher.cn

Support

Phone: +86 (0) 21-6355-5161
E-Mail: cn.support@hilscher.com

France

Hilscher France S.a.r.l.
69500 Bron
Phone: +33 (0) 4 72 37 98 40
E-Mail: info@hilscher.fr

Support

Phone: +33 (0) 4 72 37 98 40
E-Mail: fr.support@hilscher.com

India

Hilscher India Pvt. Ltd.
Pune, Delhi, Mumbai
Phone: +91 8888 750 777
E-Mail: info@hilscher.in

Italy

Hilscher Italia S.r.l.
20090 Vimodrone (MI)
Phone: +39 02 25007068
E-Mail: info@hilscher.it

Support

Phone: +39 02 25007068
E-Mail: it.support@hilscher.com

Japan

Hilscher Japan KK
Tokyo, 160-0022
Phone: +81 (0) 3-5362-0521
E-Mail: info@hilscher.jp

Support

Phone: +81 (0) 3-5362-0521
E-Mail: jp.support@hilscher.com

Korea

Hilscher Korea Inc.
Seongnam, Gyeonggi, 463-400
Phone: +82 (0) 31-789-3715
E-Mail: info@hilscher.kr

Switzerland

Hilscher Swiss GmbH
4500 Solothurn
Phone: +41 (0) 32 623 6633
E-Mail: info@hilscher.ch

Support

Phone: +49 (0) 6190 9907-99
E-Mail: ch.support@hilscher.com

USA

Hilscher North America, Inc.
Lisle, IL 60532
Phone: +1 630-505-5301
E-Mail: info@hilscher.us

Support

Phone: +1 630-505-5301
E-Mail: us.support@hilscher.com