

Serial Communications for INFINITY[®] Meters

Operator's Manual





Additional products from

NEWPORT Electronics, Inc.

Counters	Rate Meters
Frequency Meters	Timers
PID Controllers	Totalizers
Clock/Timers	Strain Gauge Meters
Printers	Voltmeters
Process Meters	Multimeters
On/Off	Soldering Iron
Controllers	Testers
Recorders	pH pens
Relative	pH Controllers
Humidity	pH Electrodes
Transmitters	RTDs
Thermocouples	Thermowells
Thermistors	Flow Sensors
Wire	

For Immediate Assistance

In the U.S.A. and Canada: 1-800-NEWPORT[®]

In Mexico: (95) 800-NEWPORTSM

Or call your local NEWPORT Office.

NEWPORTnetSM On-Line Service

<http://www.newportUS.com>

Internet e-mail

info@newportUS.com

It is the policy of NEWPORT to comply with all worldwide safety and EMC/EMI regulations that apply. NEWPORT is constantly pursuing certification of its products to the European New Approach Directives. NEWPORT will add the CE mark to every appropriate device upon certification.

The information contained in this document is believed to be correct but NEWPORT Electronics, Inc. accepts no liability for any errors it contains, and reserves the right to alter specifications without notice.

WARNING: These products are not designed for use in, and should not be used for, patient connected applications.

PATENT NOTICE: The "Meter Case Bezel Design" is a trademark of NEWPORT Electronics, Inc., registered in the U.S.

PATENT NOTICE: This product is covered by one or more of the following patents: U.S. Pat. No. Des. 336,895; 5,274,577 / Canada 2052599; 2052600 / Italy 1249456; 1250938 / France Brevet No. 91 12756 / Spain 2039150; 2048066 / UK Patent No. GB2 249 837; GB2 248 954 / Germany DE 41 34398 C2. Other International Patents Pending.



This device is marked with the international hazard symbol. It is important to read the Setup Guide before installing or commissioning this device as it contains important information relating to safety and EMC.

Table of Contents

Serial Communications

	Page
SECTION 1	
Introduction	1-1
SECTION 2 HARDWARE	
2.1 Definition of terms	2-1
2.2 RS-232 hardware	2-1
2.3 RS-485 hardware	2-6
SECTION 3 USING THE SETUP AND DATA COMMUNICATION DISKETTES	
3.1 Pushbutton communications setup	3-1
3.2 Diskette-driven computer control	3-2
SECTION 4 DEFINITIONS	
4.1 Meter or DCE	4-1
4.2 Computer or DTE	4-1
4.3 Point-to-point	4-1
4.4 Multipoint (Multi-drop)	4-1
4.5 Simplex	4-1
4.6 Half duplex	4-2
4.7 Full duplex	4-2
4.8 RS-232 (CCITT V.24)	4-2
4.9 RTS	4-2
4.10 RS-422	4-2
4.11 RS-485	4-3
4.12 ASCII	4-3
4.13 HEX-ASCII	4-4
4.14 Transmission voltage levels	4-6
4.15 Recognition Character	4-6
4.16 RAM	4-6
4.17 EEPROM	4-7
SECTION 5 BAUD RATES	5-1
SECTION 6 CHARACTER WAVEFORM	6-1

Free software for NEWPORT devices featuring Ethernet or Serial Communications is on the CD-ROM enclosed with this shipment.
To download the latest software release (or request a free CD-ROM) please go to:
www.newportUS.com/software

	Page
SECTION 7 CLASSES OF OPERATION	
7.1	Point-to-point 7-1
7.1.1	Continuous mode 7-1
7.1.1.1	Message handshake 7-1
7.1.1.2	Character handshake 7-2
7.1.2	Command mode 7-2
7.2	Multipoint 7-2
7.2.1	Command mode 7-2
7.2.2	Alarm mode 7-3
7.3	The meter as a remote display 7-3
7.4	The meter as a double tasking remote meter 7-4
7.4.1	Command structure for double tasking 7-4
SECTION 8 COMMAND AND RESPONSE STRUCTURE	
8.1	Message string 8-1
8.1.1	"DATA" and "NON-DATA" 8-1
8.1.2	Brackets and spaces 8-1
8.2	Commands and structure 8-2
8.2.1	Read communications configuration command 8-2
8.2.2	Normal command structure 8-3
8.2.3	Command formats 8-4
8.2.4	Command suffix 8-5
8.3	Response structure 8-12
8.3.1	No error 8-12
8.3.2	Echo mode 8-12
8.3.3	No echo mode 8-13
8.4	Data length corresponding to the response structure 8-14
8.5	Error response 8-15
8.5.1	Error response format 8-15
8.5.2	Error message 8-15
8.5.3	Description 8-15
8.6	Status character formats 8-18
8.6.1	Alarm status characters 8-18
8.6.2	Peak/valley (HI/LO) status characters 8-20
8.7	"V01" or "External Print" response data format 8-20
8.8	"^AE" response format 8-21
8.9	Examples: temperature/process/strain/universal meters 8-22
8.10	Examples: Rate meter/totalizers 8-24
SECTION 9 METER BUS RESPONSE	
9.1	Point-to-point or multipoint command mode 9-1
9.1.1	Meter's response time 9-1
9.2	Point-to-point continuous mode 9-3

	Page
9.2.1	Meter's response time 9-3
9.2.2	Communicating with the meter when in continuous mode 9-4
9.3	Multipoint Alarm mode response 9-4
9.3.1	Meter's response time 9-5
9.4	External print command 9-5
9.4.1	Meter's response time 9-6
9.5	Watchdog timer for communication 9-7

**SECTION 10 DATA FORMATS ASSOCIATED WITH COMMANDS
("P", "G", "R", "W") PROCESS, STRAIN GAUGE,
TEMPERATURE OR UNIVERSAL METERS**

10.1	Lockout bytes 10-1
10.2	Input type ("INPUT") 10-4
10.3	Reading configuration ("RDG. CNF") 10-6
10.4	Reading, Input, or Output Scale factor ("RD SC", "IN SC", "OUT SC") 10-7
10.5	Reading, Input, or output offset ("RDG OF", "INF OF", "OUT OF") 10-9
10.6	Input configuration ("IN CNF") 10-10
10.7	Setting decimal point location ("DEC PT") and roundoff ("CNT BY") 10-12
10.8	Filter configuration ("FIL.CNF") and number of samples in the average ("FIL TI") 10-13
10.9	Setpoint 1 and 2 configuration ("SP CNF") 10-14
10.10	Alarm (Setpoints 3 and 4) configuration ("AL CNF") 10-15
10.11	Alarm functions ("AL FNC") 10-16
10.12	Alarm delay ("AL RDG") 10-17
10.13	Setpoints 1 and 2 hysteresis ("SP DB") 10-18
10.14	Alarm (SP 3 and SP 4) hysteresis ("AL DB") 10-18
10.15	Output Configuration ("OUT.CNF") and display flashing controls 10-18
10.16	Serial communications configuration ("SER.CNF") 10-19
10.17	RS-485 meter address 10-20
10.18	Data format ("DAT FT") 10-21
10.19	Communications Bus Format ("BUS FT") 10-22
10.20	Number of readings between each transmission ("SER.CNT") .. 10-23
10.21	Recognition character ("SER.RCG") 10-24
10.22	Units-of-measure ("SER.UOM") 10-24
10.23	TX/RX turnaround delay ("SER.DLY") 10-25
10.24	Setpoint value 10-26
10.25	Block read or write 10-27
10.25.1	Block A 10-28

	Page
10.25.2 Block B	10-28
10.25.3 Block C	10-29
10.25.4 Example	10-29

**SECTION 11 DATA FORMATS ASSOCIATED WITH COMMANDS FOR
RATE METER/TOTALIZERS**

11.1 Lockout bytes ("L1 CNF", "L2 CNF", "L3 CNF")	11-1
11.2 Mode	11-3
11.3 Display mode	11-3
11.4 Configuration 1 ("CNFG 1")	11-5
11.5 Configuration 2 ("CNFG 2")	11-6
11.6 Configuration 3 ("CNFG 3")	11-7
11.7 Configuration 4 ("CNFG 4")	11-10
11.8 Average configuration ("AVG.CNF") for rate and square root rate only	11-11
11.9 Measurement time ("GATE T") for rate and square root modes	11-12
11.10 Pulsed setpoint number	11-12
11.11 Alarm time ("AL T")	11-13
11.12 Input Scale and Offset ("IN.SC.OF")	11-13
11.13 Batch decimal point ("BAT DP"), Rate decimal point ("RTE DP"), Total decimal point ("TOT DP")	11-15
11.14 Batch load ("B LOAD"), Batch scale ("BAT SC"), Rate offset ("RTE OF"), Rate scale ("RTE SC"), Total offset ("TOT OF"), Total scale ("TOT SC")	11-16
11.15 Scale operator	11-18
11.16 Setpoint 1 through 4 values	11-18
11.17 Setpoint 5 value	11-19
11.18 Set time ("SET T")	11-19
11.19 Output scale	11-19
11.20 Output offset	11-21
11.21 Raw measurement values; Batch count ("BATCH"), Batch number ("BAT NO"), TOTAL, and TIME	11-22
11.22 Baud rate ("BAUD")	11-24
11.23 Serial communications configuration ("SER.CNF")	11-24
11.24 Data format ("DAT FT")	11-25
11.25 Bus format ("BUS FT")	11-26
11.26 Meter address ("ADDRES")	11-27
11.27 Serial time ("SER T")	11-27
11.28 Recognition character	11-27
11.29 Units of measure	11-28
11.30 Serial delay ("SER.DLY")	11-28

	Page
11.31 Calibration items	11-29
11.32 Block read or write	11-30
11.32.1 Block A (for G, P, R, W commands)	11-31
11.32.2 Block B for batch meter and square-root meter	11-32
11.32.3 Block B for rate meter	11-32
11.32.4 Block C for batch meter only	11-35
11.32.5 Block D for batch meter, square-root and rate meters	11-35
11.32.6 Block E for batch meter, square-root and rate meters	11-36
11.32.7 Example	11-36

INDEX	I-1
--------------------	-----

This page intentionally left blank.

1. Introduction

This guide is intended to facilitate digital communication between your computer (or other controlling device) and one or more meters.

This digital-communications guide is provided for use with any of the meters' OWNER'S GUIDES for Process, Strain gauge, Temperature, Universal, Rate meter/totalizer, Batch controller or Clock, which provide details of all applicable inputs, connections, options, pushbutton controls and programming procedures.

2. Hardware

2

Hardware

2.1 DEFINITION OF TERMS

RX:	Received line on RS-232
TX:	Transmit line on RS-232
RTS:	Request to send
ARX:	First pair received line on RS-422/485 = +RX
ATX:	First pair transmit line on RS-422/485 = +TX
BRX:	Second pair received line on RS-422/485 = -RX
BTX:	Second pair transmit line on RS-422/485 = -TX
GND:	Ground

2.2 RS-232 HARDWARE

INSTALLATION: The RS-232 card is approximately 1" high and 5" long. It is installed with the meter removed from its case (Refer to Section 5 of your meter's Owner's Guide for instructions on how to open the meter). P11 inserts into J11 of the main board located next to the transformer (Refer to Figure 2-1). The board is held in position by a plastic guide on the rear of the display board and plastic assembly at the rear of the meter. The 6-pin telephone jack, P4, is available at the rear of the meter case, and accepts a type RJ-11 or RJ-12 telephone plug (Refer to Figure 2-2).

There are no jumpers on this card; all features are software selectable.

Logic signals are opto-isolated, and drive power is obtained from a galvanically-isolated transformer winding so that the ± 7 V signal levels from the meter can be slaved to the external controller (computer) ground; earthing that ground is recommended.

2

Hardware

You may have either of the following RS-232 boards on hand.

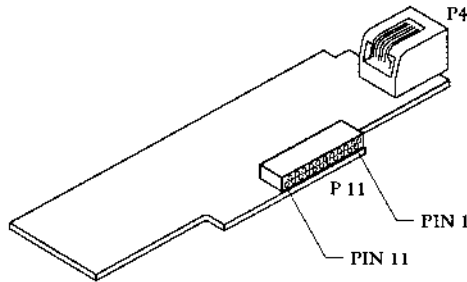

Figure 2-1A. RS-232 Option Board (compatible with AC powered meters only.)

Note: You should install the RS-232 board in such a way the pin "1" of "P11" is aligned with pin "1" of "J11" (on main board, refer to Figure 2-2).

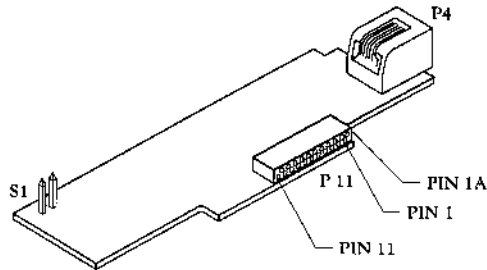

Figure 2-1B. RS-232 Option Board with P11 (12 position)

Note: You should install the RS-232 board in such a way the pin "1" of "P11" is aligned with pin "1" of "J11" (on main board, refer to Figure 2-2). Example: If you have RS-232 board as in Fig 2-1B and "J11" connector on the main board has only 10 pins, then Pin "1A" of the "P11" will be left outside when you install the board onto the "J11".

When interfacing the meter to devices that do not have handshaking lines, i.e. RTS/CTS, the S1-Jumper should be installed. However, when interfacing to a PC, the S1 should be removed.

2

Hardware

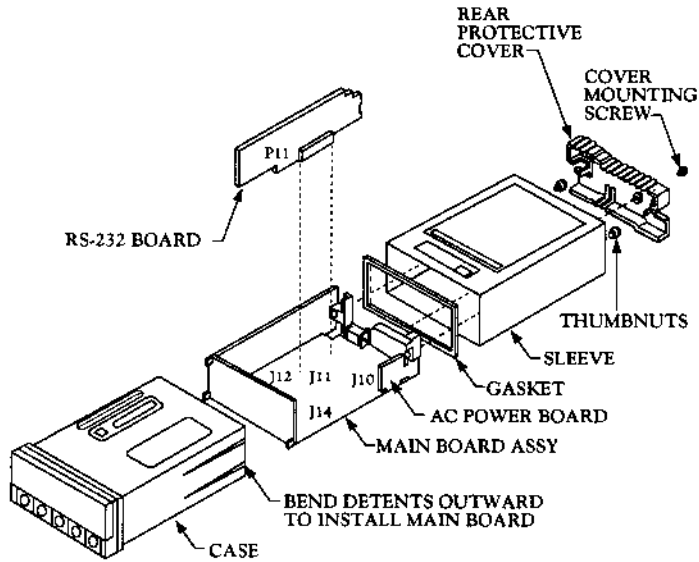

Figure 2-2. Main Board with the RS-232 Option Board

Note: J11 on the main board may have 10 position (1 to 11) or 11 positions (1A to 11).

2

Hardware

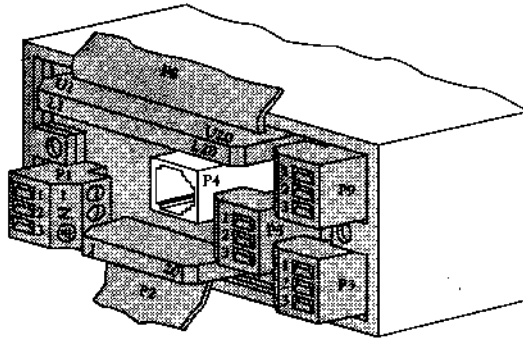

Figure 2-3. Rear of Meter with P4 connection

Figures 2-4A and 2-4B show the four-wire RS-232 connections between the host computer/controller using either a 9-pin or 25-pin "D" connector and the meter (point-to-point full duplex, with RTS handshake).

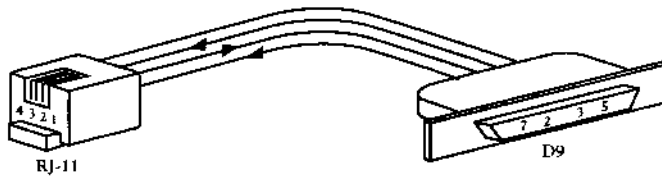

Figure 2-4A. RJ-11 to D9 Connector

2

Hardware



Figure 2-4B. RJ-11 to D25 Connector

Table 2.1 shows the pin connection assignments between the RS-232 connection on the meter and the 9-pin or 25-pin "D" connectors of your computer.

Table 2.1. Meter Hookup to the Computer

PIN SIGNAL/FUNCTION	METER (DCE)		COMPUTER (DTE)	
	RJ-11	RJ-12	D9	D25
RTS, meter from computer	1	2	7	4
TX, meter = RX, computer	2	3	2	3
RX, meter = TX, computer	3	4	3	2
GND	4	5	5	7
NC (not connected)		1,6		(all others)

Table 2.2 shows the pin connection assignments between the RS-232 connection on the meter and the 9-pin or 25-pin "D" connectors of your printer.

2

Hardware

Table 2.2. Meter Hookup to the Printer

PIN SIGNAL/FUNCTION	METER		PRINTER FUNCTIONS
	RJ-11	RJ-12	
RTS, meter	1	2	Data Terminal Ready (DTR)
TX, meter	2	3	Received Data (RXD)
RX, meter	3	4	Not Connected
GND	4	5	Signal Ground
NC (not connected)		1,6	

2.3 RS-485 HARDWARE

The RS-485 card (Refer to Figure 2-5) is the same size and plugs in the same way as the RS-232 card, but there are 3 jumper-selected features. Putting a jumper in S1A adjusts for HALF DUPLEX (see DEFINITIONS in Section 4); a S1B jumper allows for FULL DUPLEX. A jumper in S2 adds an impedance-matching 121 ohms across the HALF DUPLEX lines; for FULL DUPLEX, put a jumper in S3 to impedance-match the other pair of wires.

NOTE: Jumpers S2 or S2 and S3 should be installed only in the meter furthest from the host computer (DTE).

Figure 2-5 shows the card outline and the pin designators for the connectors. For normal RS-485 operation: **remove S4.**

For continuous transmission: install S4 and set BUS format menu item as follows:

BUS.4=0

BUS.5=0

BUS.7=0

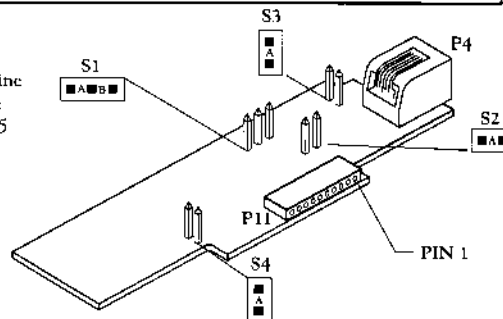

Figure 2-5. RS-485 Option Board

2

Hardware

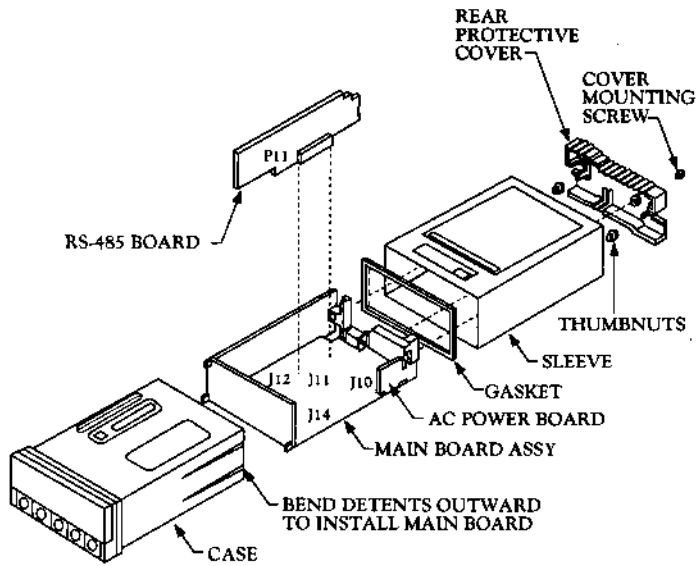

Figure 2-6. Main Board with the RS-485 Option Board

Note: J11 on main board may have either 10 positions (1 to 11) or 11 positions (1A to 11). In the latter case Pin 1A should be outside (not connected).

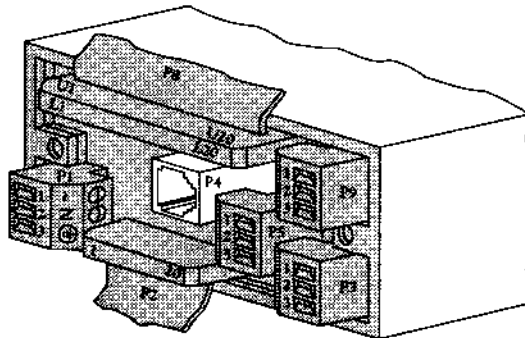

Figure 2-7. Rear of Meter with P4 connection

2

Hardware

Logic symbols are opto-isolated, and drive power is obtained from a galvanically-isolated transformer winding so that the differential signals (minimum ± 2 V) will not be altered by an external ground; earthing of the external transceiver power supply is recommended to limit common-mode voltage.

The RS-485 hardware may be operated point-to-point (e.g., as RS-422 equipment), OR in multipoint, sharing the bus wires with up to 32 other meters.

The RS-485 cabling may be a single pair of wires (usually with a shield) for HALF DUPLEX (Figure 2-8), or two such pairs for FULL DUPLEX (Figure 2-9). The configurations shown are for bus operation, with tap-offs for each meter.

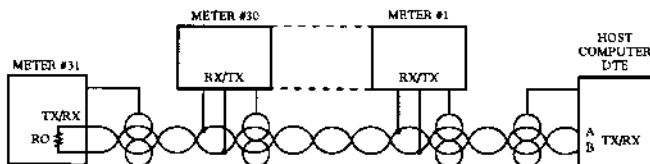

Figure 2-8. Multipoint, Half-Duplex RS-485 Connection

Table 2.3. Half-Duplex Hookup to the Computer

PIN SIGNAL/FUNCTION	METER (DCE) RJ-12	COMPUTER (DTE) D9/D25
A, RX/TX = +RX/TX	1	(SEE MFG DWG)
B, RX/TX = -RX/TX	2	(SEE MFG DWG)
GND	3	(SEE MFG DWG)

RS-422/RS-485 multipoint interconnections between the computer (DTE) and the meter (DCE) are less well defined because different computer/controller manufacturers use different pins on their D9 or D25 connectors.

2

Hardware

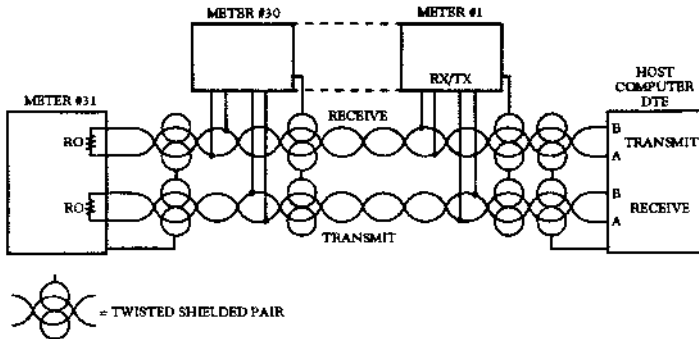

Figure 2-9. Multipoint Full-Duplex RS-485 Connection

Table 2.4. Full-Duplex Hookup to the Computer

PIN SIGNAL/FUNCTION	METER (DCE) RJ-12	COMPUTER (DTE) D9/D25
ATX = +TX	1	(SEE MFG DWG)
BTX = -TX	2	(SEE MFG DWG)
ARX = +RX	4	(SEE MFG DWG)
BRX = -RX	5	(SEE MFG DWG)
GND	3	(SEE MFG DWG)
NC (not connected)	6	

Both HALF DUPLEX (Figure 2-8) and FULL DUPLEX RS-485 (Figure 2-9) communications require a 6-wire RJ-12 plug to be connected to the RJ-12 jack at the rear of the meter.

Unlike RS-232, there presently is no established standard D9 or D25 connector pin-out for RS-485; refer to your computer or controller manual to insure the right cable connections.

NOTE: If communications with your meter has failed, it is recommended that you check for the receive portion of the RS-485 board on DTE (computer). These lines should be pulled up for +RX and pulled down for -RX with resistors with a resistance value from 330 ohms to 1K ohms.

3. Using The Configuration and Communications Diskettes

3

Configuration and Communications Diskettes

NOTE: Configuration and Communications Diskettes are furnished only with the Process, Strain, Temperature, Universal meters. These diskettes are not offered with the rate meter/totalizers, or batch controllers.

The diskettes provide computer-screen prompts for communication setup, control of your meter, and data acquisition.

Although the diskette program provides for selection of many meter features, it is not designed to assist the generation of custom-designed control and data acquisition programs; that information is given starting with Section 4, covering the protocol, coding and format for all of the meter commands and responses.

3.1 PUSHBUTTON COMMUNICATIONS SETUP

Although the diskette program can automatically search for the baud rate, parity and stop-bit settings that have been set into the meter, the search is shorter if these are set to factory preset values via the front-panel pushbuttons.

To enter these values, first unlock the communications bits by setting all "L4 CNF" bits to equal "0".

Next, press the 'MENU' button until "BAUD" is displayed, then press the 'MIN' button to see the previously-set value of the baud rate (nominally "9600"). Press the 'MAX' button to rotate around to this nominal value, unless some other baud rate has been selected.

Now press the 'MENU' button to store this choice and display "SERCNF". Press the 'MIN' button to see "SER.1=0" for no parity, "SER.1=1" for odd parity (the factory preset setting), or "SER.1=2" for even parity. If your computer uses different parity, set the appropriate choice by pressing the 'MAX' button, and advance to "SER.2" by pressing the 'MIN' button.

Free software for NEWPORT devices featuring Ethernet or Serial Communications is on the CD-ROM enclosed with this shipment.

To download the latest software release (or request a free CD-ROM) please go to:
www.newportUS.com/software

3

Configuration and Communications Diskettes

Setting "SER.2=0" picks the factory preset value of one stop bit; setting "SER.2=1" selects two stop bits.

(Note: the combination of no parity and single stop bit has fewer bits than the chosen standard. Therefore, the meter automatically selects two stop bits when you select no parity.)

Pressing the 'MENU' button saves your choices and advances to "ADDRES". This is used to set in an RS-485 device from address 0 to 199 and is accomplished by pressing the 'MIN' button to advance the digit position and pressing 'MAX' button to change values. Note: For RS-232, skip over this by pressing the 'MENU' button.

If the communication link is in place, no more pushbutton programming is needed: the computer takes over at this point. Follow the prompts and selections on that screen.

3.2 DISKETTE-DRIVEN COMPUTER CONTROL

The next three communications bytes will now be set via the communications link. If not already in place, complete the link by plugging in the telephone jack (using the furnished male/male cable and optional computer-card-to-telephone-jack adapter as required). Apply power.

Refer to the DISKETTE instructions and your computer screen. The DISKETTE program will prompt your selections of message format. At the end of this programming, the link will advance your meter to the RUN mode and your measurements will begin.

If the system performance is satisfactory with the diskette-driven controls, you may SKIP the rest of this Guide (which is dedicated to the data needed for custom control and data acquisition program generation).

4. Definitions

This Guide uses some abbreviations and compact wording to signify devices and concepts with detailed descriptions. Significant items are:

4

Definitions

4.1 METER OR DCE

The term "METER" signifies one or more meters (or devices with compatible communications) which respond to the commands (requests) of a controller device such as a computer. Such meters are classified as "DCE" devices, from the older "Data Communication Equipment" telephone specifications.

4.2 COMPUTER OR DTE

These descriptors signify the device controlling the communications, such as a computer ("HOST" device) or programmable controller. Telephony specifications refer to controllers as "Data Terminal Equipment" or DTEs.

4.3 POINT-TO-POINT

Direct connection between two (and only two) devices for data exchange, such as the meter and your digital computer. No addresses are used unless the meter is programmed for a "one-meter bus".

4.4 MULTIPOINT (MULTI-DROP)

Shared wiring for a DTE and more than one DCE, designates a "BUS". Several panel meters and a personal computer can share a bus, with the computer serving as controller. The controller can acquire data by transmitting the preassigned address for a meter followed by a command for the meter to send selected information. When used with the meter, up to 31 meters can share a bus (with addresses from 01 to decimal 199); all meters receive the data when the address is "00".

4.5 SIMPLEX

A channel (path, typically a twisted pair of wires) with unidirectional data flow.

4

Definitions

4.6 HALF DUPLEX

A channel (e.g., twisted pair) with bi-directional data flow, but only in one direction at a time.

4.7 FULL DUPLEX

Two channels (e.g., two twisted pairs) with bi-directional data flow at any time (one simplex channel in each direction).

4.8 RS-232 (CCITT V.24)

Bipolar ± 5 to ± 15 V point-to-point transmission for short distances and moderate data rates. The meter operates with full-duplex RS-232, with two wires (RX and TX), plus a common ground, to transmit baud in either direction. A third signal wire, Request To Send, is referenced to the same ground wire and is used by the computer (DTE) to control transmissions of the meter (DCE).

Receiver sensitivity is ± 3 V and impedance of 3 to 7 kilohms. (Although RS-232 is nominally for only one driver and one receiver on the line, custom high-impedance versions exist for limited multipoint use.)

4.9 RTS

A designator for the "Request To Send" control signal from the computer, carried on a wire separate from that of the data, and used by the meter to permit or inhibit transmissions in Continuous Mode RS-232. The other control line of RS-232, CTS, is not used in meter communications.

4.10 RS-422

Unipolar-voltage (3.6 to 6 V supplies) simplex drive of a bus with ± 2 V-differential signals (neither wire at ground) for long distances and/or high data rates. Receiver sensitivity 200 mV, common-mode voltage range ± 3 V, and impedance 4 kilohms or more. A maximum of one driver and 10 receivers allowed, with no driver protection against bus contention. Duplex operation requires another set of hardware.

4.11 RS-485

This is the extension of RS-422 to a half or full duplex bus of up to 32 devices, with multiple drivers and driver-contention protection. Receiver impedance is now 12 kilohms or more.

4.12 ASCII

Table 4.1 shows the ASCII (American Standard Code for Information Interchange) symbols which can be encoded in a 7-bit binary code (DB0 through DB6). When organized in table form, these 7 bits may be regarded as the symbol address, the most significant 3 bits determining the column and the last four bits determining the row.

These symbols include all the decimal numerals, letters, punctuation marks, common abbreviations and control characters, including non-printed symbols such as Carriage Return and Line Feed.

The 7-bit symbol code (or address) is called a "character", and digital communication with the meter is made with a string of these characters.

When transmitted, each character is preceded by a start bit (BAUD) and followed by one or two stop bits plus an optional parity bit, making a train of 10 or 11 baud for each transmitted character. If you are building a system from the UART up (Universal Asynchronous Receiver/Transmitter), that device must be informed of the number of data bits, parity, stop bit length, etc., so that it properly decodes the incoming stream into the bytes that your program can recognize (check the UART or plug-in board literature for required control signals).

As dictated by FORMAT statements, a symbol may be sent by transmitting just its table address (one character, plain ASCII) or by HEX-ASCII, which uses two characters, one for each of the two hex address nibbles (0 through 7 for the column nibble, 0 through F for the row nibble, shown on top and left-hand side of Table 4.1).

4

Definitions

4.13 HEX ASCII

Storage in most digital devices is in groups of 8 bits, called bytes. Each byte has a most-significant nibble (the left most 4 bits) and a least-significant nibble.

To make the best use of the available storage, all possible bit sequences should be used, so each nibble can have 16 different values (not just the ten of decimal notation). These 16 values are symbolized by 0-9 and A-F, the hexadecimal code.

The meter transmits almost all data (shown in format statements as <data>) in this HEX-ASCII form: each byte is broken into its two nibbles, each nibble is given its HEX symbol, and the ASCII character (table address) for each of those two HEX symbols is then transmitted (most significant nibble first).

The transmitter and receiver must know whether a number or a non-numerical symbol is being sent by HEX-ASCII: this is the reason for standard FORMATS in the meter commands and responses. To illustrate this requirement, if you decode two adjacent characters as "0110100" (the code for the symbol "4") and "1000001" (the code for the symbol "A"), do you print "4A" or do you print the symbol whose hex table address is 4A, the letter "J"? The format statements tell you which is which.

The responses to "V" and "X" commands encode the numerical <data> in HEX-ASCII, but use decimal (BCD) nibbles (4 bits per decimal digit), storing these two BCD digits per byte (rather than 8 bits of straight binary). Decoding to decimal is then simplified for receiving devices such as printers.

"V" and "X" commands also use a single plain ASCII character for each ".", ",", and units-of-measure symbols, in contrast to the "G, P, R or W" commands and responses, which encode everything in HEX-ASCII, 2 characters to the byte.

Table 4.1. The ASCII Character Code

							COL	0	1	2	3	4	5	6	7	
							DB6=	0	0	0	0	1	1	1	1	
							DB5=	0	0	1	1	0	0	1	1	
							DB4=	0	1	0	1	0	1	0	1	
ROW																
H E X	D E C	D B 3	D B 2	D B 1	D B 0											
0	0	0	0	0	0		NUL	DLE	SP	0	@	P	'	p	.	
1	1	0	0	0	1		SOH	DC1	!	1	A	Q	a	q		
2	2	0	0	1	0		STX	DC2	"	2	B	R	b	r		
3	3	0	0	1	1		ETX	DC3	#	3	C	S	c	s		
4	4	0	1	0	0		EOT	DC4	\$	4	D	T	d	t		
5	5	0	1	0	1		ENQ	NAK	%	5	E	U	e	u		
6	6	0	1	1	0		ACK	SYN	&	6	F	V	f	v		
7	7	0	1	1	1		BEL	ETB	'	7	G	W	g	w		
8	8	1	0	0	0		BS	CAN	(8	H	X	h	x		
9	9	1	0	0	1		HT	EM)	9	I	Y	i	y		
A	10	1	0	1	0		LF	SUB	*	:	J	Z	j	z		
B	11	1	0	1	1		VT	ESC	+	;	K	[k	{		
C	12	1	1	0	0		FF	FS	,	<	L	\	l			
D	13	1	1	0	1		CR	GS	-	=	M]	m	}		
E	14	1	1	1	0		SO	RS	.	>	N	^	n	-		
F	15	1	1	1	1		SI	US	/	!	O	_	o	DEL		

Non-numeric symbols (e.g., letters) or unprinted characters that are sent in hex data strings are transmitted as the two characters of their hex address; e.g., "*" is "2A", Carriage Return is "0D", Line feed is "0A", XON=DC1 is "11", and XOFF=DC2 is "13".

4

Definitions

4

Definitions

4.14 TRANSMISSION VOLTAGE LEVELS

The voltage levels accepted by the meter are those of the standards, and the meter outputs are well regulated and well within the standards. The two wires carrying the signal are designated "A" and "B"; for RS-232, "B" is taken as the 0 V ground.

Table 4.2. Meter Receiving Voltages

OPTION TYPE	"1" BIT/MARK OR STOP BIT	"0" BIT/SPACE OR START BIT
RS-232 RS-422 or 485	$-3 > A > -15 \text{ V}$ $A < (B-0.2 \text{ V})$	$+3 < A < +15 \text{ V}$ $A > (B+0.2 \text{ V})$

Table 4.3. Meter Transmitting Voltages

OPTION TYPE	"1" BIT/MARK OR STOP BIT	"0" BIT/SPACE OR START BIT
RS-232 RS-422 or 485	$-6 > A > -7 \text{ V}$ $A < (B-2 \text{ V})$	$+6 < A < +7 \text{ V}$ $A > (B+2 \text{ V})$

The RS-422/485 transmissions from the meter are 3-state, and both receive and transmit are zener-protected.

4.15 RECOGNITION CHARACTER

A selectable symbol (e.g., the asterisk, *) transmitted as the first character of each message from the computer, which is used for message security: the meter ignores messages without this symbol.

4.16 RAM

The acronym for "Random Access Memory". For the meter, the storage for the data and instructions for the immediately-occurring operation. When given a "RESET1" or "soft" reset, the meter restarts its operation from the data in RAM. "PUT" commands insert information from the computer into RAM, and "GET" commands transmit RAM information to the computer.

4.17 EEPROM

The acronym for "Electrically Erasable Programmable Read-Only Memory". For the meter, the non-volatile memory for the setup and configuration data is retained independent of power or resets. Upon a "RESET2" or "hard" reset (e.g., after any BLOCK WRITE command), the data in the EEPROM is copied into RAM, discarding whatever data had been running. "WRITE" commands insert information from the computer into EEPROM, and "READ" commands transmit EEPROM data to the computer.

4

Definitions

5. Baud Rates

The meter can operate at any rate from 300 to 19,200 in 2:1 steps.
Following are the baud rates used by the meter:

300, 600, 1200, 2400, 4800, 9600, and 19200.

5

Baud Rates

6. Character Waveform

Ten or eleven bits are used for each character: a start bit, 7 bits for the ASCII character, one parity bit, and either one or two stop bits. If the parity bit is chosen as "none" (absent), the stop length is automatically set at two bits by the meter (to keep the minimum character length to ten bits).

Figure 6-1 shows the mark/space sequence.

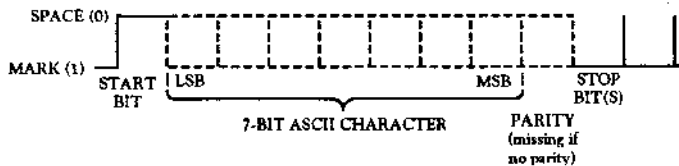

6
Character
Waveform

Figure 6-1. Character Waveform

The rising edge of the start bit of the next character may occur at any time after the end of the last stop bit.

Notes:

6

Character
Waveform

A series of 20 horizontal lines for writing notes, arranged in a vertical column on the right side of the page.

7. Classes of Operation

There are two (2) classes of operation associated with meter serial communications: Point-to-point and Multipoint. (Refer to Section 10.19 for Process, Temperature, Strain Gauge and Universal meters and Section 11.25 for Rate Meter, Totalizer and Batch meters.)

7.1 POINT-TO-POINT

No device address is included in the command or response message when operating in this class. There are two (2) modes associated with this class; CONTINUOUS and COMMAND.

7.1.1 CONTINUOUS MODE

For RS-232, the computer can direct the meter to repeatedly transmit the data and status information in the format specified by the communications setup (which includes a selectable parameter to space out the transmissions for data logging purposes).

Continuous mode is not used on RS-422/485, because no RTS line is present to prevent bus contention. However, you can use one meter using a RS-485 board by configuring the meter for point-to-point continuous mode, and configure it so that it is enabled at all times. This will result in allowing for transmission to be sent for longer distances to such devices as large remote displays.

Control of the continuous mode is by RTS level. Either message or character control can be specified. In the former case, RTS polarity is checked by the meter before a message is begun, but, once started, the transmission continues to the end of the specified message. In the latter case, RTS polarity is checked before each character transmission, so that the meter message can be interrupted after any character.

The specified data and status are transmitted for each new measurement (if so requested), provided that the selected baud rate and message length are adequate. If the message transmission takes longer, complete messages are sent as fast as possible, skipping any readings overlapped by a message transmission.

7.1.1.1 MESSAGE HANDSHAKE

The RTS line from the host controller is checked when the device is ready to send measurement data. If the RTS is true, it sends the

7

Classes of
Operation

7

Classes of
Operation

complete message data without interruption even if RTS goes false in the middle of transmission. If RTS is false, it skips sending the data completely and continues with the next measurement.

7.1.1.2 CHARACTER HANDSHAKE

The device checks the RTS input before sending each character and sends characters only while RTS is true. It always completes sending the data before transferring the latest reading to the output buffer.

7.1.2 COMMAND MODE

In this mode, no handshake line is used, but instead a simple command from the host requests that the device transmit its latest measurement message.

7.2 MULTIPOINT

A device address from 0 to 199 is included in the COMMAND or RESPONSE message. By using the addressing capabilities, collision on the bus can be avoided. If "00" is used for the address on multiple units, they will all receive the COMMAND but will not respond. This is used to avoid collisions on the bus. There are two (2) modes available in the class; COMMAND MODE and ALARM MODE.

NOTE: NO RTS handshaking is available with Multipoint.

7.2.1 COMMAND MODE

Each device, when it receives an addressed command, checks the received address. If it matches its own pre-selected address, the device responds by fulfilling the command. After a programmed turnaround delay time, it may transmit either an acknowledgement and/or the requested data, or may have no response. If the address does not match, the command is ignored. The programmed turnaround time delay allows for line reflections to dissipate and for the transmitting host controller to switch to the receive mode. The turnaround time delay choices are 0, 30, 100 and 300 milliseconds with a 3 ms uncertainty.

7.2.2 ALARM MODE

All devices can be put into the alarm mode simultaneously by a single address 00 command. In the alarm mode, the bus is quiet until one of the devices detects an alarm condition. It then transmits its address onto the bus and goes out of the alarm mode. When other devices detect a character on the bus, they too go out of the alarm mode. The host program, which may have been performing an unrelated task, is then interrupted by receipt of a character and after a short delay, starts polling all devices. It begins with the received address device. All devices are polled in case two or more have reached an alarm condition at or near the same time. If this happens, it can cause bus contention, corrupted characters or framing errors. However, none of these result in system failure because any bus activity causes all devices to exit the alarm mode and the host program to perform the alarm poll. After identifying the alarm device(s), the alarm can be reset and the host controller can put the devices back into the alarm mode. It is suggested that the host controller polls all of the devices when ready to send the common alarm mode and sends it only if all alarms are inactive. This reduces the probability of two or more devices being ready to transmit on the bus simultaneously when the alarm mode is entered due to existing alarm conditions.

7.3 THE METER AS A REMOTE DISPLAY

NOTE: The Remote Display Mode pertains only to the Process, Strain Gauge, Temperature and Universal meters. This feature is not available in the Rate meter/Totalizer or Batch controller units.

The meter has the capability to become a remote display. While in this mode, it can accept any word with 1 to 6 letters (7 including one decimal point). Valid characters are: numbers from 0-9, uppercase letters from A-Z, space, period, “/”, “-”, “+”, “.” and “*”. Upon receiving the proper command from the host controller, the meter will switch to the REMOTE DISPLAY mode and display whatever has been transmitted to it.

NOTE: The meter will continue to operate normally during this mode.

As an example, try to write “Hello my name is Bob” to the meter number 25 decimal (19 hex) on the RS-485 network. Assume “*” is the meter’s recognition character.

7

Classes of
Operation

Transmit according to the following steps:

- 1) *19Y01HELLO<CR>
- 2) *19Y01MY<CR>
- 3) *19Y01NAME<CR>
- 4) *19Y01IS BOB<CR>

(You would want to generate a proper delay between each step.)

To go back to "RUN" mode, use the following command:

*19D03<CR>

(See Section 8 for more information on commands).

7.4 THE METER AS A DOUBLE TASKING REMOTE METER

The Process, Strain Gauge, Temperature and Universal meters can be configured as a double tasking remote indicator/controller. This is accomplished by transmitting any value (In HEX format Only!) from "-99999 to 999999" (and any decimal point position between 1 to 6) to the meter. The value transmitted will be the meter's Reading Value which allows you to display any value desired and assign a setpoint as well as set up the value of this setpoint. The meter can also be configured to output this value via the optional analog or BCD output boards. The double tasking is accomplished during this operation, the meter will continue to operate normally and the Filtered Value is the value used for normal operation.

NOTE: For comparing the transmitted value with any setpoint, the decimal point of the value should be equal to the meter's decimal point position.

7.4.1 COMMAND STRUCTURE FOR DOUBLE TASKING

The general command structure for this mode is as follows:

*[nn]Y02<DATA><CR>

Where: * = The recognition character
nn = Device address (Required for multipoint mode only)
Y02 = Command index
DATA = 3 byte Hexadecimal based (24 bits) value as:

1) First 20 bits are the absolute value (Maximum is 999999 when positive and 999999 when negative)

2) Bits 21, 22, 23 are assigned to the decimal point as shown below:

BIT NO.			DECIMAL VALUE*
23	22	21	
0	0	0	Not used
0	0	1	-0
0	1	0	-1
0	1	1	-2
1	0	0	-3
1	0	1	-4
1	1	0	-5
1	1	1	Not used

*10 to the power of the value

3) Bit 24 is the polarity sign
0 = Positive
1 = Negative

EXAMPLE: To send a value of "-23.468" to the meter, you must first send the meter number which is 15 HEX with "*" as the recognition character. The following is the itemized list of the required variables that must be sent via HEXADECIMAL:

Absolute value is 23468 and its HEX equivalent is "5BAC"
Decimal value will be "100 BINARY" and HEX equivalent is "4HEX".

Sign is negative and must be sent as "1" and therefore bits 21, 22, 23, and 24 (or most significant nibble) will be 1100 binary or "C" HEX. Combine this with value and you have "DATA" with a Hexadecimal equivalent of "C05BAC".

The complete command for this example is as follows:
"*15Y02C05BAC<CR>"

7

Classes of
Operation

8. Command and Response Structure

8.1 MESSAGE STRING

8.1.1 "DATA" AND "NON DATA"

Each of the many types of messages between computer or printer and the meter is transmitted or received as a string of ASCII characters. These characters are classified as "DATA" and "NON DATA".

"DATA" is the string of measurement or non-measurement values (see Sections 8.2 and 8.3) and can be classified as:

1. <data>: hexadecimal based values. Each nibble is converted to the ASCII character and transmitted or received.
2. <data>: is alphanumeric plain ASCII characters and need not be converted. It is used in Remote Display Mode.
3. <value> is data which is transmitted against "X", "V01" or external print commands. These are in decimal base, and each digit is converted to the ASCII character and transmitted along with decimal point and sign.

"NON DATA" items are: recognition character(*), device address (nn), command prefix letter (c), command suffix (cc), space (S or SP), carriage return (CR), line feed (LF), checksum (hh), and units of measure (uuu). Checksum, device address, and command suffix (cc) items are hexadecimal base, and each nibble will be converted to the ASCII character and transmitted. The rest of the "NON DATA" items are plain ASCII characters and need not be converted (see examples in Section 8.8).

8.1.2 - BRACKETS AND SPACES

In the following text the position reserved for each ASCII character is represented by a lower-case letter.

If there must always be an ASCII character put into the message at that position, no brackets are used.

8

Command
and
Response
Structure

Angle brackets, "<" and ">", are used to enclose names (or acronyms). In the actual message these names will be replaced by the ASCII value of that name (the number of those ASCII characters is not usually the same as the number of letters of the name inside the angle brackets).

The occurrence of non-printing ASCII characters is also indicated by angle brackets (e.g., "<CR>").

Square brackets, "[" and "]" enclose items which are optional, i.e., the message is still valid when those are omitted.

8.2 COMMANDS AND STRUCTURE

The meter responds to over 150 different commands from the computer. This section gives the format and lists all commands by COMMAND CLASS and COMMAND SUFFIX.

8.2.1 READ COMMUNICATIONS CONFIGURATION COMMAND

To have the meter report its current communication parameters, the special command "^AE" is provided when transmitted to the meter with the correct baud rate, parity information, stop bit(s), and address (if multipoint). The meter will return 4 bytes (9 characters including carriage return) of information as follows:

Byte #1 = Recognition character
Byte #2 = Meter address
Byte #3 = Bus Format
Byte #4 = Communications configuration

NOTE: This "READ ONLY" command is the only one without a leading recognition character.

Command Format:

^AE<CR> for point-to-point,
 or
^AE[nn]<CR> for multipoint

where nn = device address from 01 to C7 (hex) = 01 to 199 decimal.

NOTE: Response detail is given in Sections 8.8 and 8.9.

8.2.2 - GENERAL COMMAND STRUCTURE

The meter can be commanded to “read”, i.e., to transmit (send) data from either the nonvolatile memory (EEPROM) or from the volatile working memory (RAM). The meter can also be commanded to “write”, i.e., store new values for data processing or meter control.

There are different command types associated in communicating with your meter as follows:

Type (1) Commands which return non-measurement data from the meter are “R” and “G”.

Type (2) Commands which return measurement data from the meter are “X” and “V”.

Type (3) Commands which return status character data from the meter is “U”.

Type (4) Commands which send non-measurement data to the meter are “P”, “W”, and “Y” (For Process, Strain Gauge, Temperature and Universal meters only).

Type (5) Commands for disable, enable, and reset are “D”, “E”, and “Z”.

8

Command
and
Response
Structure

Table 8.1. Command Prefix Letters (Command Classes)

COMMAND PREFIX (COMMAND CLASS)	MEANING
^AE	Special read, communications parameters
P (Put)	Write HEX data into RAM
W (Write)	Write HEX data into EEPROM
G (Get)	Read HEX data from RAM
R (Read)	Read HEX data from EEPROM
U	Read status byte
V	Read measurement data string in decimal format
X	Read measurement data values in decimal format
D	Disable
E	Enable
Z	Reset
Y (temp/process/strain meters only)	Write characters or values to the meter

8.2.3 - COMMAND FORMATS

For "P" and "W" Command classes:

- a) Point-to-point mode:
*ccc<data>[hh]<CR>
- b) Multipoint mode:
*nnccc<data>[hh]<CR>

For "G" and "R" Command classes:

- a) Point-to-point mode:
*ccc[hh]<CR>
- b) Multipoint mode:
*nnccc[hh]<CR>

For "X", "V", "U", "D", "E", and "Z" Command classes:

- a) Point-to-point mode:
*ccc[hh]<CR>
- b) Multipoint mode:
*nnccc[hh]<CR>

For "Y" Command (Process, Strain Gauge, Temperature and Universal meters only):

Remote Display

- a) Point-to-point mode:
*Y01<data><CR>
- b) Multipoint mode:
*nnY01<data><CR>

Remote Indicator Controller

- a) Point-to-point mode:
*Y02<data><CR>
- b) Multipoint mode:
*nnY02<data><CR>

continued next page

Where "*" is the selected Recognition Character, you may select any ASCII table symbol from "!" (hex address "21") to the right-hand brace (hex "7D") except for the caret "^", "A", "E", which are reserved for bus format request.

"[nn]" are the two ASCII characters for the device Bus Address. Use values from "00" to hex "C7" (199 decimal).

"ccc" stands for the HEX-ASCII COMMAND CLASS letter (one of twelve given in Table 8.1), followed by the two HEX-ASCII COMMAND SUFFIX characters identifying the meter data, features or menu items to which the command is directed (given in Table 8.2).

"<data>" is the string of characters containing the variable information the computer is sending to the meter. These data (whether BCD or binary) are encoded into HEX-ASCII characters, two characters to the byte, except for the "Y01", "write to the display" command: here, the desired display upper-case letters, numbers or (limited) symbols are transmitted by plain ASCII characters. Square brackets (indicating optional status) enclose this <data> string, since some commands contain no data.

"[hh]" is the optional CHECKSUM BYTE, two HEX-ASCII characters equal to the modulo 256 sum of all the preceding bytes including the serial recognition character. Each addition to this sum uses the ASCII 7 bits plus the parity bit as the most-significant bit. Any carry (overflow) bits are discarded. The checksum is transmitted most-significant character first.

Message errors can be discovered by computing the checksum from the received bytes and comparing that total with the transmitted checksum. However, most systems have a good signal-to-noise ratio, so that checksum errors are rare and the procedure is infrequently used.

8.2.4 - COMMAND SUFFIX

The two HEX characters following the command class letter are used to specify the data, features or menu items which the command affects. Table 8.2 gives the command letter, suffix, feature affected, and the number of data characters included in the command.

"00" is not used (reserved for the all-device bus address).

8

Command and Response Structure

8

Command
and
Response
Structure

Table 8.2. Command Letters and Suffixes for Temperature/Process/Strain/Universal Meters

COMMAND	SUFFIX	ITEM AFFECTED	# CHAR	SECTION
D	01	Disable Alarms (SP#3 and SP#4)	0	8.2.3
E	01	Enable Alarms (SP#3 and SP#4)	0	8.2.3
R,W	01	L1 CNF, Lockout byte #1	2	10.1
U	01	Setpoints and Alarm Status	0	8.2.3
V	01	Read Data String	0	8.2.3
X	01	Read Unfiltered Value	0	8.2.3
Y	01	Write value to display	6	8.2.3
Z	01	Reset latched alarms	0	8.2.3
D	02	Disable setpoints 1 and 2	0	8.2.3
E	02	Enable setpoints 1 and 2	0	8.2.3
R,W	02	L2 CNF, Lockout byte #2	2	10.1
U	02	Peak/Valley (HI/LO) status	0	8.2.3
X	02	Read Peak (HI) value	0	8.2.3
X	Y02	Write value to meter	7	8.2.3
Z	02	Reset averaging filter	0	8.2.3
D	03	Disable display of remote value	0	8.2.3
E	03	Set alarm mode	0	7.2.2
R,W	03	L3 CNF, Lockout byte #3	2	10.1
U	03	Microprocessor Revision	0	8.2.3
X	03	Read Valley (LO) value	0	8.2.3
Z	03	Soft Reset (RESET1, from RAM)	0	8.2.3
D	04	Hold displayed value	0	8.2.3
E	04	Display "RUN"	0	8.2.3
R,W	04	L4 CNF, lockout byte #4	2	10.1
X	04	Read filtered value	0	8.2.3
Z	04	Hard Reset (RESET2, from EEPROM)	0	8.2.3
D	05	Reset tare, valid only on strain meter	0	8.2.3
E	05	TARE, valid only on strain meter	0	8.2.3
G,P,R,W	05	INPUT, type and range	2	10.1
Z	05	Reset Peak/Valley (HI/LO)	0	8.2.3
G,P,R,W	07	RDG CNF, display controls	2	10.3
G,P,R,W	08	RDG SC, display scale factor	6	10.4
G,P,R,W	09	RDG OF, display offset	6	10.5
G,P,R,W	0A	IN CNF, meter features	2	10.6
G,P,R,W	0B	INP SC, input scale factor	6	10.4
G,P,R,W	0C	DEC PT and CNT BY (roundoff)	2	10.7
G,P,R,W	0E	FIL CNF and FIL TI, filter #s	2	10.6

(continued next page)

(continued from previous page)

COMMAND	SUFFIX	ITEM AFFECTED	# CHAR	SECTION
G,P,R,W	10	SP.CNF, control setpoints 1 and 2	2	10.9
G,P,R,W	11	AL.CNF, control setpoints 3 and 4	2	10.10
G,P,R,W	12	AL.FNC, alarm function	2	10.11
G,P,R,W	13	AL.RDG, # readings delayed	2	10.12
R,W	14	SP.DB, setpoint hysteresis	4	10.13
R,W	15	AL.DB, alarm hysteresis	4	10.14
G,P,R,W	16	OUT.CNF, analog out and flashing	2	10.15
G,P,R,W	17	OUT.SC, analog out scale	6	10.4
R,W	18	SER.CNF, communications configuration	2	10.16
G,P,R,W	1A	ADDRES, RS-485 device # address	2	10.17
G,P,R,W	1B	DAT.FT, communication data format	2	10.18
G,P,R,W	1C	BUS.FT, communications BUS format	2	10.19
R,W	1D	SER.CNT, # of readings between each transmission	4	10.20
G,P,R,W	1E	SER.RCG, recognition character	2	10.21
G,P,R,W	1F	SER.UOM, units of measure	6	10.22
R,W	20	SER.DLY, communication turnaround delay	2	10.23
G,P,R,W	21	SP 1, setpoint 1 value	6	10.24
G,P,R,W	22	SP 2, setpoint 2 value	6	10.24
G,P,R,W	23	SP 3, setpoint 3 value	6	10.24
G,P,R,W	24	SP 4, setpoint 4 value	6	10.24
G,P,R,W	25	INP.OF, input offset	6	10.5
G,P,R,W	26	OUT.OF, analog output offset	6	10.5
G,P,R,W	40	RAM or EEPROM BLOCK A	60	10.25.1
G,P,R,W	41	RAM or EEPROM BLOCK B	38	10.25.2
R,W	42	EEPROM BLOCK C	20	10.25.3
R,W	43	EEPROM BLOCK D	-	
R,W	44	EEPROM BLOCK E	-	
R,W	45	EEPROM BLOCK F	-	



Command
and
Response
Structure

NOTES:

- Each BLOCK is the string of HEX-ASCII data which is produced by the concatenation of the data for single items listed below:

BLOCK A =
26+17+25+0B+09+08+24+23+22+21

BLOCK B =
1E+1F+20+1A+18+13+12+11+10+05+0C+16+07+1C+1B+0E+0A

BLOCK C =
1D+15+14+04+03+02+01

NOTES: (cont)

BLOCKS D, E AND F are meter factory calibration values described in the separate "METER CALIBRATION MANUAL". (Adjustment of these values should be made with care, preferably using a well-equipped calibration laboratory.)

2. Suffixes 06, 0D, 0F, and 19 are not used: the meter will respond to these with an error message.
3. The meter, upon completion of a BLOCK PUT (into RAM) Command, goes to soft reset, "RESET1", which does not copy EEPROM data into RAM.
4. Upon completion of a BLOCK WRITE (into EEPROM) Command, however, the meter goes to hard reset, "RESET2", copying the data from EEPROM into the working RAM. Single PUT (or WRITE) commands do not interrupt the measurement process of the meter, even when the changes are to scale or offset values.
5. <data> encoding for Write and Put Commands will be described in Section 10 with each Read and Get response.

8

Command
and
Response
Structure

Table 8.3. Command Letters and Suffixes for Rate Meter/Totalizers

COMMAND	SUFFIX	ITEM AFFECTED	# CHAR	SECTION
D	01	Disable setpoints (SP1-SP5)	—	8.2.3
E	01	Enable setpoints (SP1-SP5)	—	8.2.3
G,P,R,W	01	Setpoint 1 value	6	11.16
U	01	Setpoints status	1	8.2.3
V	01	Read data string	Variable	8.2.3
X	01	Read batch (rate) value	7	8.2.3
Z	01	Reset A	—	8.2.3
D	02	Display hold	—	8.2.3
E	02	Display RUN	—	8.2.3
G,P,R,W	02	Setpoint 2 value	6	11.16
X	02	Read No. of batches (AVRTE)	7	8.2.3
Z	02	Reset B	—	8.2.3
D	03	Display brightness is 50% of normal	—	8.2.3
E	03	Display brightness is normal	—	8.2.3
G,P,R,W	03	Setpoint 3 value	6	11.16
U	03	Microprocessor Revision	1	8.2.3
X	03	Read TOTAL value	7	8.2.3
Z	03	Reset C	—	8.2.3
D	04	Stop (only in Batch mode)	—	8.2.3

(continued next page)

(continued from previous page)

COMMAND	SUFFIX	ITEM AFFECTED	# CHAR	SECTION
E	04	Set alarm mode	—	7.2.2
G,P,R,W	04	Setpoint 4 value	6	11.16
X	04	Read time value	8	8.2.3
Z	04	Reset LATCHED setpoints	—	8.2.3
E	05	Start (Batch mode only)	—	8.2.3
G,P,R,W	05	Setpoint 5 value	6	11.17
Z	05	Power On reset (Hard reset)	—	8.2.3
G,P,R,W	06	L1 CNF (Lockout byte 1)	2	11.1
G,P,R,W	07	L2 CNF (Lockout byte 2)	2	11.1
G,P,R,W	08	L3 CNF (Lockout byte 3)	2	11.1
R,W	09	MODE (operational mode)	2	11.2
G,P,R,W	0A	CONFG 1 (Configuration 1)	2	11.4
G,P,R,W	0B	CONFG 2 (Configuration 2)	2	11.5
G,P,R,W	0C	CONFG 3 (Configuration 3)	6	11.6
G,P,R,W	0D	CONFG 4 (Configuration 4)	2	11.7
G,P,R,W	0E	AV.CNF (Average configuration (only available for rate or square-root rate)	2	11.8
G,P,R,W	11	Bat DP (Batch decimal point) or RTE DP (Rate decimal point)	2	11.13
G,P,R,W	12	B.LOAD (Batch load) or RTE OF (Rate Offset)	6	11.14
G,P,R,W	13	BAT SC (Batch Scale) or RTE SC (Rate Scale)	6	11.14
G,P,R,W	14	TOT DP (Total decimal point)	2	11.13
G,P,R,W	15	TOT OF (Total Offset)	6	11.14
G,P,R,W	16	TOT SC (Total Scale)	6	11.14
G,P,R,W	17	AL TI (Alarm time)	4	11.11
G,P,R,W	18	GATE T (Gate time)	2	11.9
R,W	19	Baud rate	2	11.22
R,W	1A	SER.CNF (Serial Communication Configuration)	2	11.23
G,P,R,W	1B	DAT FT (Communication Bus Format)	2	11.24
G,P,R,W	1C	BUS FT (Communication Bus Format)	2	11.25
G,P,R,W	1D	ADDRES (RS-485 device # address)	2	11.26
G,P,R,W	1E	SER TI (time between each transmission)	4	11.27
R,W	1F	SET TI (Set Time)	6	11.18
G,P,R,W	20	Pulsed setpoint number	2	11.10
G,P,R,W	21	Scale operator	2	11.15
G,P,R,W	22	Input Scale	6	11.12

8

Command
and
Response
Structure

(continued next page)

(continued from previous page)

8

Command
and
Response
Structure

COMMAND	SUFFIX	ITEM AFFECTED	# CHAR	SECTION
G,P,R,W	23	Input Offset	6	11.12
G,P,R,W	24	Communication Recognition character	2	11.28
R,W	25	Communication Turnaround Delay	2	11.30
G,P,R,W	26	Output scale	6	11.19
G,P,R,W	27	Output offset	6	11.20
G,P,R,W	28	Time value	6	11.21
G,P,R,W	29	Total raw value	8	11.21
G,P,R,W	2A	Batch raw value (In Batch mode only)	8	11.21
G,P,R,W	2B	# of Batches raw value (In Batch mode only)	6	11.21
G,P,R,W	2C	Unit of measure #1	6	11.29
G,P,R,W	2D	Unit of measure #2	6	11.29
R,W	2E	Clock frequency calibration	2	11.31
R,W	2F	Analog out Volt zero calibration	4	11.31
R,W	30	Analog out Volt span calibration	4	11.31
R,W	31	Analog out current zero calibration	4	11.31
R,W	32	Analog out current span calibration	4	11.31
G,P	33	Display mode	2	11.3
G,P,R,W	40	RAM or EEPROM Block A	Batch: 76 Rate (SQ RT): 78	11.32
G,P	41	RAM Block B	Batch and (SQ RT): 34	11.32
R,W	41	EEPROM Block B	Rate: 36 Batch and (SQ RT): 50	11.32
G,P,R,W	42	RAM or EEPROM Block C (only for Batch mode)	Rate: 52	11.32
R,W	43	EEPROM Block D	22	11.32
R,W	44	EEPROM Block E	12 18	11.32

NOTES:

1. Each BLOCK is the string of HEX-ASCII data which is produced by the concatenation of the data for single items listed below:

a) For BATCH mode:

Block A (for G,P,R,W commands)=

16+15+14+13+12+11+0D+0C+0B+0A+08+07+06+05+04+03+02+01

Block B (for G and P commands)=

25+24+23+22+21+20+1E+1D+1C+1B+17

Block B (for R and W commands):

27+26+25+24+23+22+21+20+1E+1D+1C+1B+1A+19+17

Block C (for G,P,R,W commands):

2B+2A+29

Block D (for R and W commands):

2D+2C

Block E (for R and W commands):

32+31+30+2F+2E

b) For Rate mode and Square-root mode:

Block A (for G,P,R,W commands):

16+15+14+13+12+11+0E+0D+0C+0B+0A+08+07+06+05+04+03+02+01

Block B (for G and P commands):

For rate mode:

25+24+23+22+21+20+1E+1D+1C+1B+18+17

For Square-root mode:

27+26+25+24+23+22+21+20+1E+1D+1C+1B+1A+19+17

Block C:

Not available

Block D (for R and W commands):

2D+2C

Block E (R and W commands):

32+31+30+2F+2E



Command
and
Response
Structure

8

Command
and
Response
Structure

2. Suffixes 0E and 0F are not used: the meter will respond to these with an error message.
3. The meter, upon completion of a BLOCK PUT (into RAM) Command, goes to soft reset which does not copy EEPROM data into RAM.
4. Upon completion of a BLOCK WRITE (into EEPROM) Command, however, the meter goes to hard reset copying the data from EEPROM into the working RAM. Single PUT (or WRITE) commands do not interrupt the measurement process of the meter, even when the changes are to scale or offset values.
5. <data> encoding for Write and Put Commands will be described in Section 11 with each Read and Get response.

8.3 - RESPONSE STRUCTURE

The meter transmits different response formats according to the type of command it receives, e.g. if it is in echo or no-echo mode and if an error has occurred or not.

8.3.1 NO ERROR

8.3.2 ECHO MODE (SEE SECTIONS 10.19 AND 11.25)

For type (1) Command:
[nn]ccc<data>[hh]<CR><LF>

For type (2) Command:
a) Response for "V01" Command for the Process, Strain Gauge, Temperature, or Universal meters
[nn][V01][Sa][b][S<value>][S<value>][S<value>][S<value>][<SP>uuu][hh]<CR><LF>

b) Response for "V01" Command for the rate meter/totalizer or batch meters
[nn][V01][Sa][S<value>][SP<uuu>][S<value>][SP<uuu>][S<value>][SP<uuu>][S<value>][hh]<CR><LF>

c) Response for "X" Command
[nn]ccc<value>[hh]<CR><LF>

For type (3) Command:
[nn]ccc<d>[hh]<CR><LF>

For type (4) Command:

a) For "P" and "W" Command:

[nn][ccc][hh]<CR>[<LF>]

b) For "Y" Command (Process, Strain Gauge, Temperature and Universal meters only):

[nn]Y01<CR>[<LF>]

For type (5) Command:

[nn]ccc[hh]<CR> [<LF>]

8.3.3 NO ECHO MODE

For Commands "P", "W", "D", "E", "Z", and "Y"

No response will be transmitted

For Type (1) Commands:

<data>[hh]<CR>[<LF>]

For Type (2) Commands:

a) For "V01" Command:

1) For the Process, Strain Gauge, Temperature and Universal meters:

[Sa][b]S<value>|S<value>|S<value>|S<value>|S<value>|<SP>uuu[hh]<CR>[<LF>]

2) For the Rate meter/totalizer or Batch meters:

[Sa][S<value>|SP<uuu>|S<value>|SP<uuu>|S<value>|<SP>uuu|S<value>| [hh]<CR>[<LF>]

b) For "X" Command:

<value>[hh]<CR>[<LF>]

For Type (3) Commands:

<d>[hh]<CR>[<LF>]

Where "nn" is the meter's address in HEX format and is omitted from the response format if the communication is in the point-to-point mode. "ccc" is the three (3) character command prefix letter and it's suffix number. "d" is one ASCII character.

"[hh]" is the optional checksum "CR" is carriage return "[<LF>]" is optional line feed.

8

Command
and
Response
Structure

8

Command and Response Structure

"[Sa[b]]" is the optional alarm status character followed by the optional peak/valley status character. Alarm status character is preceded by the chosen plain-ASCII separator character, <S> or <CR>, depending on how you want this data displayed.

"S<value>" is the separator followed by the decimal-digit measurement value, with plain-ASCII minus sign (if any) and decimal point.

"[S<value>]" is the optional inclusion of the separator followed by any one of the three added decimal-digit values listed above.

"[<SP>uuu]" is the optional three units-of-measure characters (letters or other printable plain-ASCII symbols) preceded by a space; "<CR>" is the terminating plain-ASCII Carriage Return character.

[<LF>] optional line feed.

NOTE: A positive overflow in any one of the <value>s results in the transmission of "?+999999" for that value; negative overflow sends "?-999999".

8.4 DATA LENGTH CORRESPONDING TO THE RESPONSE STRUCTURE

For "R" and "G" Commands:

Data is equivalent to the "W" and "P" Commands respectively (see Table 8-2).

For "V01" and "X" Commands:

a) Value has 7 characters (like 724.352 or -233.45), unless overflow occurs in which case it consists of 8 characters (see note above)

b) Status characters "a" or "b" are each one character

For "U" Commands:

Data is one character.

8.5 ERROR RESPONSE

The meter is capable of detecting the different errors during the communication process and will transmit an indicating message to the host controller.

8.5.1 ERROR RESPONSE FORMAT

1. Echo Mode
[nn]?ee<CR>|<LF>

2. No echo mode
?ee<CR>|<LF>

where “?ee” is the special code indicating an error has occurred as follows:

8.5.2 ERROR MESSAGE

Table 8.4. Error Messages

	ERROR MESSAGE	CODE
1	Command Error	743
2	Format Error	746
3	Checksum Error	748
4	Parity Error	750
5	Calibration/Write Lockout Error	74C
6	EEPROM Write Lockout Error	745
7	Serial Device Address Error	756
8	Decimal Point Error	756
9	Serial Recognition Error	756
10	Invalid Character(s) used in <data> with Y01 Command	756

8

Command
and
Response
Structure

8.5.3 DESCRIPTION

1. COMMAND ERROR occurs when:
 - a. Command prefix letter is not valid
 - b. Command suffix is not valid

8

Command and Response Structure

2. **FORMAT ERROR** occurs when:
 - a. Length of the message is either shorter or longer than it should be.
 - b. Any other character than "0-F" used for hexadecimal values
3. **CALIBRATION LOCKOUT ERROR** occurs if jumper "S3B" (on the Main Board of the Process, Strain Gauge, Temperature or Universal meters) or S1A (on the Main Board of the rate meter/totalizer or batch meter) on the Main Board has been removed to prohibit any changes in calibration.
4. **EEPROM WRITE LOCKOUT ERROR** occurs if any write ("W") Command has been issued to the meter and the jumper position "S3A" on the Main Board of the meter has been removed

or

External pin 10 on the rear connector "P2" of the meter has been grounded.
5. **SERIAL RECOGNITION CHARACTER ERROR** occurs if a new value is between 0 to 1F (hex) or larger than 7F (hex). "^", "A", "E", are not valid since those are used in the special communication command "AAE".
6. **SERIAL DEVICE ADDRESS ERROR** occurs if the new value is larger than 199 decimal.
7. For Process, Strain Gauge, Temperature or Universal meters, **DECIMAL POINT ERRORS** occur if:
 - a. New value is 0 or larger than 6 (3 when the meter is in the Thermocouple or RTD modes)
 - b. New value causes the reading offset to overflow, i.e., larger than 999999 or less than -999999)
 - c. New value causes any of the setpoints to overflow, i.e., larger than 999999 or smaller than -999999)

8. For Rate meter/totalizer or Batch meters, DECIMAL POINT ERRORS occur if:
- a. New offset values cannot be accommodated on the display with the current decimal point position
 - b. New setpoint values cannot be accommodated on the display with the current decimal point position

IMPORTANT NOTES:

- 1) The meter will not respond to a command if the command's recognition character does not match the meter's recognition character.
- 2) When in multipoint mode, the meter will test the command's address with the one previously assigned after the recognition character has been matched. The meter will not respond to the command if addresses do not match, even if an error has occurred.
- 3) If the meter is in the Menu or Setpoint mode and receives any transmitted data, it quits that routine, displays "SERIAL" for up to two seconds, completes its Communication job, and then resets the meter, i.e., hard reset (RESET 2) from Menu, or soft reset (RESET 1) from Setpoint. (The Rate meter/totalizer or Batch meter resets respectively, but displays the mode before reverting to RUN.)
- 4) Any attempt to use push buttons when meter is in Transmit/Receive mode will be denied and followed by the display of "SERIAL", indicating that Communication is in process.

8

Command
and
Response
Structure

8.6 STATUS CHARACTER FORMATS

The meter upon receiving U01 or U02 Command will transmit alarm or peak/valley status characters respectively.

8.6.1 ALARM STATUS CHARACTERS

Table 8.5 shows the transmitted character for each of the sixteen possible setpoint/alarm states for Process, Strain Gauge, Temperature, or Universal meters. (Note the binary progression.)

Table 8.5. Temperature/Process/Strain/Universal Meter Alarm Status Characters

CHARACTER	SP#4	SP#3	SP#2	SP#1
@	OFF	OFF	OFF	OFF
A	OFF	OFF	OFF	ON
B	OFF	OFF	ON	OFF
C	OFF	OFF	ON	ON
D	OFF	ON	OFF	OFF
E	OFF	ON	OFF	ON
F	OFF	ON	ON	OFF
G	OFF	ON	ON	ON
H	ON	OFF	OFF	OFF
I	ON	OFF	OFF	ON
J	ON	OFF	ON	OFF
K	ON	OFF	ON	ON
L	ON	ON	OFF	OFF
M	ON	ON	OFF	ON
N	ON	ON	ON	OFF
O	ON	ON	ON	ON

Table 8.6 shows the transmitted character for each of the thirty-two possible setpoint/alarm states for rate meter/totalizers. (Note the binary progression.)

Table 8.6. Rate Meter/Totalizer/Batch Alarm Status Characters

CHARACTER	SP#5	SP#4	SP#3	SP#2	SP#1
@	OFF	OFF	OFF	OFF	OFF
A	OFF	OFF	OFF	OFF	ON
B	OFF	OFF	OFF	ON	OFF
C	OFF	OFF	OFF	ON	ON
D	OFF	OFF	ON	OFF	OFF
E	OFF	OFF	ON	OFF	ON
F	OFF	OFF	ON	ON	OFF
G	OFF	OFF	ON	ON	ON
H	OFF	ON	OFF	OFF	OFF
I	OFF	ON	OFF	OFF	ON
J	OFF	ON	OFF	ON	OFF
K	OFF	ON	OFF	ON	ON
L	OFF	ON	ON	OFF	OFF
M	OFF	ON	ON	OFF	ON
N	OFF	ON	ON	ON	OFF
O	OFF	ON	ON	ON	ON
P	ON	OFF	OFF	OFF	OFF
Q	ON	OFF	OFF	OFF	ON
R	ON	OFF	OFF	ON	OFF
S	ON	OFF	OFF	ON	ON
T	ON	OFF	ON	OFF	OFF
U	ON	OFF	ON	OFF	ON
V	ON	OFF	ON	ON	OFF
W	ON	OFF	ON	ON	ON
X	ON	ON	OFF	OFF	OFF
Y	ON	ON	OFF	OFF	ON
Z	ON	ON	OFF	ON	OFF
a	ON	ON	OFF	ON	ON
b	ON	ON	ON	OFF	OFF
c	ON	ON	ON	OFF	ON
d	ON	ON	ON	ON	OFF
e	ON	ON	ON	ON	ON

8

Command
and
Response
Structure

8

Command
and
Response
Structure

8.6.2 PEAK/VALLEY (HI/LO) STATUS CHARACTERS

(Process, Strain Gauge, Temperature or Universal meters only)

Table 8.7 gives the characters transmitted to show changes in Peak/Valley readings.

The meter keeps track of Peak and Valley changes at the completion of each measurement, so that the occurrence of new values can be signaled. However, transmissions of PEAK/VALLEY status may be commanded less often: therefore, the meter also monitors if Peak or Valley values have changed since the last status transmission.

Table 8.7. Peak/Valley Status Characters for Process/Temperature/Universal/Strain Meters

CHARACTER	PEAK LARGER THAN LATEST TRANSMISSION	VALLEY LESS THAN LATEST TRANSMISSION	PEAK LARGER THAN LATEST READING	VALLEY LESS THAN LATEST READING
@	NO	NO	NO	NO
D	NO	YES	NO	NO
E	NO	YES	NO	YES
H	YES	NO	NO	NO
J	YES	NO	YES	NO
L	YES	YES	NO	NO
M	YES	YES	NO	YES
N	YES	YES	YES	NO

8.7 "V01" OR "EXTERNAL PRINT" RESPONSE DATA FORMAT

As described in Section 8.3 response to the "V01" Command has the following format if in echo mode:

For the Process, Strain Gauge, Temperature or Universal meters:

```
[nn][V01][Sa][b]]S<value>[S<value>][S<value>][S<value>][<SP>uuu][hh]<CR>[<LF>]
```

For the rate meter/totalizer or batch meter:

```
[nn][V01S][Sa][S<value>][SP<uu>][S<value>][SP<uu>][S<value>][SP<uu>][S<value>][hh]<CR>[<LF>]
```

"nnV01" is omitted from the response format if in no-echo mode; where:

Table 8.8. Description of Special Characters Used for Communication Commands.

CHARACTERS	PROCESS, STRAIN GAUGE, TEMP., UNIVERSAL METER	RATE/SQ METER	BATCH METER
a	Alarm status character	Same	Same
b	Peak/valley status character	N/A	N/A
first<value>	Value of current reading	Rate value	Batch value
second<value>	Value of filtered reading	Average	No. of batches
third<value>	Value of peak reading	Rate value	Total value
fourth<value>	Value of valley reading	Total value	Total value
<SP>	Space	Time value	Time value
S	Space or <CR>	Same	Same
<uuu> ¹	Three characters for the unit of measurement	Same	Same
<uuu> ²	N/A	First unit of measurement	First unit of measurement
hh	Checksum	Second unit of measurement	Second unit of measurement
<CR>	Carriage return	Same	Same
LF	Line feed	Same	Same
[]	Optional item	Same	Same

8

Command and Response Structure

The length of the message transmitted by the meter in response to the "V01" command is variable and controlled by the two menu items as "DAT FT" (Data Format) and "BUS FT" (Bus Format). (See Sections 10.18 and 10.19 for strain, temperature, process and universal; and Sections 11.24 and 11.25 for ratemeter/totalizer, batch), (For pushbutton programming, see Appendix A).

8.8 "**^AE**" RESPONSE FORMAT

The meter's response to "**^AE**[nn]<CR>" is 4 bytes of data, sent as 8 HEX-ASCII characters, followed by a carriage return (no other characters even when programmed to echo). These four bytes are:

- 1: Serial Recognition Character below; e.g., "*", sent HEX-ASCII "2A")
- 2: Device Address (this is sent even when the meter is set for point-to-point; below; e.g., "199", sent as HEX-ASCII "C7")
- 3: Bus Format Byte ("BUS FT"; e.g., HEX-ASCII "5C" for multipoint mode with echo)
- 4: Serial Communications Configuration Byte ("SER.CNF"; e.g., HEX-ASCII "56" for 2 stop bits, even parity, and 19200 baud)

8.9 EXAMPLES: TEMPERATURE/PROCESS/STRAIN/ UNIVERSAL METERS

The following are examples of the different commands and their proper responses from temperature/process/strain/universal meters. For the following examples assume that:

- a) echo mode
- b) "*" as the recognition character of the meter
- c) meter's address is "15 HEX" if it is used in the multipoint mode
- d) no line feed or checksum characters are included

8

Command
and
Response
Structure

1. Read serial recognition character from EEPROM in point-to-point mode:

Command format *R1E<CR>
Response format R1E2A<CR>
(Since "2A" is HEX-ASCII value of "*" in the table).

2. Read serial address from the RAM of the meter number "15 HEX" in the multipoint mode:

Command format *15G1A<CR>
Response format 15G1A15<CR>

3. Write "VLT" as units of measure into the EEPROM of the meter in the point-to-point mode:

Command format *W1F564C54<CR>
Response format W1F<CR>

where 56, 4C, 54 are the three HEX ASCII values for V, L, and T respectively.

4. Read alarm status character from the meter number 15 HEX:

Command format *15U01<CR>
Response format 15U01@<CR>

where "@" is the alarm status character, decoded using Table 8.5 or 8.6.

5. Enable serpoints number 3 and 4 in point-to-point mode:

Command format *E01<CR>
Response format E01<CR>

6. Hold display value on meter number 15 HEX:

Command format *15D04<CR>
Response format 15D04<CR>

7. Cold reset (reset 1) in point-to-point mode:

Command format *Z04<CR>
Response format Z04<CR>

8. Publish measurement string from the meter in point-to-point mode:

Command format *V01<CR>
Response format V01 567.891 567.880 712.345 110.765<CR>

9. Publish current reading value from the meter number 15 HEX in multipoint mode:

Command format *15X01<CR>
Response format X01 567.891<CR>

10. Read block of data from EEPROM in point-to-point mode:

Command format *R42<CR>
Response format R42271100010001E03E003F<CR>

11. Display "HELLO" onto the meter number 15 HEX in multipoint mode:

Command format *15Y01HELLO<CR>
Response format 15Y01<CR>

8

Command
and
Response
Structure

8

Command and Response Structure

8.10 EXAMPLES: RATE METER/TOTALIZERS/BATCH

The following are examples of the different commands and their proper responses from rate meter/totalizers, batch. For the following examples assume that:

- a) echo mode
- b) "*" as the recognition character of the meter
- c) meter's address is "15 HEX" if it is used in the multipoint mode
- d) no line feed or checksum characters are included

1. Read serial recognition character from EEPROM in point-to-point mode:

Command format *R24<CR>
Response format R242A<CR>
(Since "2A" is HEX ASCII value of "*" in the table).

2. Read serial address from the RAM of the meter number "15 HEX" in the multipoint mode:

Command format *15G1D<CR>
Response format 15G1D15<CR>

3. Write "GPM" as units of measure into the EEPROM of the meter in the point-to-point mode:

Command format *W2C47504D<CR>
Response format W2C<CR>

where 47, 50, 4D are the three HEX-ASCII values for G, P, and M respectively.

4. Read alarm status character from the meter number 15 HEX:

Command format *15U01<CR>
Response format 15U01@<CR>

where "@" is the alarm status character, decoded using Table 8.3.

5. Enable all setpoints in point-to-point mode:

Command format *E01<CR>
Response format E01<CR>

6. Hold display value on meter number 15 HEX:

Command format *15D02<CR>
Response format 15D02<CR>

7. Cold reset (reset 1) in point-to-point mode:

Command format *Z05<CR>
Response format Z05<CR>

8. Transmit measurement string from the meter in point-to-point mode when the meter is operating in Rate Mode and DAT FT bits DAT.2 through DAT.4 are enabled:

Command format *V01<CR>
Response format V01 567.891 567.880 712.345 110.765<CR>

where 567.891 is the RATE value, 567.880 is the AVG RT value, and 712.345 is the TOTAL value.

9. Transmit current BAT NO value from the meter number 15 HEX in multipoint mode when the meter is operating in Batch Mode:

Command format *15X02<CR>
Response format X0256<CR>
therefore BAT NO is 56 decimal

10. Read block of data from EEPROM in point-to-point mode when the meter is operating in Batch Mode:

Command format *R42<CR>
Response format R4244114<CR>

where 44 HEX is the TOTAL value, 11 HEX is the Batch count, and 4 HEX is the BAT NO.

8

Command
and
Response
Structure

Notes:

8

Command and Response Structure

9. Meter Bus Response

As detailed before, the meter can receive and transmit at baud rates up to 19,200. No data is ever lost by the meter even at the highest rate with the most complex meter program, provided that the computer does not attempt to interrupt a transmission from the meter by transmitting at the same time.

When not transmitting, the meter continually looks for a new character on the bus. When any character is received, the meter drops out of ALARM mode; (if in that mode) checks for the Recognition Character, the start of a new message.

Remember that the menu item "BUS FT" sets different modes of communications as:

1. BUS .3 = 0: No echo mode
= 1: echo mode
2. BUS .4 = 0: Point-to-Point
= 1: Multipoint
3. BUS .5 = 0: Point-to-Point continuous mode
= 1: Point-to-Point command mode
4. BUS .6 = 0: Message handshake when continuous mode
= 1: Character handshake when continuous mode

9

Meter
Bus
Response

9.1 POINT-TO-POINT OR MULTIPOINT COMMAND MODE

If the recognition character is correct, the meter now checks for the address in the Multipoint mode.

When a match is obtained, the meter then decodes the Command Code and fulfills that command. Otherwise, the meter ignores the command and continues to look for another recognition character.

9.1.1 METER'S RESPONSE TIME

RESPONSE TIME: this is the period from the time the meter detects the first command character to the time that it starts transmitting proper response.

9

Meter Bus Response

Response time = Transmit command time + program delay time + turn around delay time.

Where:

Transmit Command Time = the transmission period of full command from the host computer to the meter.

$[(\# \text{ of bits in a character}) * (\# \text{ of characters})] \div [\text{baud rate}]$ (in seconds) where: * = Multiply.

of bits in a character = 10 or 11 (see Sections 4.12 and 6);

Turn around delay = Receive to transmit delay and can be programmable to 0, 30, 100, 300 ms (200 ms for ratemeter totalizer). For the following data turn around delay assumed 0.

METER RESPONSE TIME:

1) For Process, Strain Gauge, Temperature and Universal meters:

- a) Slow mode = 0 to 300 ms
- b) fast mode = 0 to 100 ms

2) For Ratemeter/totalizer, Batch meter with chunk transmission:

- a) Rate mode = 0 to 35 ms
- b) Batch mode = 0 to 20 ms
- c) Square-root mode= 0 to 40 ms

3) For Ratemeter/totalizer, Batch meter with single long transmission:

- a) Rate mode = 0 to 80 ms
- b) Batch mode = 0 to 50 ms
- c) Square-root mode= 0 to 85 ms

NOTE: Although single long transmission's delay seems longer than chunk transmission, in most cases total transmission time will be shorter, especially using 19200 baud rate.

9.2 POINT-TO-POINT CONTINUOUS MODE

As described before, the meter transmits its different measurement values in strings of characters continuously on the bus. The length of the string is variable and is controlled by two menu items: "DAT FT" and "BUS FT" (see Sections 10.18 and 10.19). The time between consecutive transmission is also controlled by another menu item: "SERCNT" (for temperature, process, strain, universal meters) or "SER TI" (for rate/totalizer, batch meters). This item is in units of "numbers of readings" for temperature, process, strain, universal (Section 10.20) and "Time in seconds" for ratemeter/totalizer, batch (Section 11.27).

9.2.1 METER'S RESPONSE TIME

For Process, Strain Gauge, Temperature and Universal meters, this is the difference in time from the moment when the Serial Count ("SERCNT") value is reached to the time of transmission of the first character of the data string. For rate/totalizer, batch meters, this is the difference in time from the moment when the Serial Time ("SER TI") value is reached to the time of transmission of the first character of the data string.

METER RESPONSE TIME:

1) For Process, Strain Gauge, Temperature and Universal meters:

- a) Slow mode = 0 to 300 ms
- b) fast mode = 0 to 100 ms

2) For Ratemeter/totalizer, Batch meter with chunk transmission:

- a) Rate mode = 0 to 35 ms
- b) Batch mode = 0 to 20 ms
- c) Square-root mode = 0 to 40 ms

3) For Ratemeter/totalizer, Batch meter with one time transmission:

- a) Rate mode = 0 to 80 ms
- b) Batch mode = 0 to 50 ms
- c) Square-root mode = 0 to 85 ms

9

Meter
Bus
Response

NOTE: Although transmission's program delay seems longer than chunk transmission, in most cases total transmission time will be shorter, especially using 19200 baud rate.

9.2.2 COMMUNICATING WITH THE METER WHEN IN CONTINUOUS MODE

If the meter is in point-to-point continuous mode, it ignores any transmitting command. On the other hand, transmitting "X-OFF" character (13 Hex) which is equivalent to the "RTS line false" will halt continuous transmission. Transmitting "X-ON" character (11 hex) or making "RTS line true" will resume continuous transmission. Specifically, if command "^AE" is transmitted, it will cause the meter to switch to COMMAND mode.

To be able to communicate with the meter when in Continuous Mode, do the following:

1. Transmit "X-OFF" character or make "RTS" line false.
2. Transmit "^AE" command. Now your meter is in Command Mode.
3. Do the communication with the meter.
4. Use "PIC" command to change BUS FORMAT (see Section 10.19 for Process, Strain Gauge, Temperature and Universal meters and Section 11.25 for Rate meter/totalizer and batch meters) i.e., change bit #4 of "BUS FT" from 1 to 0 to go back to Continuous Mode.

9

Meter
Bus
Response

9.3 MULTIPOINT ALARM MODE RESPONSE

The meter is commanded into the ALARM mode by detecting the alarm code—E03 for temperature, process, strain, universal meters, or E04 for rate/totalizer, batch meters—after its own address or the common 00 address. It stays silent unless an alarm already exists. If an alarm is detected, it immediately transmits its own address with its alarm status characters. No turnaround time delay is used. All devices on the bus which are in the ALARM mode drop out of that mode if any character is detected on the bus, so that bus contention is minimized.

The program for the controlling device (computer) is usually written to poll the alarm status of all devices once bus activity is detected after an alarm command, so that nearly-simultaneous alarm conditions are properly detected.

Such a meter poll by the computer after an alarm response usually starts at the detected device address, or at device 01 in case of a garbled address (if two or more devices alarm at once).

If there is adequate time allowance in the data acquisition program, the computer may poll the alarm status of all meters before commanding the ALARM mode to reduce the probability of bus contention and garbled transmissions.

9.3.1 METER'S RESPONSE TIME

1) For Process, Strain Gauge, Temperature and Universal meters:

- a) Slow mode = 0 to 300 ms
- b) fast mode = 0 to 100 ms

2) For Raremeter/totalizer, Batch meter with chunk transmission:

- a) Rate mode = 0 to 35 ms
- b) Batch mode = 0 to 20 ms
- c) Square-root mode= 0 to 40 ms

3) For Ratemeter/totalizer, Batch meter with one time transmission:

- a) Rate mode = 0 to 80 ms
- b) Batch mode = 0 to 50 ms
- c) Square-root mode= 0 to 85 ms

NOTE: Although transmission's program delay seems longer than chunk transmission, in most cases total transmission time will be shorter, especially using 19200 baud rate.

9

Meter
Bus
Response

9.4 EXTERNAL PRINT COMMAND

This command is valid in point-to-point and multipoint command mode only.

To use this command for the Process, Strain Gauge, Temperature or Universal meters, bit "BUS.8" must "1" (Refer to Section 10.23).

To use this command for the Rate meter/totalizer or Batch meters, bit "CF4.4" must equal "1" (Refer to Section 11.7).

NOTE: Special attention and care should be taken when this feature is used with the multipoint mode and there is more than one meter on the bus. You must allow enough delay between consecutive external print commands (based on response times) to prevent collisions on the bus.

9.4.1 METER'S RESPONSE TIME

The time interval between the time when external print line becomes true to the time when the meter starts sending the first character of the data string.

METER RESPONSE TIME:

1) For Process, Strain Gauge, Temperature and Universal meters:

- a) Slow mode = 0 to 300 ms
- b) fast mode = 0 to 100 ms

2) For Ratemeter/totalizer, Batch meter with chunk transmission:

- a) Rate mode = 0 to 35 ms
- b) Batch mode = 0 to 20 ms
- c) Square-root mode= 0 to 40 ms

3) For Ratemeter/totalizer, Batch meter with one time transmission:

- a) Rate mode = 0 to 80 ms
- b) Batch mode = 0 to 50 ms
- c) Square-root mode= 0 to 85 ms

NOTE: Although transmission's program delay seems longer than chunk transmission, in most cases total transmission time will be shorter, especially using 19200 baud rate.

9.5 WATCHDOG TIMER FOR COMMUNICATION

There is an eight second watchdog timer available in the communication portion of the meter. When the computer starts sending a command to the meter, meter enables its receive mode and starts getting the incoming characters, until a carriage return completes the command string. Then the meter disables its receive mode and enables its transmission mode to transmit or act according to the command information. Receive mode time is the period that the meter is in receive mode. Receive time should always be less than eight seconds, otherwise meter will ignore the command and will finish the receive mode (there will be no affect on the performance of the meter). In this case command should be executed again. .

NOTE: Watchdog timer is disabled when meter is in continuous communication mode.

9

Meter
Bus
Response

Notes:

9

**Meter
Bus
Response**

10. Data Formats Associated with Commands (“P”, “G”, “R”, “W”) Process, Strain Gauge, Temperature or Universal Meters

This section introduces data formats in detail. The following conditions are assumed in the text and in examples in this section

1. The recognition character is the asterisk(*).
2. The meter address number is 15 HEX (21 decimal)
3. When “W” command is given, a reset is necessary to initiate the command.
4. “X” in bit pattern information means the bit is not related to that parameter.
5. Each byte consists of 8 bits.
6. Each byte consists of 2 nibbles; Most Significant Nibble (MSN) and Least Significant Nibble (LSN)

10.1 LOCKOUT BYTES

“R” or “W” followed by “01”, “02”, “03”, or “04” send to EEPROM or receive from EEPROM the 8 bits of each of the four lockout bytes.

For example, if you want to make L2 CNF be “01011010”, the hex equivalent is “5A”, so the computer sends “*15W025A<CR>”.

The meter would echo the command with “15W02<CR>” if “BUS.3=1”.

Below is the bit pattern corresponding to the lockout bytes.

NOTE: Each Lockout is one byte (8 bits) where:

- LIC.1 is bit 0 of Lockout #1
- LIC.8 is bit 7 of Lockout #1

Each item on the left will lock out following item on the right.

10

Data Formats for Process, Strain Gauge, Temperature, and Universal Meters

Table 10.1. Lockout Bytes

LOCKOUT	FUNCTION	CORRESPONDING ITEM
L1 CNF:		LOCKOUT CONFIGURATION #1
L1C.1 = 0	Unlocked	SP1: Setpoint 1
= 1	Locked	
L1C.2 = 0	Unlocked	SP2: Setpoint 2
= 1	Locked	
L1C.3 = 0	Unlocked	SP3: Setpoint 3
= 1	Locked	(AL1: Alarm 1)
L1C.4 = 0	Unlocked	SP4: Setpoint 4
= 1	Locked	(AL2: Alarm 2)
L1C.5 = 0	Unlocked	LO RDG: Valley Reading
= 1	Locked	
L1C.6 = 0	Unlocked	HI RDG: Peak Reading
= 1	Locked	
L1C.7 = 0	Unlocked	INPUT: Type of Input
= 1	Locked	
L1C.8 = 0	Unlocked	INPUT: Input Type Selection
= 1	Locked	
L2 CNF:		LOCKOUT CONFIGURATION #2
L2C.1 = 0	Unlocked	RDG.CNF: Reading Configuration
= 1	Locked	
L2C.2 = 0	Unlocked	RDG SC (RD.SC.OF): Reading Scale (or Reading Scale & Offset if 2-coordinate format chosen)
= 1	Locked	RDG OF: Reading Offset
L2C.3 = 0	Unlocked	IN CNF: Input Configuration
= 1	Locked	
L2C.4 = 0	Unlocked	IN.SC.OF: Input Scale & Offset (2-coordinate format)
= 1	Locked	DEC PT: Decimal Point Position
L2C.5 = 0	Unlocked	
= 1	Locked	
L2C.6 = 0	Unlocked	CNT BY: Count By
= 1	Locked	
L2C.7 = 0	Unlocked	FIL.CNF: Filter Configuration
= 1	Locked	

(continued next page)

10

Data Formats
for Process,
Strain Gauge,
Temperature,
and Universal
Meters

(continued from previous page)

LOCKOUT	FUNCTION	CORRESPONDING ITEM
L3 CNF:		LOCKOUT CONFIGURATION #3
L3C.1	= 0 Unlocked = 1 Locked	FIL TI: Filter Time Constant
L3C.2	= 0 Unlocked = 1 Locked	SP CNF: Setpoints 1 and 2 Configuration
L3C.3	= 0 Unlocked = 1 Locked	AL CNF: Alarms 1 & 2 (Setpoint 3 & 4 Configuration)
L3C.4	= 0 Unlocked = 1 Locked	AL FNC: Alarms 1 & 2 functions
L3C.5	= 0 Unlocked = 1 Locked	AL RDG: Number of readings for alarms 1 & 2 to be activated
L3C.6	= 0 Unlocked = 1 Locked	SP DB and AL DB: Setpoints 1 & 2 and Alarms 1 & 2 deadbands
L3C.7	= 0 Unlocked = 1 Locked	OUT.CNF: Output Configuration
L3C.8	= 0 Unlocked = 1 Locked	OT.SC.OF: Output scale and offset (2-coordinate format)
L4 CNF:		LOCKOUT CONFIGURATION #4
L4C.1	= 0 Unlocked = 1 Locked	BAUD: Baud Rate Communication
L4C.2	= 0 Unlocked = 1 Locked	SERCNF: Serial Communication Configuration
L4C.3	= 0 Unlocked = 1 Locked	ADDRES: Device address for RS-485
L4C.4	= 0 Unlocked = 1 Locked	DAT FT and BUS FT: Data Format and Bus Format
L4C.5	= 0 Unlocked = 1 Locked	SERCNT: (Number of readings between each printout)
L4C.6	= 0 Unlocked = 1 Locked	CAL VZ, CAL VS, CALmAZ, CALmAS, C.JUN.OF

10

Data Formats for Process, Strain Gauge, Temperature, and Universal Meters

10.2 INPUT TYPE ("INPUT")

All four commands with the Command Suffix "05" use just two characters (two nibbles of data). The most-significant nibble (MSN) gives the CLASS of input and the least-significant nibble (LSN) gives the selected range or TYPE.

Table 10.2. Input Type

BIT NUMBER				INPUT CLASS
7	6	5	4	
0	0	0	0	TC: Thermocouple
0	0	0	1	RTD: Resistance Temperature Detector
0	0	1	0	VOLT: DC Voltage
0	0	1	1	CURRNT: DC Current
-	-	-	-	Not Used
0	1	0	1	BRIDGE: Strain Gauge
0	1	1	0	POT: Potentiometer/Slide wire
-	-	-	-	Not Used

Table 10.3. Input Range for Thermocouple

BIT NUMBER				RANGE OR TYPE
3	2	1	0	
0	0	0	0	J
0	0	0	1	K
1	0	1	0	T
0	0	1	1	E
0	1	0	0	N
0	1	0	1	DIN J
0	1	1	0	R
0	1	1	1	S
1	0	0	0	B

Table 10.4 Input Range for RTD

BIT NUMBER				RANGE OR TYPE
3	2	1	0	
0	0	0	0	2-wire, 0.003926 Alpha (NIST)
0	0	0	1	3-wire, 0.003926 Alpha (NIST)
0	0	1	0	4-wire, 0.003926 Alpha (NIST)
0	0	1	1	2-wire, 0.00385 Alpha (DIN)
0	1	0	0	3-wire, 0.00385 Alpha (DIN)
0	1	0	1	4-wire, 0.00385 Alpha (DIN)
0	1	1	0	Linear or Ohms

10

Data Formats
for Process,
Strain Gauge,
Temperature,
and Universal
Meters

Table 10.5. Input Range or Type for VOLT

BIT NUMBER				INPUT RANGE	CONDITION If INP.3=
3	2	1	0		
0	0	0	0	-10 to 110 mV	0
0	0	0	0	-60 to 60 mV	1
0	0	0	1	-0.1 to 11 V	0
0	0	0	1	-0.60 to 0.60 V	1
0	0	1	0	-1 to 11 V	0
0	0	1	0	-6 to 6.0 V	1
0	0	1	1	-10 to 110 V	0
0	0	1	1	-60 to 60 V	1

Input Range or Type for Current

BIT NUMBER				INPUT RANGE
3	2	1	0	
0	0	0	0	0 to 20 mA
0	0	0	1	4 to 20 mA

NOTE: No Range or Type for Bridge or Pot.

EXAMPLE: The meter (#15 HEX, Recognition Character *) is to be placed on the 0-100V range. The computer writes to the EEPROM using MSN = 2 and LSN = 3 from the above table: *15W0523<CR>.

The meter will echo the command if BUS.3=1.

NOTE: If P05 is exercised, then meter will SOFT RESET (RESET 1) after completing communication.

10

Data Formats
for Process,
Strain Gauge,
Temperature,
and Universal
Meters

10.3 READING CONFIGURATION ("RDG.CNF")

2 characters (2 nibbles) of data are used for all four 07 commands:

Table 10.6. Reading Configuration ("RDG.CNF"), Bits 3, 2, 1, and 0.

BIT NUMBER				FUNCTION
3	2	1	0	
x	x	x	0	Direct entry, RDG SC, RDG OF
x	x	x	1	2-Data Point, RD.SC.OF
x	x	0	x	Active decimal point, digits move too
x	x	1	x	Independent decimal point location (not valid in TC or RTD)
x	0	x	x	Full display brightness
x	1	x	x	50% reduced brightness
0	x	x	x	Display leading zeroes
1	x	x	x	Don't display leading zeroes

Table 10.7. Reading Configuration ("RDG.CNF"), Bits 4, 5 and 6.

BIT NUMBER			FUNCTION (ONLY IN RTD OR TC MODES)
6	5	4	
x	0	0	Unit of measure on display "C"
x	0	1	Unit of measure on display "F"
x	1	0	Unit of measure on display "K"
x	1	1	Not used
0	x	x	Unit of measure not displayed
1	x	x	Unit of measure displayed

Table 10-8. Reading Configuration ("RDG.CNF"), Bit 7.

BIT NUMBER		FUNCTION
7		
0		Hard reset if pin P2-5 is activated
1		Peak & Valley reset if pin P2-5 is activated

EXAMPLE: The computer tells meter #15H, with Recognition Character "*" and echo requested with "BUS.3=1", to show units-of-measure as an "F" (at the right hand side of the display), to accept direct entry of the display (reading) scale and offset, to position data digits and decimal point together (active), to use full display brightness, and to suppress leading zeroes. The MSN is "5"

10

Data Formats
for Process,
Strain Gauge,
Temperature,
and Universal
Meters

from Table 10.7, and the LSN binary is "1,0,0,0" from Table 10.6, or HEX "8", so the computer sends: *15P0758<CR>, and the meter replies: 15P07<CR>.

These program choices are written to RAM with this **PUT** command, and will be written over by the program stored in EEPROM if and when there is a hard RESET ("RESET2"). For permanence, use "W07" to place this program in the EEPROM.

10.4 READING, INPUT, OR OUTPUT SCALE FACTOR ("RD SC", "IN SC", "OUT SC")

These items are 3 bytes each (6 HEX- ASCII characters) and their corresponding command suffixes are:

ITEM	COMMAND SUFFIX (HEX)
RD SC	08
IN SC	0B
OUT SC	17

All three scale factors can be calculated by the meter from entry of two data points (via pushbutton or diskette); only Reading Scale permits direct entry (to facilitate 1.00000 and other straight-forward values). Scale factor and Offset values, however, are stored separately inside the meter. If your scale/offset information is in the form of two data points (O2,I2 and O1,I1, where the O's are the Outputs for the I's, Inputs), then

$$SC = (O2-O1)/(I2-I1)$$

This value is entered/read with these "08", "0B" and "17" command suffixes, and also used in calculating the corresponding Offsets (see Section 10.9).

NOTE: True value for output scale factor is stored in its location in EEPROM. When the program is running, it combines this value with calibration scale of analog out board and stores new value in output scale's RAM location (CALLED MODIFIED OUTPUT SCALE). Therefore, "P17" for this scale factor should be used very carefully (avoid using if possible). But with "G17", the value of modified output scale factor can be read.

10

Data Formats
for Process,
Strain Gauge,
Temperature,
and Universal
Meters

10

Data Formats
for Process,
Strain Gauge,
Temperature,
and Universal
Meters

The most significant nibble of the scale factor data sets the decimal point (power of 10 multiplier) for the least-significant nineteen bits, which give the magnitude using a right-hand decimal point (decimal 499,999 full scale). The bit in between, #19, is the sign bit, "0" for "+" and "1" for "-", which is OR'd with the magnitude to get the HEX value of the second nibble. The decimal-point code is given in Table 10.9. The figure "4" indicates the maximum value in that position and "x" is any chosen decimal digit.

Bit pattern information is as follows:

- 1) Bits 0 to 18 belong to the absolute value.
- 2) Bits 20, 21, 22, 23, belong to decimal point as shown in Table 10.9.
- 3) Bit number 19 belongs to the sign and is "0" for positive and "1" for negative.

Table 10.9. Reading Scale ("RD SC"), Input Scale ("IN SC"), and Output Scale ("OUT SC") Bits 23, 22, 21 and 20

BIT NUMBER				DECIMAL NUMBER	POWER OF 10 MULTIPLIER
23	22	21	20		
0	0	0	0	4xxxxx0.	1
0	0	0	1	4xxxxx.0	0
1	0	1	0	4xxxx.x0	-1
0	0	1	1	4xxx.xx0	-2
0	1	0	0	4xx.xxx0	-3
0	1	0	1	4x.xxxx0	-4
0	1	1	0	4.xxxxx0	-5
0	1	1	1	.4xxxxx0	-6
1	0	0	0	.04xxxxx0	-7
1	0	0	1	.004xxxxx0	-8
1	0	1	0	.0004xxxxx0	-9
1	0	1	1	.00004xxxxx0	-10
1	1	0	0	.000004xxxxx0	-11
1	1	0	1	.0000004xxxxx0	-12
1	1	1	0	.00000004xxxxx0	-13
1	1	1	1	.000000004xxxxx0	-14

EXAMPLE: Desired reading scale factor is 123.45. The magnitude is 12345, which is hex 03039. The polarity is negative, so the 19th bit is a "1", giving hex "80000"; when OR'2 with the magnitude, the least-significant 5 nibbles are hex "83039".

The decimal-point is two places to the left of the right-hand position (e.g., of the 6-digit display). The decimal point is thus -2, which is a MSB of 3 from the Table 10-9.

OR'd with the other 5 nibbles, hex "383039", write this factor to the EEPROM of meter hex #15 with: *15W08383039<CR>. The meter will echo 15W08<CR> if you have set "BUS.3=1".

10.5 READING OFFSET ("RDG OF"), INPUT OFFSET ("INP OF"), OR OUTPUT OFFSET ("OUT OF")

These 3 ("09", "25" and "26" command suffixes) all use the same 3-byte (6-nibble or 6 character) format. The most significant bit is the sign bit, "=0" for a positive value, "=1" for a negative value. The other 3 bits of the MSN are used for decimal point (referenced to the right-hand display dp position) as given in the Table 10.10. The remaining 5 nibbles (20 bits) are the magnitude (resolution one ppm).

Your data might be in the form of two data points (O2,I2 and O1,I1); since the meter stores this information as separate scale and offset values, it is necessary to calculate the offset:

$$OF = O1 - SC * I1,$$

where the scale factor SC is that calculated by the equation in Section 10.4.

In Table 10.10, "9" represents the maximum leading digit, and "x" is any desired decimal.

Bit pattern information is as follows:

- 1) Bits 0 to 19 belong to the absolute value (99999 when value is negative and 999999 when value is positive).
- 2) Bits 20, 21, 22, belong to decimal point as shown in Table 10.10.
- 3) Bit number 20 is assigned to sign and is equal to "0" for positive and "1" for negative values.

Table 10.10. Reading Offset ("RD OF"), Input Offset ("IN OF"), and Output Offset ("OUT OF"), Bits 22, 21 and 20

BIT NUMBER			DECIMAL NUMBER	POWER OF 10 MULTIPLIER
22	21	20		
0	0	0	9xxxxx00.	2
0	0	1	9xxxxx0.	1
0	1	0	9xxxxx.0	0
0	1	1	9xxxx.x0	-1
1	0	0	9xxx.xx0	-2
1	0	1	9xx.xxx0	-3
1	1	0	9x.xxxx0	-4
1	1	1	9.xxxxx0	-5

10

Data Formats for Process, Strain Gauge, Temperature, and Universal Meters

10

Data Formats
for Process,
Strain Gaug,
Temperature,
and Universal
Meters

EXAMPLE: The computer requests the current display (reading) offset value from the meter hex #15 with: *15G09<CR>.

The meter (set to echo with "BUS.3=1") responds: 15G09D17618<CR>. To translate this, the 6 data nibbles are stripped out: "D17618". The most significant bit (of the "D" nibble) is a "1", so the offset is negative. Decimal point is at position 4.

The magnitude, HEX "17618", is decimal 95768, so the meter's decimal reading offset is -95.768.

NOTE: True value for Output Offset is stored in its location in EEPROM. When program is running, it combines this value with calibration offset of the Analog Output Board and stores new value (called **Modified Output Offset**) in Output Offset's RAM location. Therefore, "P26" for this offset should be used very carefully (avoid using if possible). But, with "G26", value of modified output offset can be read.

10.6 INPUT CONFIGURATION ("IN CNF")

This "0A" command suffix uses one byte (2 nibbles or 2 HEX-ASCII characters) to convey these item selections.

Table 10.11. Input Configuration ("IN CNF"), Bits 2, 1, and 0

BIT NUMBER			FUNCTION
2	1	0	
x	x	0	Line Frequency = 60 Hz
x	x	1	Line Frequency = 50 Hz
x	0	x	Slow (3/sec) reading rate
x	1	x	Fast (12/sec) reading rate
0	x	x	Unipolar (-10% to 110%) range input
1	x	x	Bipolar (-60% to 60%) range input

Table 10.12. Input Configuration ("IN CNF"), Bits 4, and 3

BIT NUMBER		FUNCTION (VALID IN RTD OR TC MODES)
4	3	
0	0	No transmitter
0	1	TC Transmitter
1	0	RTD transmitter
1	1	Not used

Table 10.13. Input Configuration ("IN CNF"), Bits 7, 6, and 5

BIT NUMBER			FUNCTION
7	6	5	
x	x	0	Using the meter cold Junction if TC mode or 3-wire linear RTD
x	x	1	Using Remote cold junction if TC mode or 4-wire linear RTD
x	0	x	Input scale and offset not used
x	1	x	Input scale and offset used
0	x	x	No ratio measurements (only in Bridge or Pot)
1	x	x	Ratio measurements (only in Bridge or Pot) input

EXAMPLE: The computer tells meter HEX #15 to take direct measurements, to use "IN.SC.OF" values (input scaling and offset to eliminate transmitter span/offset and errors), to use a remote cold junction, to get the input from a transmitter but to linearize for a thermocouple, to be on a unipolar input scale, to use the SLOW read rate, and to optimize for 60 Hz (not important in SLOW, however). The byte is now "01101000" or HEX "68"; the computer sends *15W0A68<CR>. The meter would echo "15W0A<CR>" if "BUS.3=1" had been programmed.

NOTE: "If P0A" is transmitted, meter will go to SOFT RESET (RESET1) after completing communication.

10

Data Formats for Process, Strain Gauge, Temperature, and Universal Meters

10.7 SETTING DECIMAL POINT LOCATION AND ROUNDOFF ("DEC PT", "CNT BY")

This "0C" command suffix encodes these two features in the same byte, MSN for the decimal point and LSN for the roundoff interval:

Table 10.14. Count By ("CNT BY"), Bits 3, 2, 1, and 0

BIT NUMBER				COUNT BY (ROUNDOFF TO)
3	2	1	0	
0	0	0	0	1
0	0	0	1	2
0	0	1	0	5
0	0	1	1	10
0	1	0	0	20
0	1	0	1	50
0	1	1	0	100

Table 10.15. Decimal Point ("DEC PT"), Bits 7, 6, 5, and 4

BIT NUMBER				DECIMAL POINT
7	6	5	4	
0	0	0	0	NONE
0	0	0	1	FFFFFF.
0	0	1	0	FFFFFF.F
0	0	1	1	FFFF.FF
0	1	0	0	FFF.FFF
0	1	0	1	FF.FFFF
0	1	1	0	F.FFFFF

EXAMPLE: The computer wants to set meter #15 hex to center the decimal point and count-by-10. It transmits "*15P0C43<CR>".

These data are put into EEPROM by using "W", and can be read from the RAM or EEPROM by "G" or "R": For example, commanding "*15G0C<CR>" elicits the meter response of "15R0C43<CR>" for the above configuration when a command-echo is programmed.

10

Data Formats
for Process,
Strain Gauge,
Temperature,
and Universal
Meters

10.8 FILTER CONFIGURATION AND NUMBER OF SAMPLES IN THE AVERAGE ("FILCNF", "FIL TI")

This "OE" command suffix uses just one byte, MSN for filter type and where used, LSN for the (maximum) number of samples to be averaged into the filtered value.

The choice of ABC (adaptive filter, # samples in the average drops if signal motion is detected), fixed filter (# samples does not change), or no filter for the display and the analog output (option) are shown in Tables 10.16 and 10.17.

"x" is used to show either "1" or "0".

Table 10.16. Filter Time Constant ("FIL TI") bits 3, 2, 1 and 0

BIT NUMBER				(MAXIMUM)
3	2	1	0	# SAMPLES/AVERAGE
0	0	0	0	1 (unfiltered)
0	0	0	1	2
0	0	1	0	4
0	0	1	1	8
0	1	0	0	16
0	1	0	1	32
0	1	1	0	64
0	1	1	1	128

Table 10.17. Filter Configuration ("FILCNF") Bits 7, 6, 5, and 4

BIT NUMBER				SELECTS
7	6	5	4	
x	x	x	0	ABC filter type
x	x	x	1	Normal filter type
x	x	0	x	Reading value used on display
x	x	1	x	Filtered value used on display
0	0	x	x	Unfiltered value to Analog output
0	1	x	x	Filtered value to Analog output
1	0	x	x	Peak value to Analog output
1	1	x	x	Valley value to Analog output

10

Data Formats for Process, Strain Gauge, Temperature, and Universal Meters

10

Data Formats
for Process,
Strain Gauge,
Temperature,
and Universal
Meters

EXAMPLE: The computer requests the EEPROM filter values from meter #15 hex: `"*15R0E<CR>"`, and the meter responds (with echo): `"15R0E67<CR>"`, showing that the nonvolatile memory is set to put the adaptive (ABC) filter on both outputs with a maximum number of samples in the average (128).

10.9 SETPOINT 1 AND 2 CONFIGURATION ("SP CNF")

This "10" command suffix encodes the operating modes selected for these two setpoints in one byte (two HEX-ASCII characters):

Table 10.18. Setpoint 1 Configuration ("SP CNF"), Bits 2, 1, and 0

BIT NUMBER			CONFIGURATION
2	1	0	
x	x	0	SP 1 active above
x	x	1	SP 1 active below
x	0	x	Out transistor #1 on if SP 1 active
x	1	x	Out transistor #1 off if SP 1 active
0	x	x	SP 1 uses unfiltered value
1	x	x	SP 1 driven from filtered value

Table 10.19. Setpoint 2 Configuration ("SP CNF"), Bits 5, 4, and 3

BIT NUMBER			CONFIGURATION
5	4	3	
x	x	0	SP 2 active above
x	x	1	SP 2 active below
x	0	x	Out transistor #2 on if SP 1 active
x	1	x	Out transistor #2 off if SP 1 active
0	x	x	SP 2 uses unfiltered value
1	x	x	SP 2 driven from filtered value

Table 10.20. Setpoint Configuration ("SP CNF"), Bits 7, and 6

BIT NUMBER		CONFIGURATION
7	6	
x	0	Enable SP 1 and SP 2
x	1	Disable SP 1 and SP 2
0	x	Enable LEDs 1 and 2
1	x	Disable LEDs 1 and 2

EXAMPLE: The computer requests the SP 1 and 2 status from the RAM of meter #15 hex with:

"*15G10<CR>", and the meter responds without echo: "2F<CR>", indicating that:

Setpoint 1 and its LED are enabled, active below, driven by the filtered measurements, with its transistor active when that SP is OFF, and

Setpoint 2 and its LED are enabled, active below, driven by the filtered measurements, with its transistor active when that SP is ON.

10.10 ALARM (SETPOINTS 3 AND 4) CONFIGURATION ("AL CNF")

The encoding of the byte for this "11" command suffix is identical with that immediately above for SP 1 and 2 except that the most significant bit does not allow the LED to be turned off when an alarm is ON (set this bit to "0", i.e., keep the MSN under 8).

Table 10.21. Alarm 1 (SP 3) Configuration ("AL CNF"), Bits 2, 1, and 0

BIT NUMBER			CONFIGURATION
2	1	0	
x	x	0	AL 1 (SP 3) active above
x	x	1	AL 1 (SP 3) active below
x	0	x	Out transistor #3 on if AL 1 (SP 3) is active
x	1	x	Out transistor #3 off if AL 1 (SP 3) active
0	x	x	AL 1 uses unfiltered value
1	x	x	AL 1 driven from filtered value

Table 10.22. Alarm 2 (SP 4) Configuration ("AL CNF"), Bits 5, 4, and 3

BIT NUMBER			CONFIGURATION
5	4	3	
x	x	0	AL 2 (SP 4) active above
x	x	1	AL 2 (SP 4) active below
x	0	x	Out transistor #4 on if AL 2 (SP4) active
x	1	x	Out transistor #4 off if AL 2 (SP4) active
0	x	x	AL 2 uses unfiltered value
1	x	x	AL 2 driven from filtered value

10

Data Formats for Process, Strain Gauge, Temperature, and Universal Meters

10

Data Formats
for Process,
Strain Gauge,
Temperature,
and Universal
Meters

Table 10.23. Alarm Configuration ("AL CNF"), Bits 7 and 6

BIT NUMBER		CONFIGURATION
7	6	
x	0	Enable AL 1 and AL 2
x	1	Disable AL 1 and AL 2
0	x	Alarm reset at pin P2-11 disabled
1	x	Alarm reset at pin P2-11 enabled

NOTE: Pin P2-11 is shared with the external print command (Refer to "BUS FT" in Section 10.19).

10.11 ALARM FUNCTIONS ("AL FNC")

The "12" command suffix encodes the controls for Alarm 1 (SP 3) in the LSN and for Alarm 2 (SP 4) in the MSN of the data byte:

Table 10.24. Alarm 1 Function ("AL FNC"), Bits 3, 2, 1 and 0

BIT NUMBER				ALARM 1 (SP 3) CONFIGURATION
3	2	1	0	
0	x	0	0	Process (no deviation)
0	x	0	1	High deviation
0	x	1	0	Low deviation
0	x	1	1	Band deviation
0	0	x	x	Unlatched Alarm
0	1	x	x	Latched Alarm

Table 10.25. Alarm 2 Function ("AL FNC"), Bits 7, 6, 5 and 4

BIT NUMBER				ALARM 2 (SP 4) CONFIGURATION
7	6	5	4	
0	x	0	0	Process (no deviation)
0	x	0	1	High deviation
0	x	1	0	Low deviation
0	x	1	1	Band deviation
0	0	x	x	Unlatched Alarm
0	1	x	x	Latched Alarm

EXAMPLE: The computer wants the alarms of meter #15 HEX both latching, with Alarm 1 high deviation and Alarm 2 band deviation. The message is:

"*15P1275<CR>", and the meter would echo "15P12<CR>" if "BUS.3=1" had been set.

10.12 ALARM DELAY: ("AL RDG")

This "33" command suffix data is straight forward binary coding of the number of alarm readings before alarm activation, using MSN and LSN for Alarm 1 (SP 3) and Alarm 2 (SP 4) respectively.

Table 10.26. Alarm 1 and 2 Delay

BIT NUMBER				# OF ALARMS BEFORE ALARM IS ACTIVE
3/7	2/6	1/5	0/4	
0	0	0	0	0
0	0	0	1	1
0	0	1	0	2
0	0	1	1	3
0	1	0	0	4
0	1	0	1	5
0	1	1	0	6
0	1	1	1	7
1	0	0	0	8
1	0	0	1	9
1	0	1	0	10
1	0	1	1	11
1	1	0	0	12
1	1	0	1	13
1	1	1	0	14
1	1	1	1	15

NOTE: Bits 0 through 3 belong to Alarm 2

NOTE: Bits 4 through 7 belong to Alarm 1

EXAMPLE: The computer tells meter #15 hex to alarm at once with Alarm 1 (SP 3) but to delay for 10 readings on Alarm 2 (SP 4): "***15W130A<CR>**", writing to EEPROM (this needs a RESET2 to be copied into RAM and affect current alarm operation).

10

Data Formats
for Process,
Strain Gauge,
Temperature,
and Universal
Meters

10

Data Formats
for Process,
Strain Gauge,
Temperature,
and Universal
Meters

10.13 SETPOINT 1 AND 2 HYSTERESIS ("SP DB")

Command Suffix "14" uses two bytes (four nibbles, or four characters) for this binary positive-only value. Both setpoints use this same hysteresis, applied 50% on either side of the respective setpoint. This value is not kept in RAM (only in the EEPROM), so that only "R" and "W" commands apply.

EXAMPLE: If the computer wants to know the hysteresis value stored by meter #15 hex, it sends:

"*15R14<CR>", to which the meter replies:
"15R141A90<CR>" if it was programmed to echo with "BUS.3=1"
and had decimal hysteresis of 6,800 counts.

NOTE: Maximum allowable value for hysteresis is 9999 counts.

10.14 ALARM (SP 3 AND SP 4) HYSTERESIS ("AL DB")

Identical with Section 10.13, suffix "15" commands use two bytes (four characters) for this binary positive-only value. Both alarms use this same hysteresis, applied 100% on the inactive side of the respective alarm point (setpoint), so that you get fast alarm action and slower exit from that alarm. This value is not kept in RAM; "R" and "W" interact with the EEPROM.

EXAMPLE: The computer sends "*15W1A90<CR>", giving both alarms the hysteresis value of hex 6800 Counts.

NOTE: Maximum allowable value for hysteresis is 9999 counts.

10.15 OUTPUT CONFIGURATION AND DISPLAY FLASHING CONTROLS ("OUT.CNF")

Two nibbles are used to carry the "16" command-suffix information:

Table 10.27. Output Configuration ("OUT.CNF") Bits 4, 3, 2, 1, and 0

BIT NUMBERS					SELECTS
4	3	2	1	0	
x	x	x	x	0	Analog output disabled
x	x	x	x	1	Analog output enabled
x	x	x	0	x	0-10 V output
x	x	x	1	x	0-20 mA output
x	x	0	x	x	Parallel BCD disabled
x	x	1	x	x	Parallel BCD enabled
x	0	x	x	x	BCD driven by display value
x	1	x	x	x	BCD driven by PEAK value
0	x	x	x	x	Large or desktop printers
1	x	x	x	x	Panel printers

Table 10.28. Output Configuration ("OUT.CNF") Bits 7, 6, and 5

BIT NUMBER			CONFIGURATION
7	6	5	
0	0	0	No display flashing when any setpoint active
0	0	1	Display flash for SP 1
0	1	0	Display flash for SP 2
0	1	1	Display flash for SP 3
1	0	0	Display flash for SP 4
1	0	1	Display flashes for any setpoint

"P" or "G" commands can exchange this status with the RAM, while "W" or "R" commands can exchange with the nonvolatile EEPROM (where a subsequent "RESET2" command moves these data into RAM as well).

EXAMPLE: If the computer sends "*15W165D<CR>", it writes into the meter EEPROM that the display should flash for SP 2, that it is to drive a panel printer, that both 0-10 V Analog Output and Parallel BCD are to be driven, and with BCD showing the PEAK values.

10

Data Formats for Process, Strain Gauge, Temperature, and Universal Meters

10.16 SERIAL COMMUNICATIONS CONFIGURATION ("SER.CNF")

This "18" command suffix has one byte (2 nibbles, in two characters) of data. (This information may already have been entered by pushbutton or diskette. It resides only in EEPROM, so that only "R/W" command letters apply.)

10

Data Formats
for Process,
Strain Gauge,
Temperature,
and Universal
Meters

Table 10.29. Serial Configuration ("SER.CNF") Bits 3, 2, 1, and 0

BIT NUMBER				SELECTS
3	2	1	0	
0	0	0	0	Baud rate = 300
0	0	0	1	Baud rate = 600
0	0	1	0	Baud rate = 1200
0	0	1	1	Baud rate = 2400
0	1	0	0	Baud rate = 4800
0	1	0	1	Baud rate = 9600
0	1	1	0	Baud rate = 19200

Table 10.30. Serial Configuration ("SER.CNF") Bits 7, 6, 5, and 4

BIT NUMBER				ALARM 2 (SP 4) CONFIGURATION
7	6	5	4	
x	x	0	0	No parity (automatically reset to two stop bits to get ten-bit characters)
x	x	0	1	Odd parity
x	x	1	0	Even parity
x	x	1	1	Not used
x	0	x	x	One stop bit
x	1	x	x	Two stop bits

EXAMPLE: The computer sends "*15W1856<CR>"; this writes into the EEPROM memory of meter #15 hex "two stop bits, odd parity, 19200 baud". The meter will switch to these choices whenever a hard reset is initiated ("RESET2"). If "BUS.3=1" has been entered, the meter responds with "15W18<CR>".

10.17 RS-485 METER "ADDRESS"

This "1A" command suffix uses 2 HEX-ASCII characters for the device address, but that number is limited to the 1 to 199 decimal range (many more numbers than the 32-device hardware limit).

EXAMPLE: The computer wants to renumber meter #15 HEX (#21 decimal) to #25 HEX (#37 decimal); it then puts the new address into EEPROM with:

*15W1A25<CR>

Which, if "BUS.3=1", would be echoed by the meter with "15W1A<CR>".

This new address would then be put into action by giving the meter a hard reset, "RESET2", from the front-panel, by external contact closure (see Section 10.18), or by sending the reset with: "**15Z04<CR>".

That meter will no longer answer to the "15" hex address; it now responds commands preceded by "*25".

10.18 DATA FORMAT ("DAT FT")

The "1B" command suffix uses two nibbles of data to describe how the meter will respond to the "V01" command, as explained in Appendix A ("DAT.8" is the MSB).

"x" is used to show either "1" or "0".

Table 10.31. Data Format ("DAT FT"), Bits 3, 2, 1, and 0

BIT NUMBER				SELECTS
3	2	1	0	
x	x	x	0	Do not send Alarm Status
x	x	x	1	Send Alarm Status Char
x	x	0	x	Do not send PEAK/VALLEY status
x	x	1	x	Send PEAK/VALLEY status
x	0	x	x	Do not send current reading value
x	1	x	x	Send current reading value
0	x	x	x	Do not send filtered reading value
x	x	x	x	Send filtered reading value

Table 10.32. Data Format ("DAT FT"), Bits 7, 6, 5, and 4

BIT NUMBER				SELECTS
7	6	5	4	
x	x	x	0	Don't send PEAK value
x	x	x	1	Send PEAK
x	x	0	x	Don't send VALLEY value
x	x	1	x	Send VALLEY
x	0	x	x	Use space as separator
x	1	x	x	Use <CR> as separator
0	x	x	x	Don't send units of measure
1	x	x	x	Send units of measure

10

Data Formats for Process, Strain Gauge, Temperature, and Universal Meters

10

Data Formats
for Process,
Strain Gauge,
Temperature,
and Universal
Meters

EXAMPLE: If you don't want PEAK, VALLEY or units-of-measure and do want just <SP> between Alarm Status Character, the unfiltered measurement and the filtered value, the MSN above is "0" and the LSN is "9", so the command to meter #15 HEX is "**15W1B09<CR>".

This puts this format into EEPROM; to move this into RAM for immediate use, also send "**15Z04<CR>" (Hard Reset).

10.19 COMMUNICATIONS BUS FORMAT ("BUS FT")

The "1C" command suffix data is the byte of "BUS FT", programmed in Appendix A.

"x" is used to show either "1" or "0".

Table 10.33. Bus Format ("BUS FT"), Bits 3, 2, 1, and 0

BIT NUMBER				SELECTS
3	2	1	0	
x	x	x	0	Excludes checksum with reading
x	x	x	1	Includes checksum with reading
x	x	0	x	No line feed
x	x	1	x	Line feed following all <CR>
x	0	x	x	No echo
x	1	x	x	Echo response
0	x	x	x	Point-to-point mode
1	x	x	x	Multipoint mode

RS-232 is selected if the most-significant nibble has a value less than 4, and you can select either continuous data transmission or transmission on command, and either RTS control of each character or each message:

Table 10.34. Bus Format ("BUS FT"), Bits 5 and 4

BIT NUMBER		SELECTS RS-232 WITH
5	4	
0	0	Continuous mode with RTS message handshake
0	1	Command mode
1	0	Continuous mode with RTS character handshake
1	1	Command mode

Table 10.35. Bus Format ("BUS FT"), Bits 7 and 6

BIT NUMBER		FUNCTION
7	6	
x	0	RS-485 board not installed
x	1	RS-485 board installed
0	x	External print command on P2-11 disabled*
1	x	External print command on P2-11 enabled*

* P2-11 is shared with alarm reset command (Refer to Section 10.10, Table 10.22)

The least-significant nibble of "BUS FT" should have the two least-significant bits set to zero (reserved for future checksum/line feed features). The other two bits select point-to-point/multipoint operation (RS-232 point-to-point, RS-485 either one), and meter silence or echo of commands.

EXAMPLE: The computer inquires as to the program stored in the EEPROM of meter #15 hex with:

"*15R1C<CR>", and the meter replies:

"15R1C5C<CR>", which states that it is set for multipoint command mode with echo (since this command was echoed, you could tell that it was in the echo mode; since multipoint is always in the command mode, that status was known as well).

10.20 NUMBER OF READINGS BETWEEN EACH TRANSMISSION ("SER CNT")

The "1D" command suffix data is the number of readings between transmissions; this is used only for point-to-point continuous transmission. Four nibbles (2 bytes or 4 HEX-ASCII characters) are used; overflow detection limits the number of readings between transmissions to 59999 (decimal).

"1D" values reside only in EEPROM, so only "R/W" command letters apply.

10

Data Formats for Process, Strain Gauge, Temperature, and Universal Meters

10

Data Formats
for Process,
Strain Gauge,
Temperature,
and Universal
Meters

EXAMPLE: If you were on SLOW (approximately 3 readings/second) and wanted a transmission every hour, the number of readings between transmissions would be approximately $3*60*60 = 10800$, or hex 2A30: to tell the meter, send:

****W1D2A30<CR>**, which places the 2A30 into the EEPROM memory of the meter (add a Hard Reset, ****Z04<CR>** to move this into RAM). If you have set **"BUS.3=1"**, the meter will echo **"W1D<CR>"**.

10.21 RECOGNITION CHARACTER

You can change the security code for commands with this **"IE"** command suffix; the ASCII table address (two HEX-ASCII characters) of the selected character is transmitted.

Valid character addresses are from 20 hex to 7F hex (32 to 127 decimal) with the exception of **"A"**, **"a"**, **"E"** characters.

EXAMPLE: To change the recognition character from **"*"** to **"!"** for all meters on the bus, send:

****00W1E21<CR>**, which puts that new code into EEPROM (but not automatically into RAM), followed by ****00Z04<CR>**, which gives a hard reset to all the meters, moving the new code into RAM. All meters will now ignore commands preceded by **"*"**, and recognize those preceded with **"!"**.

10.22 UNITS OF MEASURE

When instructed with this **"IF"** command suffix, the meter will label its transmitted values with three letters representing the units of the measured quantity (these are for screen or printer labels, not for the meter display; the right-hand digit F, C or K units for temperature are selected by **"RDG.CNF"**, Section 10.3).

Each letter is represented by the two HEX-ASCII characters giving its ASCII table address, from **"41"** to **"79"** (all upper and lower case letters) or the **<SP>** address, **"20"**, for a total of six transmitted characters (do not select any control characters for units-of-measure).

When the desired units-of-measure to be printed have fewer than 3 characters, send the **<SP>** address (**"20"**) to put the blank(s) in the chosen spot(s).

Note that the units-of-measure letters transmitted in the "V01" response are in plain ASCII (one character each) in contrast with this command, where the six characters of the addresses are sent.

EXAMPLE: The computer requests the RAM setting for the measurements underway at meter #15 hex with: "*15G1F<CR>", and that meter, if "BUS.3=1", responds with:

"15G1F6B5061<CR>"; the <data> here are "6B5061", which is HEX-ASCII for "kPa" (kiloPascals).

NOTE: "00" is equivalent to "nul" and meter will transmit nothing for units of measure if the first character is "0".

10.23 TX/RX TURNAROUND DELAY (SERIAL DELAY)

The four choices provided by the meter for this "20" command suffix only need two bits of storage, but the standard byte (two nibbles) is used, so that the MSN = 0.

Turn-around delay is normally used on half-duplex systems (e.g., RS-485), not on full duplex (for the meter, RS-232 or RS-422), but the chosen amount is applied to any of these by the meter. The delay can be useful in eliminating the effects of ringing, reflections or line drop.

Table 10.36. Serial Delay ("SER.DLY")

BIT NUMBER		MILLISECONDS OF TURNAROUND DELAY
0	0	0
0	1	30
0	2	100
0	3	300

EXAMPLE: The computer wants meter #15 hex to use a turn-around delay of 100 milliseconds:

"*15W2002<CR>", and if set for echo with "BUS.3=1", the meter replies:

"15W20<CR>". If point-to-point (only one meter), the "15" address is not used. The chosen delay is now stored in the EEPROM. To put it into use (move to RAM), send a hard reset, "*15Z04<CR>".

10

Data Formats for Process, Strain Gauge, Temperature, and Universal Meters

10.24 SETPOINT VALUE ("SP1", "SP2", "SP3", "SP4")

Command suffixes "21", "22", "23" and "24" set the value of Setpoints 1, 2, 3 and 4 respectively (the last two often used as Alarm 1 and 2). Each setpoint is described by three bytes (six HEX-ASCII characters), with the sign and decimal point encoded in the MSN:

(Here, "FFFFFF" represents the 6 displayed decimal digits, the magnitude of the 20 least-significant bits of these 3 bytes.)

1. Bits 0 to 19 belong to the absolute value (99999 for negative values and 999999 for positive values)
2. Bits 20, 21, 22 belong to the decimalpoint as in Table 10.37
3. Bit 23 belongs to sign where 0 is positive and 1 is negative as in Table 10.37

Table 10.37. Setpoint Values, Bits 23, 22, 21, and 20

BIT PATTERN				SIGN AND DECIMAL POINT
23	22	21	20	
0	0	0	0	Not used
0	0	0	1	+FFFFFF.
0	0	1	0	+FFFFF.F
0	0	1	1	+FFFF.FF
0	1	0	0	+FFF.FFF
0	1	0	1	+FF.FFFF
0	1	1	0	+F.FFFFF
0	1	1	1	Not used
1	0	0	0	Not used
1	0	0	1	-FFFFFF.
1	0	1	0	-FFFFF.F
1	0	1	1	-FFFF.FF
1	1	0	0	-FFF.FFF
1	1	0	1	-FF.FFFF
1	1	1	0	-F.FFFFF
1	1	1	1	Not used

The following 5 nibbles (HEX-ASCII characters) give the binary magnitude.

10

Data Formats
for Process,
Strain Gauge,
Temperature,
and Universal
Meters

NOTE: Since Setpoint value decimal point is directly related to the system decimal point (see Section 10.7), select the same decimal for setpoints as selected for system decimal point.

EXAMPLE: The computer inquires of meter #15 hex what value for Setpoint #3 is stored in EEPROM (usually the same value as in RAM):
 “*15R23<CR>”, and if set for echo (“BUS.3=1”), the meter replies:

“15R23A12345<CR>”, where the magnitude is “12345” in hex, or “74565” in decimal, and the MSN “A”, from the Table 10.37, sets the final decimal value of Setpoint #3 as “-7456.5”.

10.25 BLOCK READ OR WRITE

A Block consists of more than one item. The data pattern is the union of all individual byte pattern items included in that block and its order is exactly as described in each below:

1. Lock transmit command structure for “P” or “W”:

*[nn]ccc<data>[hh]<CR>

2. Block receive structure for “G” or “R”:

*[nn][ccc]<data>[hh]<CR>[LF]

Note 1: Byte No. 1 is the most significant byte in <data> block.

Note 2: Most significant byte of each item is the first to transmitted or received.

Note 3: If the meter is in “No Echo Mode”, [nn][ccc] will be omitted from receive data format.

Note 4: One byte is equal to two ASCII characters.

The following table of Block Command prefixes and suffixes is for Process, Strain Gauge, Temperature and Universal Meters.

Table 10.38

BLOCK	COMMAND PREFIX	COMMAND SUFFIX (HEX)
A	R,W	40
B	R,W	41
C	R,W	42

NOTE: R,W means “R” or “W”

10

Data Formats
for Process,
Strain Gauge,
Temperature,
and Universal
Meters

10

Data Formats
for Process,
Strain Gauge,
Temperature,
and Universal
Meters

10.25.1 BLOCK A

This block consists of ten (10) items and thirty bytes (60 ASCII characters) as Table 10.39:

Table 10.39. Block A

(HEX ITEM SUFFIX)	DESCRIPTION	BYTE NO. & ORDER
26	Analog Out Offset	1, 2, 3
17	Analog Out Scale	4, 5, 6
25	Input Offset	7, 8, 9
0B	Input Scale	10, 11, 12
09	Display Offset	13, 14, 15
08	Display Scale	16, 17, 18
24	Setpoint 4 Value	19, 20, 21
23	Setpoint 3 Value	22, 23, 24
22	Setpoint 2 Value	25, 26, 27
21	Setpoint 1 Value	28, 29, 30

10.25.2 BLOCK B

This block consists of 17 items and 19 bytes (38 ASCII characters) as Table 10.40:

Table 10.40. Block B

(HEX ITEM SUFFIX)	DESCRIPTION	BYTE NO. & ORDER
1E	Recognition Character	1
1F	Units of Measure	2, 3, 4
20	Turnaround Delay	5
1A	RS-485 device #	6
18	Communications Configuration	7
13	# readings delayed Alarms	8
12	Alarm function	9
11	Control Setpoints 3 and 4	10
10	Control Setpoints 1 and 2	11
15	Input type and range	12
0C	DEC PT and CNT BY	13
16	Analog Out Configuration	18
07	Display Controls	15
1C	Bus format	16
1B	Data Format	17
0E	Filter Configuration	18
0A	Input Configuration	19

10.25.3 BLOCK C

This block consists of 7 items and 10 bytes (20 ASCII characters) as Table 10.41:

Table 10.41. Block C

(HEX ITEM SUFFIX)	DESCRIPTION	BYTE NO. & ORDER
1D	# of rdg Print Spac	1, 2
15	Alarm Hysteresis	3, 4
14	Setpoint Hysteresis	5, 6
04	Lockout Byte #4	7
03	Lockout Byte #3	8
02	Lockout Byte #2	9
01	Lockout Byte #1	10

10.25.4 EXAMPLE:

Assuming echo mode; no line feed; checksum; and point-to-point mode.

1. Read Block C from EEPROM

a) And send to the meter:

*R42<CR>

b) Response from the meter:

1. # of readings between each transmission = 2711 (HEX)
2. Alarm Hysteresis = 0001 (HEX)
3. Set Pt Hysteresis = 0001 (HEX)
4. Lockout #4 = E0 (HEX)
5. Lockout #3 = 3E (HEX)
6. Lockout #2 = 00 (HEX)
7. Lockout #1 = 3F (HEX)

2. Write Block C on to EEPROM.

a) Command sent to the meter:

*W42271100010001E03E003F<CR>;

b) Response from the meter:

W42<CR>

IMPORTANT NOTE: Before sending data to the meter, each nibble of data has to be converted to an ASCII character.

10-29

10

Data Formats
for Process,
Strain Gauge,
Temperature,
and Universal
Meters

11. Data Formats Associated with Commands for Rate Meter/Totalizers and Batch Meters

This section introduces data formats in detail. The following conditions are assumed in the text and in examples:

1. The recognition character is the asterisk (*).
2. The meter address is 15 HEX (21 decimal).
3. When any **W** command is given, a reset is necessary to initiate the command.
4. The meter is in ECHO mode—it echoes the address and Command Index.

11.1 LOCKOUT BYTES ("L1 CNF", "L2 CNF", "L3 CNF")

"G," "P," "R" or "W" followed by "06", "07", or "08", send to RAM/EEPROM or receive from RAM/EEPROM the 8 bits of each of the three lockout bytes.

EXAMPLE: We want to send a value of "01011010" for L2 CNF into the EEPROM of the meter number 15. Equivalent HEX value is "5A", so the computer sends "*15W075A<CR>".

The meter would echo the command with "15W07<CR>" if "BUS.3=1".

Below is the bit pattern corresponding to the lockout bytes.

NOTE: Each Lockout is one byte (8 bits) where:

L1C.1 is bit 0 of Lockout #1
L1C.8 is bit 7 of Lockout #1

Each item on the left will lock out following item on the right.

11

Data Formats
for
Rate Meter/
Totalizers
and Batch
Meters

Table 11.1. Lockouts

LOCKOUT	FUNCTION	CORRESPONDING ITEM
L1 CNF:		LOCKOUT CONFIGURATION #1
L1C.1 = 0	Unlocked	Display of Setpoints 1 and 2 through SETPTS button
= 1	Locked	
L1C.2 = 0	Unlocked	Display of Setpoints 3 and 4 through SETPTS button
= 1	Locked	
L1C.3 = 0	Unlocked	Display of Setpoint 5 through SETPTS button
= 1	Locked	
L1C.4 = 0	Unlocked	Display of CNFG 1 parameter
= 1	Locked	
L1C.5 = 0	Unlocked	Display of CNFG 2 parameter
= 1	Locked	
L1C.6 = 0	Unlocked	Display of CNFG 3 parameter
= 1	Locked	
L1C.7 = 0	Unlocked	Display of CNFG 4 parameter
= 1	Locked	
L1C.8 = 0	Unlocked	Display of AVG.CNF parameter in Rate or Sq Rt Modes
= 1	Locked	
L2CNF		LOCKOUT CONFIGURATION #2
L2C.1 = 0	Unlocked	Display of IN.SC.OF parameter
= 1	Locked	
L2C.2 = 0	Unlocked	Display of OT.SC.OF parameter
= 1	Locked	
L2C.3 = 0	Unlocked	Display of RTE DP, RTE OF, RTE SC, BAT DP, B LOAD, and BAT SC parameters
= 1	Locked	
L2C.4 = 0	Unlocked	Display of TOT DP, TOT OF, and TOT SC parameters
= 1	Locked	
L2C.5 = 0	Unlocked	Display of AL TI parameter
= 1	Locked	
L2C.6 = 0	Unlocked	Display of BAUD, SER.CNF, DAT FT, BUS FT, ADDRES, and SER TI parameters
= 1	Locked	
L2C.7 = 0	Unlocked	Display of SET TI parameter
= 1	Locked	
L2C.8 = 0	Unlocked	Display of GATE T parameter
= 1	Locked	

continued next page

11

Data Formats
for
Rate Meter/
Totalizers
and Batch
Meters

LOCKOUT	FUNCTION	CORRESPONDING ITEM
L3 CNF:		LOCKOUT CONFIGURATION #3
L3C.1 = 0	Unlocked	Display of RATE, SQ RT, and BATCH through DISPLAY button in Run Mode
= 1	Locked	
L3C.2 = 0	Unlocked	Display of AVG RT, and BAT NO through DISPLAY button in Run Mode
= 1	Locked	
L3C.3 = 0	Unlocked	Display of TOTAL through DISPLAY button in Run Mode
= 1	Locked	
L3C.4 = 0	Unlocked	Display of TIME through DISPLAY button in Run Mode
= 1	Locked	
L3C.5 = 0	Unlocked	Display of MODE parameter
= 1	Locked	
L3C.6 = 0	Unlocked	Display of CAL VZ, CAL VS, CALmAZ, and CALmAS parameters
= 1	Locked	
L3C.7 = 0	Unlocked	EEPROM storage of changed settings
= 1	Locked	
L3C.8 = 0	Unlocked	MENU button (disabled only with removal of S1A)
= 1	Locked	

11.2 MODE

Mode is one byte of data (2 characters). It uses the prefixes G, R, and W with the suffix 07. This byte controls the operating mode of the meter as follows:

- 0: Batch Mode
- 1: Rate Mode
- 2: Sq Rt Mode

The default value is 0, Batch Mode.

EXAMPLE: To set the mode to Rate for meter #15, send the command *15W0701<CR>. The meter will respond with 15W07<CR>. To reset the meter, send the command 15Z05<CR>. The meter will respond with 15Z05<CR>.

11.3 DISPLAY MODE

This item is 1 byte (2 characters). It uses command prefixes G and P with the suffix 33, allowing you to read or change the meter's display mode.

11

Data Formats
for
Rate Meter/
Totalizers
and Batch
Meters

a) The bit pattern in response to a G33<CR> command is as follows:

Table 11.2. Display Mode Bits

BIT NO.	VALUE	FUNCTION	
		RATE AND SQ RT MODES	BATCH MODE
0 - 2	0	Not used (Defaults to 1)	Not used (Defaults to 1)
	1	RATE is displayed	BATCH is displayed
	2	AVG RT is displayed	No. of BATCHes is displayed
	3	TOTAL is displayed	TOTAL is displayed
	4	TIME is displayed	TIME is displayed
3-6	0	Not used	Not used
	1	Not used	Not used
7	0	Not used	RUN mode
	1	Not used	Stop mode (meter is in STOP mode)

b) Bit pattern for a P 33 command data format:

BIT NO.	VALUE	FUNCTION	
		RATE AND SQ RT MODES	BATCH MODE
0 - 2	0	Not used (Defaults to 1)	Not used (Defaults to 1)
	1	Puts RATE on display	Puts BATCH on display
	2	Puts AVG RT on display	Puts No. BATCHes on display
	3	Puts TOTAL on display	Puts TOTAL on display
	4	Puts TIME on display	Puts TIME on display
	5,6,7	Not used	Not used
3-7		Not used- Set to zero	Not used- Set to zero
		Not used	Not used

11

Data Formats
for
Rate Meter/
Totalizers
and Batch
Meters

EXAMPLE: In RATE MODE, you want to change the display, which is currently showing a rate value, to display TOTAL on meter #15.

Send command: "15P3303<CR>"

Meter will send back this message: "15P33<CR>" and change its display to show "TOTAL"

11.4 CONFIGURATION 1 ("CNFG 1")

This item is 1 byte (2 characters). It uses command prefixes G, P, R, and W with the suffix 0A. The bit pattern is as follows:

Table 11.3 Configuration 1 ("CNFG 1") Bits

BIT NO.	VALUE	FUNCTION	
		RATE AND SQ RT MODES	BATCH MODE
0	0	Out transistor 1 is on if SP 1 is active	
	1	Out transistor 1 is off if SP 1 is active	
1	0	Out transistor 2 is on if SP 2 is active	
	1	Out transistor 2 is off if SP 2 is active	
2	0	Out transistor 3 is off if SP 3 is active	
	1	Out transistor 3 is on if SP 3 is active	
3	0	Out transistor 4 is on if SP 4 is active	
	1	Out transistor 4 is off if SP 4 is active	
4	0	Out transistor 5 is on if SP 5 is active	
	1	Out transistor 5 is off if SP 5 is active	
5	0	Display is set to full brightness	
	1	Display is set to 50% brightness	
6	0	SP 3 is assigned to RATE	SP 4 is assigned to TOTAL
	1	SP 3 is assigned to AVG RT	SP 4 is assigned to BAT NO
7	0	SP 4 is assigned to RATE	BATCH value counts up
	1	SP 4 is assigned to AVG RT	BATCH value counts down

11

Data Formats
for
Rate Meter/
Totalizers
and Batch
Meters

EXAMPLE: In Rate Mode, you want Setpoints 1, 3, and 4 to be active high, and Setpoints 2 and 5 to be active low. You also want the display to be set to full brightness, Setpoint 3 to be assigned to RATE, and Setpoint 4 to be assigned to "AVT RT" (Average Rate).

These settings correspond to a binary value of 10010010 = 92 Hex.

To write these values to RAM of meter #15, send the command *15P0A92<CR>. The meter will respond with 15P0A<CR>.

11.5 CONFIGURATION 2 ("CNFG 2")

This item is 1 byte (2 characters). It uses command prefixes G, P, R, and W with the suffix 0B. The bit pattern is as follows:

Table 11.4. Configuration 2 ("CNFG 2") Bits

BIT NO.	VALUE	FUNCTION	
		RATE AND SQ RT MODES	BATCH MODE
0	0	SP 1 is active above	
	1	SP 1 is active below	
1	0	SP 2 is active above	
	1	SP 2 is active below	
2	0	SP 3 is active above	
	1	SP 3 is active below	
3	0	SP 4 is active above	
	1	SP 4 is active below	
4	0	SP 5 is active above	
	1	SP 5 is active below	
5	0	SP 3 action is not delayed	Reset action is normal (manual)
	1	SP 3 action is delayed for 4 alarm readings	At SP 3, meter auto resets to 0; or at 0 resets to SP 3 (if Batch value is count down).
6	0	SP 4 action is not delayed	BAT NO counts up
	1	SP 4 action is delayed for 4 alarm readings	BAT NO counts down from SP 4 if Bit No. 6 in CNFG 1 (Section 11.4) is set.
7	0	Meter is set for 60 Hz power	
	1	Meter is set for 50 Hz power	

11

Data Formats for
Rate Meter/
Totalizers
and Batch
Meters

EXAMPLE: You want Setpoints 1, 2, and 3 to be active above, and Setpoints 4 and 5 to be active below. You also want to use the auto reset action, have the BAT NO count down, and set the meter for 50 Hz.

These settings correspond to a binary value of 11111000 = F8 HEX.

To write these values to EEPROM of meter #15, send the command *15W0BF8<CR>. The meter will respond with 15W0B<CR>.

11.6 CONFIGURATION 3 ("CNFG 3")

This item is 3 bytes (6 characters). It uses command prefixes G, P, R, and W with the suffix 0C. The bit pattern is as follows:

1) Most significant byte (Byte 3)

Table 11.5. Configuration 3 ("CNFG 3"), Byte 3

BIT NO.	VALUE	FUNCTION	
		RATE AND SQ RT MODES	BATCH MODE
0 - 3	0	Analog Output disabled	Analog Output disabled
	1	RATE is sent to analog output	BATCH value is sent to analog output
	2	AVG RT is sent to analog output	BAT NO is sent to analog output
	3	TOTAL is sent to analog output	TOTAL is sent to analog output
4 - 7	4	Output is ramped (time proportional)	Output is ramped (time proportional)
	0	BCD output disabled	BCD output disabled
	1	RATE is sent to BCD output	BATCH value is sent to BCD output
	2	AVG RT is sent to BCD output	BAT NO is sent to BCD output
	3	TOTAL is sent to BCD output	TOTAL is sent to BCD output
	4	TIME is sent to BCD output	TIME is sent to BCD output

11

Data Formats
for
Rate Meter/
Totalizers
and Batch
Meters

2) Middle Byte (Byte 2)

Table 11.6. Configuration 3 ("CNFG 3"), Byte 2

BIT NO.	VALUE	FUNCTION	
		RATE AND SQ RT MODES	BATCH MODE
0 - 1	0	SP 1 output is normal (unlatched)	
	1	SP 1 output is latched	
	2	SP 1 output is pulsed	
	3	Not used	
2 - 3	0	SP 2 output is normal (unlatched)	
	1	SP 2 output is latched	
	2	SP 2 output is pulsed	
	3	Not used	
4 - 5	0	SP 3 output is normal (unlatched)	
	1	SP 3 output is latched	
	2	SP 3 output is pulsed	
	3	SP 3 output is hysteretic (Hysteresis = SP4-SP3) in Rate/Sq. Rt. Modes (Not applicable in Batch Mode)	
6 - 7	0	SP 4 output is normal (unlatched)	
	1	SP 4 output is latched	
	2	SP 4 output is pulsed	
	3	SP 4 output is hysteretic (Hysteresis = SP4-SP3) in Rate/Sq. Rt. Modes (Not applicable in Batch Mode)	

11

Data Formats
for
Rate Meter/
Totalizers
and Batch
Meters

3) Least significant Byte (Byte 1)

Table 11.7. Configuration 3 ("CNFG 3"), Byte 1

BIT NO.	VALUE	FUNCTION	
		RATE AND SQ RT MODES	BATCH MODE
0 - 1	0	SP 5 output is normal (unlatched)	
	1	SP 5 output is latched	
	2	SP 5 output is pulsed	
	3	Not used	
2 - 3	0	Cutoff frequency disabled: all rates counted	
	1	0 Hz cutoff: only positive rates counted	
	2	100 Hz (5 Hz Sq Rt): rates > 100 Hz (5 Hz SQ RT) counted	
	3	300 Hz (10 Hz Sq Rt): rates > 300 Hz (10 Hz SQ RT) counted	
4 - 5	0	Meter waits 11 s for final pulse	Fast SP #3 response 1-2 ms
	1	Meter waits 2 s for final pulse	Not used
	2	Meter waits 0.5 s for final pulse	Not used
	3	Meter waits 0.15 s for final pulse	SP #3 normal response 10-20 ms
6-7	Not used	Not used	Not used

EXAMPLE: In Rate Mode, you want to output the RATE reading on analog output, the TOTAL reading on BCD output, make Setpoints 1 and 5 unlatched, Setpoint 2 pulsed, Setpoint 3 latched, Setpoint 4 hysteretic, set the time out (waiting time) to 2 s, and use a zero cutoff value.

These settings correspond to the following binary values:

Byte 1 = 00110001 binary = 14 Hex

Byte 2 = 11011000 binary = C8 Hex

Byte 3 = 00010100 binary = 31 Hex

To write these values to RAM of meter #15, send the command *15P0C31C814<CR>. The meter will respond with 15P0C<CR>.

11

Data Formats
for
Rate Meter/
Totalizers
and Batch
Meters

11.7 CONFIGURATION 4 ("CNFG 4")

This item is 1 byte (2 characters). It uses command prefixes G, P, R, and W with the suffix 0D. The bit pattern is as follows:

Table 11.8. Configuration 4 ("CNFG 4") Bits

BIT NO.	VALUE	FUNCTION	
		RATE AND SQ RT MODES	BATCH MODE
0	0	External Reset A triggered on pulse edge	
	1	External Reset A triggered on pulse level	
1	0	Analog output = Voltage mode	
	1	Analog output = Current mode	
2	0	Display hold Disabled	
	1	Display hold Enabled	
3	0	External print request Disabled	
	1	External print request Enabled	
4	0	10 ms output pulse on P2-15 at the beginning of each RATE measurement	Pulse output on P2-15 low when input rate cut off; high if rate not cut off
	1	Pulse out period on P2-15 is programmable via "SER TI" (Refer to Section 11.27). Pulses are low for 70 to 140 milliseconds	
5	0	BCD decimal point is right justified (for desktop printer)	
	1	BCD decimal point is left justified (for specialty printer)	
6	0	Front-panel reset Disabled	
	1	Front-panel reset Enabled	
7	0	Input and Rate Scale and Offset Disabled	Front-panel STOP Disabled
	1	Input and Rate Scale and Offset Enabled	Front-panel STOP Enabled

11

Data Formats
for
Rate Meters/
Totalizers
and Batch
Meters

EXAMPLE: In Batch Mode, you want to trigger the external Reset A on the pulse edge, set the analog output to Current, enable external hold and print request, set the output pulse period to 25 ms, make the BCD decimal compatible with a desktop printer, and disable the front-panel STOP button.

These settings correspond to a binary value of 10011110 = 9E Hex.

To write these values to EEPROM of meter #15, send the command *15W0D9E<CR>. The meter will respond with 15W0D<CR>.

11.8 AVERAGE CONFIGURATION ("AVG.CNF") FOR RATE AND SQUARE ROOT RATE MODES ONLY

This item pertains to Rate and Sq Rt Modes only. It is 1 byte (2 characters) and uses command prefixes G, P, R, and W with the suffix 0E. The bit pattern is as follows:

Table 11.9. Average Configuration ("AVG.CNF") Bits 3 - 0

BIT NO.				NO. OF READINGS IN AVERAGING.
3	2	1	0	
0	0	0	0	1
0	0	0	1	2
0	0	1	0	4
0	0	1	1	8
0	1	0	0	16
0	1	0	1	32
0	1	1	0	64
0	1	1	1	128
1	0	0	0	256

Table 11.10. Average Configuration ("AVG.CNF") Bits 7 - 4

BIT NO.	VALUE	FUNCTION
4	0	Averages with ABC filter
	1	Averages with fixed (normal) filter
5	0	N/A (set to zero)
6	0	N/A (set to zero)
7	0	N/A (set to zero)

EXAMPLE: You want to use the ABC filter and have 128 readings in the average.

These settings correspond to a binary value of 00000111 = 07 Hex.

To write these values to RAM of meter #15, send the command *15P0E07<CR>. The meter will respond with 15P0E<CR>.

11

Data Formats
for
Rate Meter/
Totalizers
and Batch
Meters

11

Data Formats
for
Rate Meter/
Totalizers
and Batch
Meters

11.9 MEASUREMENT TIME ("GATE T") FOR RATE AND SQUARE ROOT RATE MODES ONLY

This item pertains to Rate and Sq Rt Modes only. It is 1 byte (2 characters) and uses command prefixes G, P, R, and W with the suffix 18. The data format is as follows:

Table 11.11. Gate Time ("GATE T") Values

"GATE T" VALUE	GATE TIME IN SECONDS
0	0.03
1	0.10
2	0.30
3	1.00
4	3.00

EXAMPLE: You want the RATE measurement time of your meter to be 1 s. To write this value to RAM of meter #15, send the command *15P1803<CR>. The meter will respond with 15P18<CR>.

11.10 PULSED SETPOINT NUMBER

This item is 1 byte (2 characters). It specifies the single setpoint to which the AL T1 (alarm time or pulse duration- Refer to Section 11.11) parameter pertains. It uses command prefixes G, P, R, and W with the suffix 20. The data format is as follows:

Table 11.12. Pulsed Setpoint Values

VALUE	RESULT
0	AL T1 is used for analog output ramping function
1	AL T1 pertains to Setpoint 1
2	AL T1 pertains to Setpoint 2
3	AL T1 pertains to Setpoint 3
4	AL T1 pertains to Setpoint 4
5	AL T1 pertains to Setpoint 5

EXAMPLE: You want to assign Setpoint 2 to the AL T1 parameter. To write this information to RAM of meter #15, send the command *15P2002<CR>. The meter will respond with 15P20<CR>.

11.11 ALARM TIME ("AL TI")

This item is 2 bytes (4 characters). It specifies the pulse duration of the single setpoint set to pulsed (see 11.6 and 11.10). It uses command prefixes G, P, R, and W with the suffix 17. Values can range from 01 to 9999 where 01 corresponds to 0.01 s and 9999 corresponds to 99.99 s.

EXAMPLE: Setpoint 2 has been set to pulsed ("CNFG 3") and assigned to the AL TI parameter (Pulsed Setpoint). You want the Setpoint 2 pulse duration to be 34.12 s. To write this information to RAM of meter #15, send the command *15P170D54<CR>. The meter will respond with 15P17<CR>.

11.12 INPUT SCALE AND OFFSET ("IN.SC.OF")

Input Scale and Input Offset are 3 bytes (6 characters) each. Both use command prefixes G, P, R, and W. Input Scale uses the suffix 23. Input Offset uses the suffix 24.

Three bytes equals 24 bits. Bits 0 through 22 are assigned to the scale or offset value and decimal point as follows:

Bits 0 to 19 = the HEX value of the scale or offset

Bits 20 to 22 = decimal point location according to the following table:

Table 11.13. Input Scale and Offset ("IN.SC.OF") Bits 22,21, and 20

BIT NO.			DECIMAL NO. (POWER OF 10 MULTIPLIER)
22	21	20	
0	0	0	Not used
0	0	1	0
0	1	0	-1
0	1	1	-2
1	0	0	-3
1	0	1	-4
1	1	0	-5
1	1	1	-6

NOTE: Input Scale is always positive.

The input rate always considered "Positive".

11

Data Formats
for
Rate Meter/
Totalizers
and Batch
Meters

11

Data Formats for Rate Meter/ Totalizers and Batch Meters

Bit 23 assigns the sign of the input or offset value. In Rate and Batch Modes, 0 corresponds to a positive value and 1 corresponds to a negative value.

In Sq Rt Mode, Bit 23 acts as a factor of 100 for Input Scale. If the input scale value (excluding the decimal point) extends to more than 6 digits (1000000 or larger), the value is divided by 100 and bit 23 set to 1. In effect, the input scale value is reduced by a factor of 100 and bit 23 restores it to the original value by multiplying by an equal factor.

For example, you want your input scale to be 15.25. This equals a squared value of 232.5625. The value excluding the decimal point is larger than 1000000. Divide 2325625 by 10 to get 232563 with HEX value of 38C73. Then do the following:

1. Set Bit 23 to 1
2. The existing decimal number is 5. Add 1 to get 6. This and part 1 makes the Most Significant character as "F" value.
3. Your 3-byte HEX value = F38C73 HEX.
4. The meter interprets this as $232563 * 100 = 23256300$. Since the decimal number is 6, the true value is 232.562.

NOTES:

1. Input scale and offset applies to the input frequency, therefore all measurement data like BATCH and TOTAL values are affected according to the following formula:

$$2. \text{Result} = (\text{Input value} + \text{Input_Offset}) * \text{Input_Scale}$$

- a) According to this equation, the offset unit of measure must be the same as that for the input value, which is pulses/s or Hertz.

For example, the input frequency is 101.2 Hz and you want to calibrate it to 100 Hz, the offset value is simply -1.2 which in HEX is A0000C.

- b) In Sq Rt Mode, input scale and offset are applied on the input, before the square root is taken to give the corresponding flow rate, then rate scale and offset are applied.

3. Maximum and Minimum Values

a) Input Scale Values

For Batch and Rate Modes, input scale values can range from 0 to 1000000 with the decimal point from 1 to 6.

For Sq Rt Mode, input scale values can range from 0 to 100,000,000.

b) Input Offset Values

For Batch and Rate Modes, input offset can be ± 8000 Hz.

For Sq Rt Mode, input offset can ± 1000000 Hz.

EXAMPLE: You would like to send an input scale value of 653.84421 and an offset value of 34.3742 Hz to EEPROM of meter 15. The meter is operating in Sq Rt Mode.

a) The input scale value is 65384421 and the decimal no. is 6. The value is larger 1000000, therefore take the value as 653844. The Hex equivalent is 9FA14. The 3-byte data is E9FA14.

Send the command *15W23E9FA14<CR>. The meter will respond with 15W23<CR>.

b) The offset value is 343742 which is decimal 53EBE. The decimal number is 5 and the sign is negative, so the 3-byte data is D53EBE.

Send the command *15W24D53EBE<CR>. The meter will respond with 15W24.

11.13 BATCH DECIMAL POINT ("BAT DP") RATE DECIMAL POINT ("RTE DP") TOTAL DECIMAL POINT ("TOT DP")

These items are each 1 byte (2 characters) each use the command prefixes of G, P, R, and W. "BAT DP" and "RTE DP" use the suffix 11; TOT DP uses the suffix 14.

Table 11.14 shows the decimal point value based on the decimal no.:

11

Data Formats
for
Rate Meter/
Totalizers
and Batch
Meters

Table 11.14. Decimal Point values

DP VALUE	DECIMAL NO. (POWER OF 10 MULTIPLIER)	EQUIVALENT DECIMAL POINT POSITION
0	0	None
1	0	FFFFFF.
2	-1	FFFFF.F
3	-2	FFFF.FF
4	-3	FFF.FFF
5	-4	FF.FFFF
6	-5	F.FFFFF
7	Not used	Not used

EXAMPLE: You want BAT DP to be FFF.FFF. This corresponds to 4 Hex. To write this information to RAM of meter #15, send the command *15P1104<CR>. The meter will respond with 15P11<CR>.

**11.14 BATCH LOAD ("B LOAD")
 BATCH SCALE ("BAT SC")
 RATE OFFSET ("RTE OF")
 RATE SCALE ("RTE SC")
 TOTAL OFFSET ("TOT OF")
 TOTAL SCALE ("TOT SC")**

11

Data Formats
 for
 Rate Meter/
 Totalizers
 and Batch
 Meters

These 4 items are 3 bytes each (6 characters). All use command prefixes G, P, R, and W. Suffixes are as follows:

B LOAD and RTE OF = 12
 BAT SC and RTE SC = 13
 TOT OF = 15
 TOT SC = 16

Three bytes equals 24 bits. Bits 0 through 19 are assigned to the value in hexadecimal. Acceptable value from 0 to 999999 for positive numbers and 0 to 99999 for negative numbers.

Bits 20 - 22 are assigned to the decimal point location according to the Table 11.15:

Table 11.15. Offset and Scale Decimal Point Bits 22,21, and 20

BIT NO.			DECIMAL NO. (POWER OF 10 MULTIPLIER)
22	21	20	
0	0	0	Not used
0	0	1	0
0	1	0	-1
0	1	1	-2
1	0	0	-3
1	0	1	-4
1	1	0	-5
1	1	1	Not used
1	1	1	Not used

Bit 23 is the sign bit where 0 corresponds to a plus sign and 1 corresponds to a minus sign.

NOTES:

1. The decimal points of B LOAD, RTE OF, and TOT OF are automatically adjusted to be equal to their corresponding decimal point. For example, if the TOT DP is 3 and a value of 221.42 is entered as the TOT OF, 221.420 will be stored in memory. If the value is updated to the corresponding system decimal point and the resultant value is larger than 999999 for positive offsets or 99999 for negative offsets, FFFF will automatically be stored in the corresponding memory.
2. Scales and offsets are applied to their corresponding values according to the following formulas:

$$\text{TOTAL Reading} = (\text{Raw Total}) * (\text{TOT SC}) + \text{TOT OF}$$

$$\text{RATE Reading} = (\text{Raw Rate}) * (\text{RTE SC}) + \text{RTE OF}$$

$$\text{BATCH Count Reading} = (\text{Raw_Batch_Count}) * (\text{BAT SC}) + \text{B LOAD}$$
3. In Rate mode, Rate scale and offset has no effect on the totalizing process.
4. In Square-root Mode, rate offset is applied to the rate value before the totalizing process. Therefore Total is affected by this value.

11

Data Formats
for
Rate Meter/
Totalizers
and Batch
Meters

11

Data Formats
for
Rate Meter/
Totalizers
and Batch
Meters

EXAMPLE: You want to write a TOT OF value of 4562.33 and a TOT SC value of -324.8 to RAM of meter 15.

The TOT OF value of 4562.33 is 6F629 Hex and the decimal point value is 3. The sign is 0. Send the command *15P1536F629<CR>. The meter will respond with 15P15<CR>.

The TOT SC value of 3248 is 00CB0 Hex and the decimal point value is 2. The sign is 1. Send the command *15P16A00CB0<CR>.

11.15 SCALE OPERATOR

This item is 1 byte (2 characters). It sets the scale operator of RTE SC, TOT SC, and BAT SC to either DIVIDE or MULTIP (multiply). It uses the command prefixes of G, P, R, and W and a suffix of 21.

Table 11.16. Scale Operator Bits

BIT NO.	VALUE	FUNCTION
0	Set to 0	Not used
1	0 1	BAT SC or RTE SC = MULTIP BAT SC or RTE SC = DIVIDE
2	0 1	TOT SC = MULTIP TOT SC = DIVIDE
3 - 7	Set to 0	Not used

EXAMPLE: You want to set BAT SC to MULTIP and TOT SC to DIVIDE. To write this information to RAM of meter #15 in Batch Mode, send the command *15P2104<CR>. The meter will respond with 15P21<CR>.

11.16 SETPOINT 1 THROUGH 4 VALUES ("SP1", "SP2", "SP3", "SP4")

These items are each 3 bytes (6 characters). They use command prefixes G, P, R, and W. Setpoints 1, 2, 3, and 4 use suffixes 01, 02, 03, and 04, respectively.

The data format is identical to that of B LOAD, RTE OF, and TOT OF in Section 11.14.

11.17 SETPOINT 5 VALUE ("SP5")

This item is 3 bytes (6 characters) that corresponds to TIME value. It uses prefixes G, P, R, and W with the suffix 05.

Table 11.17. Setpoint 5

BIT NO.	VALUE	MAXIMUM VALUE ALLOWED
1	Second	59
1	Minute	59
2	Hour	99

EXAMPLE: You want to write a time of 11 (0B HEX) hours, 43 (2B HEX) minutes, and 23 (17 HEX) seconds into EEPROM of meter 15. This corresponds to a HEX value of 0B2B17. Send the command *15W050B2B17<CR> to the meter. The meter will respond with 15W05.

11.18 SET TIME ("SET TI")

This item is a special 3-byte value in Hex format. It sets the time on the display when the front-panel RESET button or the corresponding external reset is activated. It uses prefixes R and W and the suffix is 1E.

The data format is identical to that of the Setpoint 5 value in Section 11.17.

EXAMPLE: You want to set the time to 12:30:20 of meter 15. Send the command *15W1E0C1E14<CR>. The meter will respond with 15W1E<CR>.

11.19 OUTPUT SCALE

This item is 3 bytes (6 characters). It uses the prefixes G, P, R, and W with the suffix 26.

Bits 0 through 18 assign the Hex value.

Bit 19 assigns the sign where 0 corresponds to a positive value and 1 corresponds to negative value.

Bits 20 through 23 assign the decimal number as follows:

11

Data Formats
for
Rate Meter/
Totalizers
and Batch
Meters

11

Data Formats
for
Rate Meter/
Totalizers
and Batch
Meters

Table 11.18. Output Scale Bits 23, 22, 21 and 20

BIT NO.				DECIMAL NO.
23	22	21	20	(POWER OF 10 MULTIPLIER)
0	0	0	0	1
0	0	0	1	0
0	0	1	0	-1
0	0	1	1	-2
0	1	0	0	-3
0	1	0	1	-4
0	1	1	0	-5
0	1	1	1	-6
1	0	0	0	-7
1	0	0	1	-8
1	0	1	0	-9
1	0	1	1	-10
1	1	0	0	-11
1	1	0	1	-12
1	1	1	0	-13
1	1	1	1	-14

Maximum/Minimum values are ± 500000 .

EXAMPLE: You want to read the output scale value from RAM of meter 15. Send the command *15G26<CR>. The meter responds with

15G2689EDDA<CR>.

Since the meter is in ECHO mode, G26 is the echoing response, and the value to be interpreted is 89EDDA.

The last character is 8. This is the decimal number, and according to the table above it corresponds to 10^{-7} .

The next character, 9 has a most significant bit of 1, therefore the value is negative.

The rest is 1EDDA which is 126426, therefore, the value is $-126426 \times 10^{-7} = -0.0126426$.

Important Note: The true value for the output scale factor is stored in EEPROM. When the meter is operating, it combines this value with the calibration scale and offset of the Isolated Analog Output Board and stores the “modified output scale value” in RAM. Therefore, a P26 command that writes to RAM should not be used at all, or should be used very carefully. With G26 the value of the modified output scale can be read.

11.20 OUTPUT OFFSET

This item is 3 bytes (6 characters). It uses the prefixes G, P, R, and W with the suffix 27.

Bits 0 through 19 assign the value.

Bits 20 through 22 assign the decimal number according to Table 11.19.

Table 11.19 Output Offset Bits 22, 21 and 20

BIT NO.			DECIMAL NO. (POWER OF 10 MULTIPLIER)
22	21	20	
0	0	0	Not used
0	0	1	1
0	1	0	-0
0	1	1	-1
1	0	0	-2
1	0	1	-3
1	1	0	-4
1	1	1	-5

Bit 23 is the sign bit where 0 corresponds to a plus sign and 1 corresponds to a minus sign.

The maximum/minimum value is ± 999999 .

EXAMPLE: You want to read the output offset value from RAM of meter 15. Send the command *15G27<CR>. The meter responds with

11

Data Formats
for
Rate Meter/
Totalizers
and Batch
Meters

11

Data Formats
for
Rate Meter/
Totalizers
and Batch
Meters

Since the meter is in ECHO mode, G27 is the echoing response, and the value to be interpreted is D17618.

D is the decimal value and sign. This is 1101 binary, therefore the sign is negative and the power is 10^{-3} .

17618 HEX = 95768 decimal, therefore the output offset is -95.678.

Important Note: The true value for the output offset factor is stored in EEPROM. When the meter is operating, it combines this value with the calibration scale and offset of the Isolated Analog Output Board and stores the "modified output offset value" in RAM. Therefore, a P27 command that writes to RAM should not be used at all, or should be used very carefully. With G27 the value of the modified output offset can be read.

11.21 RAW MEASUREMENT VALUES; BATCH COUNT ("BATCH ", BATCH NUMBER ("BAT NO"), TOTAL, AND TIME

You can read and change values in internal registers depending upon the mode. In Batch Mode, you can read and change the values of the BATCH count, BAT NO, TOTAL, and TIME. In Rate and Sq Rt Modes, you can read and change values of TOTAL and TIME. Values can be in either RAM or EEPROM. Any time the meter is put through a hard reset, it loads raw values from EEPROM registers into the corresponding registers in RAM. (A raw value is a value that has had no scale or offset factors applied.)

All raw measurement values use prefixes C, P, R, and W. Suffixes are as follows:

BATCH count =	2A
BAT NO =	2B
TOTAL =	29
TIME =	28

Since no scale factors or offsets are applied to BAT NO and TIME, raw values are the same as final values.

1. TIME. TIME is 3 bytes where

Byte 1 (Least) =	seconds, Max 59
Byte 2 (Middle) =	minutes, Max 59
Byte 3 (Most) =	hours, Max 99

EXAMPLE: You want to assign TIME of meter #15 to 7:25:30. Send the command *15P2807191E<CR>.

2. BATCH count, BAT NO, and TOTAL. BATCH count and TOTAL are 4 bytes each, and BAT NO is 3 bytes. There is no decimal point for these items. The sign bit is the most significant bit of each item (0 for positive and 1 for negative). Therefore, max and min values for BAT NO are $\pm(7FFFFFFF)$ \pm Hex= 8,388607, and min values for Batch count and TOTAL are $\pm(7FFFFFFF)$ Hex = $\pm 2,147,483,647$.

EXAMPLE: You're in Batch Mode and want to read BATCH count, BAT NO, and TOTAL. Send the following commands:

BATCH: *15G2A<CR>. The meter responds with 15G2A003050<CR>.

BAT NO: *15G2B<CR>. The meter responds with 15G2B000038<CR>.

TOTAL: *15G29<CR>. The meter responds with 15G29000D0190<CR>.

Since the meter is in ECHO and Multipoint modes, the first 5 characters comprise the ECHO response.

The BATCH Hex value 003050 = 12368 in decimal.

The BAT NO Hex value 000038 = 56 in decimal.

The TOTAL Hex value 000D0190 = 852368 in decimal.

11

Data Formats
for
Rate Meter/
Totalizers
and Batch
Meters

11

Data Formats
for
Rate Meter/
Totalizers
and Batch
Meters

11.22 BAUD RATE ("BAUD")

This item is 1 byte (2 characters). It specifies the communication rate over the bus. It uses prefixes R and W and the suffix 19. Table 11.20 shows data values and their corresponding baud rates.

Table 11.20. Baud Rate ("BAUD") Data Values

DATA VALUE	BAUD RATE
0	300
1	600
2	1200
3	2400
4	4800
5	9600
6	19200

EXAMPLE: You want to set the baud rate of meter #15 to 9600. Send the command *15W1905<CR>. The meter responds with 15W19<CR>. You should then reset the meter with *15Z05<CR>. The meter will respond with 15Z05<CR>.

11.23 SERIAL COMMUNICATIONS CONFIGURATION ("SER.CNF")

This item is 1 byte (2 characters). It uses prefixes R and W with the suffix 1A according to Table 11.21.

Table 11.21. Serial Configuration ("SER.CNF") Bits

BIT NO.	VALUE	FUNCTION
0	0	1 Stop bit
	1	2 Stop bits
1 - 2	0	No parity
	1	Odd parity
	2	Even parity
	3	Not used
3	0	Chunk transmission*
	1	Single, long transmission**
4 - 7	1	Not used

* Chunk transmission means that the meter transmits data while it is performing measurements.

** A single, long transmission means that all of the data is transmitted at the same time. The meter does not do other tasks until transmission is complete. This mode is useful and fast only with higher baud rates such as 9600 and 19200. It is not recommended for lower rates.

11.24 DATA FORMAT ("DAT FT")

This item is 1 byte (2 characters). Different bits of this byte specify the data to be transmitted in response to Continuous Communications (see Section 7), V01 and external print commands (see Section 8). This item uses prefixes G, P, R, and W with the suffix 1B.

Table 11.22 shows bit assignments.

Table 11.22. Data Format ("DAT FT") Bits

BIT NO.	VALUE	FUNCTION
0	0	Alarm status character excluded from transmission
	1	Alarm status character included in transmission
1	0	BATCH (or RATE) value excluded from transmission
	1	BATCH (or RATE) value included in transmission
2	0	BAT NO (or AVG RT) excluded from transmission
	1	BAT NO (or AVG RT) included in transmission
3	0	TOTAL value excluded from transmission
	1	TOTAL value included in transmission
4	0	TIME excluded from transmission
	1	TIME included in transmission
5	0	No unit of measure for BATCH (or RATE)
	1	Unit of measure transmitted for BATCH (or RATE)
6	0	No unit of measure for BAT NO (or AVG RT)
	1	Unit of measure transmitted for BAT NO (or AVG RT)
7	0	No unit of measure for TOTAL value
	1	Unit of measure transmitted for TOTAL value

11

Data Formats
for
Rate Meter/
Totalizers
and Batch
Meters

11

Data Formats
for
Rate Meter/
Totalizers
and Batch
Meters

EXAMPLE: You are in Rate Mode using continuous transmission. You want to configure RAM such that the transmission includes the alarm status character, the RATE value and unit of measure, and the TOTAL value. These settings correspond to binary 00101011 = 2B Hex. Send the command *15P1B2B<CR>. The meter will respond with 151B<CR>.

11.25 COMMUNICATION BUS FORMAT ("BUS FT")

This item is 1 byte (2 characters). It specifies bus information such as protocols. It uses prefixes G, P, R, and W with the suffix 1C.

Table 11.23 show bit assignments.

Table 11.23. Bus Format ("BUS FT") Bits

BIT NO.	VALUE	FUNCTION
0	0	No check sum byte
	1	Check sum byte required for data
1	0	No line feed for transmitted value
	1	Line feed after each <CR>
2	0	No ECHO response
	1	ECHO response
3	0	Communication Mode is Point-to-Point
	1	Communication Mode is Multipoint
4	0	Point-to-Point is Continuous
	1	Multipoint or Point-to-Point is Command Mode
5	0	Continuous Mode uses Message Hand shake
	1	Continuous Mode uses Character Hand shake
6	0	RS-485 Board not Installed
	1	RS-485 Board Installed
7	0	Space inserted between multiple items
	1	Carriage Return <CR> inserted between multiple items

EXAMPLE: You are in Batch Mode. You want to configure RAM such that the mode is Point-to-Point Continuous with a message hand shake; you do not want to use a check sum, line feed, and

have no RS-232 or RS-485 board installed. You want to print each item on a new line (meaning you want to use the <CR> as the item spacer). The bits values for these choices correspond to binary 1000100 = 80 Hex. Send the command *15P1C80<CR>. The meter will respond with 151C<CR>.

11.26 RS-485 METER ADDRESS ("ADDRESS")

This item is 1 byte (2 characters). It specifies the address of a meter where more than one meter is on the transmission bus. It uses prefixes G, P, R, and W with the suffix 1D. Data values can be 1 to 199 decimal = 1 to C7 Hex.

EXAMPLE: You want to change the address of meter 15 to 24 in RAM. Send the command *15P1D24<CR>. The meter will respond with 15P1D<CR>. The meter address is now 24 and commands must begin with *24....

11.27 TIME BETWEEN EACH TRANSMISSION ("SER TI")

This item is a 2-byte Hex value. It specifies the time between transmissions for Continuous Mode only. It uses prefixes R, P, R, and W with the prefix 1E.

Table 11.24 shows data values.

Table 11.24. Serial Time ("SER TI") Values

VALUE	FUNCTION
0	Transmit at each reading cycle
1 to 59999 (decimal)	Transmit using this interval (in seconds) between transmissions

EXAMPLE: You want to configure RAM such that you get a print out of certain items every hour. This corresponds to an interval of 3600 s = E10 Hex. Send the command *15P1E0E10<CR>. The meter will respond with 151E<CR>.

11.28 RECOGNITION CHARACTER

This item is a 1-byte Hex value. The recognition character is the first transmitted character in a command string. It ensures that the corresponding command is read by the correct meter. It uses the prefixes G, P, R and W with the suffix 24.

11

Data Formats
for
Rate Meter/
Totalizers
and Batch
Meters

11

Data Formats
for
Rate Meter/
Totalizers
and Batch
Meters

Characters with an equivalent Hex value of 0 to 20, and 80 to FF are not allowed. Also, the caret (^), the capital A, and the capital E are not allowed.

EXAMPLE: You want to change the recognition character of meter #15 from the asterisk (*) to the point symbol (#). The hex value of # is 23. Send the command *15P2423<CR>. The meter will respond with 15P24<CR>. The recognition character is now # and the meter will not respond to any other character.

11.29 UNITS OF MEASURE

There are two units of measure items. Each is a 3- byte Hex value using the prefixes R and W. Unit 1 uses suffix 2C and Unit 2 uses the suffix 2D.

Unit 1 pertains to BATCH, BAT NO, RATE, or AVG RT values. Unit 2 pertains to TOTAL values.

Units 1 and/or 2 are transmitted after the corresponding value if they have been enabled by a DAT FT bit.

EXAMPLE: You are in Rate Mode and want Unit 1 and Unit 2 to be GPM and GAL, respectively. Looking at the ASCII table in Section 4-5, you see that GPM corresponds to a Hex value of 47504D; GAL corresponds to a Hex value of 47414C. To configure GPM units of measure, send the command *15W2C47504D<CR>. The meter will respond with 15W2C<CR>. To configure GAL units of measure, send the command *15W2D47414C<CR>. The meter will respond with 15W2D<CR>.

11.30 TX/RX TURNAROUND DELAY (SERIAL DELAY)

This item is 1 byte (2 characters). It controls the delay time between the end of one transmission from the host to the start of response from the meter. It uses command prefixes G, P, R and W with the suffix 25.

Table 11.25 shows the bit assignments.

Table 11.25. Serial Delay ("SER.DLY") Bits

BIT NO.	VALUE	MILLISECONDS OF TURNAROUND DELAY
0-1	0	0
	1	10
	2	30
	3	200
2-7	Set to 0	Not used

11.31 CALIBRATION ITEMS

a) Analog Output. These items are each 2-byte Hex values (4 characters), that are on the back of the isolated analog output board:

- 1) CAL VZ (Calibrate Voltage Zero)
- 2) CAL VS (Calibrate Voltage Span)
- 3) CALmAZ (Calibrate milliAmp Zero)
- 4) CALmAS (Calibrate milliAmp Span)

All items use command prefixes R and W, and suffixes are as follows:

CAL VZ = 2F
 CAL VS = 30
 CALmAZ = 31
 CALmAS = 32

Legal values for each item can be from 0 to 59999 decimal or from 0 to EA5F HEX.

b) Internal Oscillator Frequency. This is a 1-byte hex value (2 characters) that uses the command prefixes R and W with the suffix 2E. Units of the value are Hz. This value is added to or subtracted from the original oscillator frequency which is 11.059 MHz.

Bits 0 to 6 (the least 7 bits) are assigned to the value.

Bit 7 (the most significant bit) is the sign bit where 0 is a positive value and 1 is a negative value.

11

Data Formats
 for
 Rate Meter/
 Totalizers
 and Batch
 Meters

11

Data Formats
for
Rate Meter/
Totalizers
and Batch
Meters

The oscillator frequency can be calibrated to ± 127 Hz.

EXAMPLE: You want to subtract 15 Hz from the oscillator frequency. Send the command *15W2E8F<CR>. The meter will respond with 15W2E<CR>. Reset the meter with the command *15Z05<CR>.

11.32 BLOCK READ OR WRITE

A Block consists of more than one item. The data pattern is the union of all individual byte pattern items included in that block and its order is exactly as described in corresponding tables below:

1. Block transmit command structure for "P" or "W":

*[nn][ccc]<data>[hh]<CR>

2. Block receive structure for "G" or "R":

*[nn][ccc]<data>[hh]<CR>[LF]

Note 1: Byte No. 1 is the MS byte in <data> block.

Note 2: MS byte of each item is the first to transmitted or received.

Note 3: If the meter is in "No Echo Mode", [nn][ccc] will be omitted from receive data format.

Note 4: One byte is equal to two ASCII characters.

Note 5: One block length might be different for each different mode or for different command prefixes.

Table 11.26 of Block Command prefixes and suffixes is for Batch Controller, Rate Meter and Square Root Meters.

Table 11.26 Description of Block Commands

BLOCK	COMMAND PREFIX	COMMAND SUFFIX (HEX)
A	G, P, R, W	40
B	G, P, R, W	41
C	G, P, R, W	42
D	R, W	43
E	R, W	44

11.32.1 BLOCK A (FOR G, P, R, W COMMANDS)

This block has different data length depending on meter's mode. It consists of eighteen (18) items and thirty eight (38) bytes (76 ASCII characters) in the Batch mode as in Table 11.27; and nineteen (19) items and thirty nine (39) bytes (78 ASCII characters) in the rate or square root modes as in Table 11.28.

Table 11.27 Block A For Batch Mode

ITEM (HEX) SUFFIX	DESCRIPTION	BYTE NO. & ORDER
16	Total scale	1, 2, 3
15	Total offset	4, 5, 6
14	Total decimal point	7
13	Batch scale	8, 9, 10
12	Batch load	11, 12, 13
11	Batch decimal point	14
0D	Configuration 4	15
0C	Configuration 3	16, 17, 18
0B	Configuration 2	19
0A	Configuration 1	20
08	Lockout 3	21
07	Lockout 2	22
06	Lockout 1	23
05	Setpoint 5 value	24, 25, 26
04	Setpoint 4 value	27, 28, 29
03	Setpoint 3 value	30, 31, 32
02	Setpoint 2 value	33, 34, 35
01	Setpoint 1 value	36, 37, 38

11

Data Formats
for
Rate Meter/
Totalizers
and Batch
Meters

Table 11.28. Block A For Rate and Square-root Modes

ITEM (HEX) SUFFIX	DESCRIPTION	BYTE NO. & ORDER
16	Total scale	1, 2, 3
15	Total offset	4, 5, 6
14	Total decimal point	7
13	Rate scale	8, 9, 10
12	Rate offset	11, 12, 13
11	Rate decimal point	14
0E	Average configuration	15
0D	Configuration 4	16
0C	Configuration 3	17, 18, 19
0B	Configuration 2	20
0A	Configuration 1	21
08	Lockout 3	22
07	Lockout 2	23
06	Lockout 1	24
05	Setpoint 5 value	25, 26, 27
04	Setpoint 4 value	28, 29, 30
03	Setpoint 3 value	31, 32, 33
02	Setpoint 2 value	34, 35, 36
01	Setpoint 1 value	37, 38, 39

11

Data Formats
for
Rate Meter/
Totalizers
and Batch
Meters

1.32.2 BLOCK B FOR BATCH METER AND SQUARE-ROOT METER

Block B has different data length depending on the Prefix Command.

a) Command Prefix: "C" or "P". It consists 11 items, 17 bytes (34 ASCII characters) as in Table 11.29.

Table 11.29. Block B For "G" or "P" Commands For Batch or Square-root Modes

ITEM (HEX) SUFFIX	DESCRIPTION	BYTE NO. & ORDER
25	Serial delay	1
24	Recognition character	2
23	Input offset	3, 4, 5
22	Input scale	6, 7, 8
21	Scale operator	9
20	Pulsed alarm number	10
1E	Serial time	11, 12
1D	Serial address	13
1C	Bus format	14
1B	Data format	15
17	Pulsed alarm time	16, 17

b) Command Prefix: "R" or "W". It consists of 15 items, 25 bytes (50 ASCII characters) as shown in Table 11.30:

Table 11.30. Block B For "R" or "W" Commands For Batch Meter or Square-root Modes

ITEM (HEX) SUFFIX	DESCRIPTION	BYTE NO. & ORDER
27	Output offset	1, 2, 3
26	Output scale	4, 5, 6
25	Serial delay	7
24	Recognition character	8
23	Input offset	9, 10, 11
22	Input scale	12, 13, 14
21	Scale operator	15
20	Pulsed alarm number	16
1E	Serial time	17, 18
1D	Serial address	19
1C	Bus format	20
1B	Data format	21
1A	Serial configuration	22
19	Baud rate	23
17	Pulsed alarm time	24, 25

11

Data Formats for Rate Meter/Totalizers and Batch Meters

11

Data Formats
for
Rate Meter/
Totalizers
and Batch
Meters

11.32.3 BLOCK B FOR RATE METER

Block B has different data length depending on the Prefix Command.

a) Command Prefix: "G" or "P". It consists of 12 items, 18 bytes (36 ASCII characters) as shown in Table 11.31:

Table 11.31. Block B For "G" or "P" Commands For the Rate Mode

ITEM (HEX) SUFFIX	DESCRIPTION	BYTE NO. & ORDER
25	Serial delay	1
24	Recognition character	2
23	Input offset	3, 4, 5
22	Input scale	6, 7, 8
21	Scale operator	9
20	Pulsed alarm number	10
1E	Serial time	11, 12
1D	Serial address	13
1C	Bus format	14
1B	Data format	15
18	Gate time	16
17	Pulsed alarm time	17,18

b) Command Prefix: "R" or "W". It consists of 16 items, 26 bytes (52 ASCII characters) as shown in Table 11.32:

Table 11.32. Block B For "R" or "W" Commands For the Rate Mode

ITEM (HEX) SUFFIX	DESCRIPTION	BYTE NO. & ORDER
27	Output offset	1, 2, 3
26	Output scale	4, 5, 6
25	Serial delay	7
24	Recognition character	8
23	Input offset	9, 10, 11
22	Input scale	12, 13, 14
21	Scale operator	15
20	Pulsed alarm number	16
1E	Serial time	17, 18
1D	Serial address	19
1C	Bus format	20
1B	Data format	21
1A	Serial configuration	22
19	Baud rate	23
18	Gate time	24
17	Pulsed alarm time	25, 26

11.32.4 BLOCK C FOR BATCH MODE ONLY

This block for command prefixes P, G, R, W consists of 3 items, 11 bytes (22 ASCII characters) as shown in Table 11.33.

Table 11.33. Block C For "P, G, R, W" Prefix Commands for the Batch Mode

ITEM (HEX) SUFFIX	DESCRIPTION	BYTE NO. & ORDER
2B	Number of batches (raw)	1, 2, 3
2A	Batch value (raw)	4, 5, 6, 7
29	Total (raw)	8, 9, 10, 11

11.32.5 BLOCK D FOR BATCH, SQUARE-ROOT AND RATE MODES

a) This block is for the "R" and "W" prefix commands and consists of 2 items, 6 bytes (12 ASCII characters) as shown in Table 11.34.

Table 11.34. Block D For "R" and "W" Prefix Commands for the Batch, Square-root and Rate Modes.

ITEM (HEX) SUFFIX	DESCRIPTION	BYTE NO. & ORDER
2D	Unit of measure number 2	1, 2, 3
2E	Unit of measure number 1	4, 5, 6

11

Data Formats
for
Rate Meter/
Totalizers
and Batch
Meters

11.32.6 BLOCK E FOR BATCH, SQUARE-ROOT AND RATE MODES

This block is for the "P" and "W" prefix commands and consists of 5 items, 9 bytes (18 ASCII characters) as shown in Table 11.34.

Table 11.34. Block E For "P and W" Prefix Commands For the Batch meter, Square-root and Rate Modes

ITEM (HEX) SUFFIX	DESCRIPTION	BYTE NO. & ORDER
32	Calibration current span	1, 2
31	Calibration current zero	3, 4
30	Calibration volt span	5, 6
2F	Calibration volt zero	7, 8
2E	Calibration Oscillator Frequency	9

11.32.7 EXAMPLE

EXAMPLE: Assume you want to send raw values for the batch meter #15 hex as below:

Batch value: 785,424 = BFC10 Hex
of Batches: 754 = 2F2 Hex
Total value: 592,209,696 = 234C6720 Hex

Computer sends:
"*P420002F2000BCF10234C6720<CR>"

If you are in echo mode, you will receive:
"P42<CR>"

11

Data Formats
for
Rate Meter/
Totalizers
and Batch
Meters

Index

A

^AE:	
Command	8-2
Response Format	8-21
⁽⁴⁸⁾	8-5
5 Hz	11-9
10 Hz	11-9
50 Hz	10-10, 11-6
60 Hz	10-10, 11-6
100 Hz	11-9
300 Hz	11-9
ABC Filter	10-13, 11-11
Active Above/Below:	
SP1, SP2	10-14, 11-6
SP3, SP4	10-15, 11-6
SP5	11-6
AL1, AL2	10-15
Address (ADDRES)	10-10, 10-20, 11-27
Alarm:	
Configuration (ALCNF)	10-15
Dead Band (ALDB)	10-18
Delay (ALRDG)	10-17
Function (ALFNC)	10-16
Latched/Unlatched	10-16, 11-8, 11-9
Mode	7-2
Reset	10-16
Status	8-18, 8-19, 10-21
Time (ALTI)	11-13
Analog Out	10-19, 11-7
ARX	2-1
ASCII	4-3
ATX	2-1
Average Configuration (AVG.CNF)	11-11

B

Band Deviation	10-16
Batch:	
Decimal Point (BAT DP)	11-15
Load (B LOAD)	11-16
Mode	11-3
Scale (BAT SC)	11-16

I

Index

Baud Rate (BAUD)	5-1, 10-20, 11-24
BCD	10-19, 11-7
Bipolar	10-10
Block:	8-7
A	10-28, 11-31
B	10-28, 11-31, 11-34
C	10-29, 11-35
D	11-35
E	11-36
Read, Write	10-27, 11-32
Bracket	8-1
Bridge Input	10-4
Brightness	10-6, 11-5
BRX	2-1
BTX	2-1
Bus Format (BUS FT)	10-22, 11-25
Bus Response	9-1

C

Calibration Items	11-29
CALmAS	11-29
CALmAZ	11-29
CAL VS	11-29
CAL VZ	11-29
"CCC"	8-5
Character:	
Handshake	7-2, 10-22, 11-26
Recognition	4-6, 10-21, 11-27
Waveform	6-1
Check Sum	8-5, 10-22, 11-26
Chunk Transmission	11-24, 11-25
Class	7-1
Cold Junction	10-11
Command:	
Block	10-28, 11-30
Format	8-4
Mode	7-2, 10-22, 11-26
Single	8-5, 8-8
Structure	8-1
Configuration:	
1 (CNFG1)	11-15
2 (CNFG2)	11-6
3 (CNFG3)	11-7
4 (CNFG4)	11-10
Alarm	10-15
Average	11-11

I

Index

Filter	10-13
Input	10-10
Output	10-18
Reading	10-6
Serial Communication	10-19, 11-24
Continuous Mode	7-1, 10-22, 11-26
Count By (CNT BY)	10-12
Current Input	10-4
Cutoff	11-9

D

Data:	8-1
Format (DATFT)	10-1, 10-21, 11-1, 11-25
Length	8-14
DCE	4-1
Dead Band	10-18
Decimal Point (DEC PT)	10-12, 11-15
Delay:	
Alarm	10-16
Setpoint	11-6
Turnaround	10-25, 11-28
Deskrop	10-19, 11-20
Deviation	10-16
DIN	10-4
Diskerte	3-1
Display:	
Flashing	10-18
Hold	11-10
Mode	11-3
Divide	11-18
DTE	4-1

E

Echo Response	10-22, 11-26
EEPROM	4-7
Error:	
Message	8-15
Response	8-15
Examples	8-22
External:	
Print	8-20, 10-23, 11-10
Reset	11-10

I

Index

F

Factor	10-7
Fast:	
Read Rate	10-10
Response	11-9
Filter:	
ABC	10-13, 11-14
Configuration (FIL.CNF)	10-13
Normal	10-13, 11-14
Time (FIL.TI)	10-13
Flashing	10-18
Format	8-4
Frequency:	10-10
Cutoff	11-9
Function, Alarm	10-16
Full Duplex	4-2

G

"GATE T"	11-12
GET Command	8-3
GND	2-1

H

Half Duplex	4-2
Handshake	7-1, 7-2, 10-22, 11-26
HEX ASCII	4-4
"hh"	8-5
High Deviation	10-16
Host	4-1
Hysteresis	10-7, 11-8

I

Input:	
Class	10-4
Configuration (INCNF)	10-10
Offset	10-9, 11-13
Scale	10-7, 11-13
Type (INPUT)	10-4
"IN.SC.OF"	10-11, 11-13

L

Latched Alarm	10-16, 11-8, 11-9
Levels	4-6
Leading Zero	10-6
LED 1, 2	10-4

I

Index

Line Feed (LF)	10-22, 11-26
Linear	10-4
Load	11-16
Lockout Bytes	10-11, 11-1
Lockout 1 Configuration (L1CNF)	10-2, 11-2
Lockout 2 Configuration (L2CNF)	10-2, 11-2
Lockout 3 Configuration (L3CNF)	10-3, 11-3
Lockout 4 Configuration (L4CNF)	10-3
Low Deviation	10-16

M

Mark Bit	6-1
Message Handshake	7-1, 10-22, 11-26
Mode (MODE)	11-2
Modified:	
Output Scale	10-7, 11-21
Output Offset	10-10, 11-22
Multipoint:	
Definition	4-1
Bit	10-22, 11-26
Class	7-2
Command Mode	7-2
Alarm Mode	7-2
"MULTIP"	11-18

N

NIST	10-4
"nn"	8-5
No Deviation	10-16
No Error	8-12
Non Data	8-1
Normal Filter	10-13, 11-11

O

Offset:	
Input	10-9, 11-13
Reading	10-9
Modified	10-10, 11-22
Output	10-9
Rate	11-16
Batch	11-16
Total	11-16
Ohm Input	10-4
Operation	7-11
Operator, Scale	11-18

I

Index

Output:	
Configuration (OUT.CNF).....	10-18
Offset	10-9, 11-21
Scale	10-7, 11-19

P

Panel	10-19
Parity	6-1, 10-20, 11-24
Parallel BCD	10-19
Peak Status	8-20, 10-21
Point to Point:	
Bit	10-22, 11-26
Class	7-1
Command Mode	7-2, 10-22, 11-26
Continuous Mode	7-1, 10-22, 11-26
Definition.....	4-1
Potentiometer	10-4
Prefix	8-3
Printer:	
Desktop.....	10-19, 11-10
Panel	10-19, 11-10
Process Deviation	10-16
Proportional, Time	11-7
Pulsed.....	11-8, 11-12
Pur Command.....	8-3

R

RAM	4-6
Ramp.....	11-7
Ratio	10-11
Rate:	
Decimal Point (RTE DP)	11-15
Mode	11-3
Offset (RTE OF)	11-16
Scale (RTE SC)	11-16
Raw Measurement Data	11-22
"RD.SC. OF"	10-6
Read:	
Command	8-3
Rate	10-10
Reading:	
Configuration (RDG.CNF)	10-6
Offset (RDG OF)	10-7
Scale (RDG SC)	10-9
Recognition Character	4-6, 10-21, 11-27

I

Index

Remote:	
Display	7-3
Meter	7-4
Reset:	
Commands	8-6, 8-8, 8-9
External	11-10
Hard	10-6
Tare	8-6
Resistance Temperature Detector (RTD)	10-4
Response Structure	8-12
Response Time:	
Alarm Mode	9-5
Command Mode	9-1
Continuous Mode	9-3
External Print	9-6
RJ11	2-13, 2-4
RJ12	2-4, 2-5
Round Off	10-12
RS232:	
Board	2-2, 10-23
Definition	4-2
Hardware	2-1
Installation	2-2
RS422, Definition	4-2
RS485:	
Address	10-20, 11-27
Board	2-5, 10-23, 11-26
Definition	4-3
Hardware	2-5
Installation	2-6
RTS	4-2, 10-22, 11-26
RX	2-1
S	
Sample	10-7
Scale:	
Batch	11-16
Input	10-7, 11-3
Modified	10-7, 11-22
Operator	11-18
Output	10-7, 11-19
Rate	11-16
Reading	10-7
Total	11-16

I

Index

Serial Communication:	
Configuration (SER.CNF)	10-19, 11-24
Delay	10-25, 11-28
Transmission Count Delay (SER.CNT)	10-23
Transmission Time Delay (SER.TI)	11-19
Setpoint:	
Dead Band (SP.DB)	10-18
Configuration 1,2 (SP.CNF)	10-14
Configuration 3,4 (AL.CNF)	10-15
1,2,3,4 Values (SP1, SP2, SP3, SP4)	10-26, 11-17
5 Value (SP.5)	11-19
Set Time (SET.TI)	11-19
Simplex	4-11
Single:	
Command Table	8-5, 8-8
Transmission	11-24
Slide Wire	10-4
Slow Read Rate	10-10
Space Bit	6-1
Status Character	8-18
Start Bit	6-1
Stop Bit	6-1, 10-20, 11-24
Stop Command	11-10
Suffix	8-5
T	
Tare Command	8-6
Table:	
Alarm Status Character	8-18, 8-19
ASCII	4-5
Error Messages	8-15
Peak/Valley Status Character	8-20
Prefix Letters	8-3
Suffix Values	8-6, 8-7, 8-8, 8-9, 8-10
Thermocouple (TC)	10-4
Total:	
Decimal Point	11-15
Offset (TOT.OF)	11-16
Scale (TOT.SC)	11-16
Transistor:	
Out 1, 2, 3, 4	10-14, 11-5
Out 5	11-5
Transmitter	10-11
Turnaround Delay (SER.DLY)	10-25, 11-28
TX	2-1

I

Index

U

Unlatched Alarm	10-16, 11-8, 11-9
Unit of Measure	10-24, 11-28
Unipolar	10-10

V

Value, Definition	8-1
Voltage Levels	4-6
Valley Status	8-20, 10-21
Volt Input	10-4
V01:	
Command	8-20
Response	8-20

W

Waveform	6-1
Write Command	8-3
Watchdog	9-7
Wait Time	11-9

X

X-On	4-5
X-Off	4-5

Warranty/Disclaimer

NEWPORT Electronics, Inc. warrants this unit to be free of defects in materials and workmanship for a period of one (1) year from the date of purchase. In addition to NEWPORT's standard warranty period, NEWPORT Electronics will extend the warranty period for one (1) additional year if the warranty card enclosed with each instrument is returned to NEWPORT.

If the unit should malfunction, it must be returned to the factory for evaluation. NEWPORT's Customer Service Department will issue an Authorized Return (AR) number immediately upon phone or written request. Upon examination by NEWPORT, if the unit is found to be defective it will be repaired or replaced at no charge. NEWPORT's WARRANTY does not apply to defects resulting from any action of the purchaser, including but not limited to mishandling, improper interfacing, operation outside of design limits, improper repair, or unauthorized modification. This WARRANTY is VOID if the unit shows evidence of having been tampered with or shows evidence of being damaged as a result of excessive corrosion; or current, heat, moisture or vibration; improper specification; misapplication; misuse or other operating conditions outside of NEWPORT's control. Components which wear are not warranted, including but not limited to contact points, fuses, and triacs.

NEWPORT is pleased to offer suggestions on the use of its various products. However, NEWPORT neither assumes responsibility for any omissions or errors nor assumes liability for any damages that result from the use of its products in accordance with information provided by NEWPORT, either verbal or written. NEWPORT warrants only that the parts manufactured by it will be as specified and free of defects. NEWPORT MAKES NO OTHER WARRANTIES OR REPRESENTATIONS OF ANY KIND WHATSOEVER, EXPRESSED OR IMPLIED, EXCEPT THAT OF TITLE, AND ALL IMPLIED WARRANTIES INCLUDING ANY WARRANTY OF MERCHANTABILITY AND FITNESS FOR A PARTICULAR PURPOSE ARE HEREBY DISCLAIMED. LIMITATION OF LIABILITY: The remedies of purchaser set forth herein are exclusive and the total liability of NEWPORT with respect to this order, whether based on contract, warranty, negligence, indemnification, strict liability or otherwise, shall not exceed the purchase price of the component upon which liability is based. In no event shall NEWPORT be liable for consequential, incidental or special damages.

CONDITIONS: Equipment sold by NEWPORT is not intended to be used, nor shall it be used: (1) as a "Basic Component" under 10 CFR 21 (NRC), used in or with any nuclear installation or activity; or (2) in medical applications or used on humans. Should any Product(s) be used in or with any nuclear installation or activity, medical application, or used on humans, or misused in any way, NEWPORT assumes no responsibility as set forth in our basic WARRANTY / DISCLAIMER language, and additionally purchaser will indemnify NEWPORT and hold NEWPORT harmless from any liability or damage whatsoever arising out of the use of the Product(s) in such a manner.

Return Requests/Inquiries

Direct all warranty and repair requests/inquiries to the NEWPORT Customer Service Department. **BEFORE RETURNING ANY PRODUCT(S) TO NEWPORT, PURCHASER MUST OBTAIN AN AUTHORIZED RETURN (AR) NUMBER FROM NEWPORT'S CUSTOMER SERVICE DEPARTMENT (IN ORDER TO AVOID PROCESSING DELAYS).** The assigned AR number should then be marked on the outside of the return package and on any correspondence.

The purchaser is responsible for shipping charges, freight, insurance and proper packaging to prevent breakage in transit.

FOR **WARRANTY** RETURNS, please have the following information available BEFORE contacting NEWPORT:

1. P.O. number under which the product was PURCHASED,
2. Model and serial number of the product under warranty, and
3. Repair instructions and/or specific problems relative to the product.

FOR **NON-WARRANTY** REPAIRS, consult NEWPORT for current repair charges. Have the following information available BEFORE contacting NEWPORT:

1. P.O. number to cover the COST of the repair,
2. Model and serial number of product, and
3. Repair instructions and/or specific problems relative to the product.

NEWPORT's policy is to make running changes, not model changes, whenever an improvement is possible. This affords our customers the latest in technology and engineering. NEWPORT is a registered trademark of NEWPORT ELECTRONICS, INC.

© Copyright 2002 NEWPORT ELECTRONICS, INC. All rights reserved. This document may not be copied, photocopied, reproduced, translated, or reduced to any electronic medium or machine-readable form, in whole or in part, without prior written consent of NEWPORT ELECTRONICS, INC.

For immediate technical or application assistance please call:

1-800-6397678®
1-800-NEWPORT

Newport Electronics, Inc.
2229 South Yale Street • Santa Ana, CA • 92704 • U.S.A.
TEL: (714) 540-4914 • FAX: (714) 546-3022
Toll Free: 1-800-639-7678 • <http://www.newportUS.com> • e-mail:info@newportUS.com
ISO 9001 Certified

Newport Technologies, Inc.
976 Bergar • Laval (Quebec) • H7L 5A1 • Canada
TEL: (514) 335-3183 • FAX: (514) 856-6886
Toll Free: 1-800-639-7678 • <http://www.newport.ca> • e-mail:sales@newport.ca

Newport Electronics, Ltd.
One Omega Drive • River Bend Technology Centre
Northbank, Irlam • Manchester M44 5BD • United Kingdom
Tel: +44 161 777 6611 • FAX: +44 161 777 6622
Toll Free: 0800 488 488 • <http://www.newportuk.co.uk> • e-mail:sales@newportuk.co.uk

Newport Electronics B.V.
Postbus 8034 • 1180 LA Amstelveen • The Netherlands
TEL: +31 20 3472121 • FAX: +31 20 6434643
Toll Free: 0800 0993344 • <http://www.newport.nl> • e-mail: sales@newport.nl

Newport Electronics spol s.r.o.
Rudé armády 1868, 733 01 Karviná 8 • Czech Republic
TEL: +420 69 6311899 • FAX: +420 69 6311114
Toll Free: 0800-1-66342 • <http://www.newport.cz> • e-mail: sales@newport.cz

Newport Electronics GmbH
Daimlerstrasse 26 • D-75392 Deckenpfronn • Germany
TEL: 49 7056 9398-0 • FAX: 49 7056 9398-29
Toll Free: 0800 / 6397678 • <http://www.newport.de> • e-mail: sales@newport.de

Newport Electronique S.A.R.L.
9, rue Denis Papin • 78190 Trappes • France
TEL: +33 130 621 400 • FAX: +33 130 699 120
Toll Free: 0800-4-06342 • <http://www.newport.fr> • e-mail: sales@newport.fr

Mexico and Latin America
TEL: 001-800-826-6342 • FAX: 001 (203) 359-7807
En Español: 001 (203) 359-7803

NEWPORTnetSM On-Line Service www.newportUS.com	Internet e-mail info@newportUS.com
--	--